



INSTALLATION INSTRUCTIONS

Accessory AUXILIARY JACK	Application CIVIC 4 DOOR (LX)	Publications No. All 29216
		Issue Date SEP 2005

PARTS LIST

Auxiliary Jack
P/N 08A60-SNA-100

Auxiliary jack

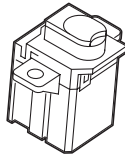

Auxiliary jack trim

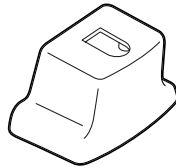

Auxiliary jack harness



6 Self-tapping screws



4 Wire ties

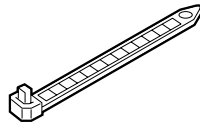

2 Cushion tapes

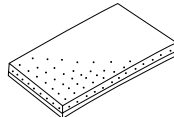

TOOL AND SUPPLIES REQUIRED

- Phillips screwdriver
- Pushpin
- Eye protection (face shield, safety goggles, etc.)
- Drill
- 3 mm and 5 mm Drill bits
- 30 mm Hole saw

INSTALLATION

Customer Information: The information in this installation instruction is intended for use only by skilled technicians who have the proper tools, equipment, and training to correctly and safely add equipment to your vehicle. These procedures should not be attempted by "do-it-yourselfers".

1. Make sure you have the anti-theft code for the radio, then write down the frequencies for the preset buttons.
2. Disconnect the negative cable from the battery.

3. Remove the center console cover:

• **M/T Vehicle**

- Pull down on the shift boot and remove the shift knob by turning it counterclockwise.

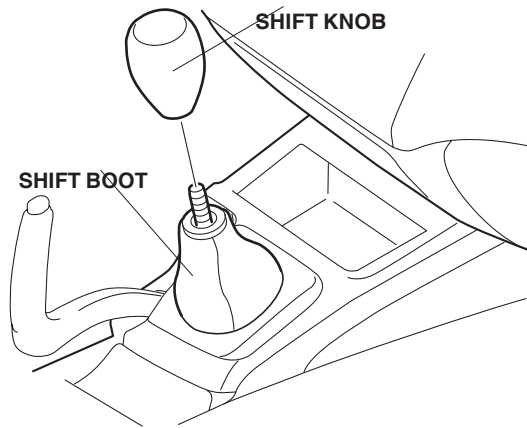

- Remove the center console cover by removing the five clips fastening the center console cover.

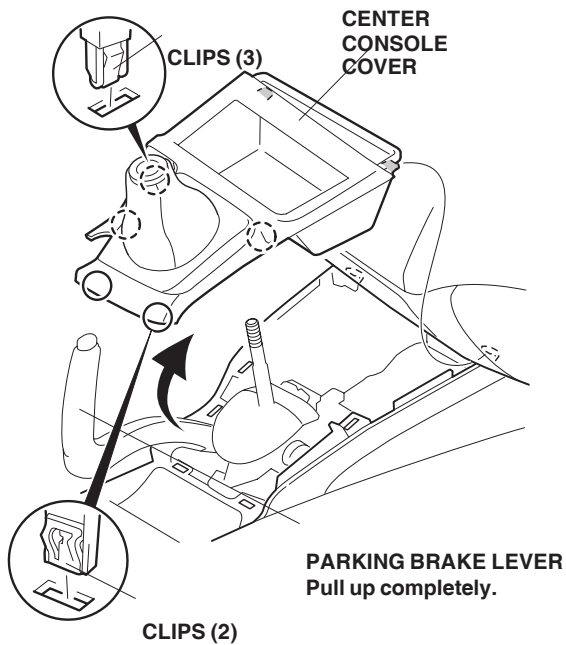

A/T Vehicle

- Remove the center console cover (five clips).

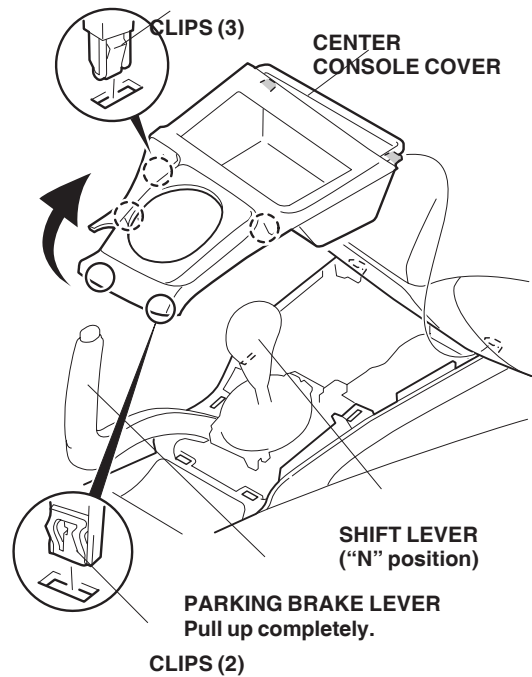

Installing the Auxiliary Jack

- 4. Measure and mark on the back of the center console cover in five places. Using a push pin, mark the back of the center console cover as shown.

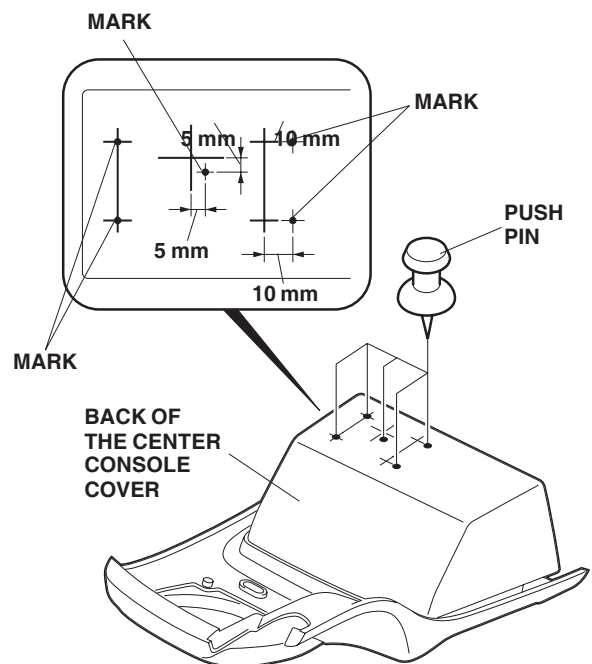

5. While wearing eye protection, drill four 5 mm holes and one 30 mm hole through the marks you just made.

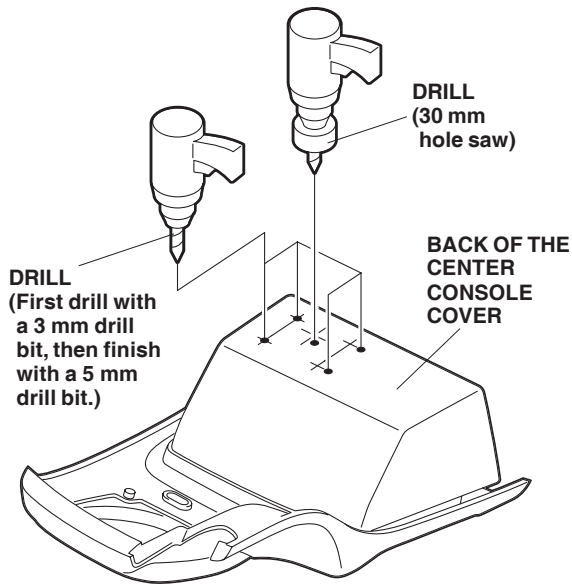

6. Remove all burrs from the edges of the holes.
7. Slide the auxiliary jack into position on the auxiliary jack trim, and install the two self-tapping screws.

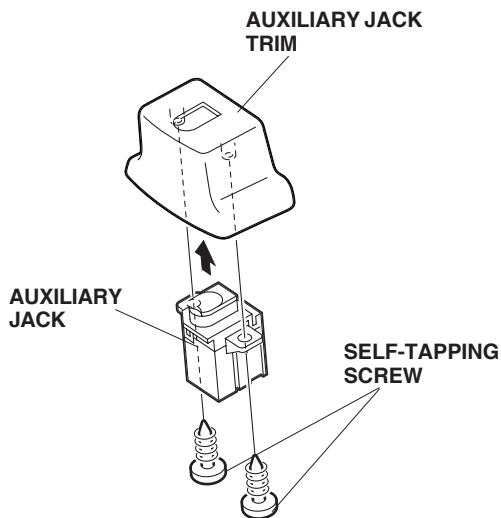

8. Position the auxiliary jack on the pocket of the center console cover, and install the four self-tapping screws.

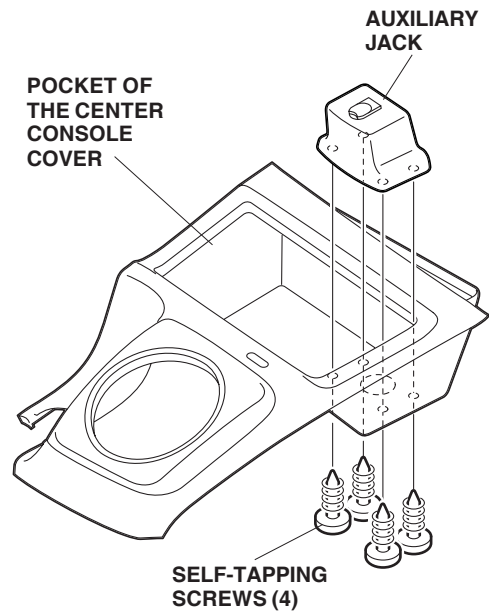

Routing the Auxiliary Jack Harness

9. Wrap two cushion tapes around the auxiliary jack harness at the locations shown.

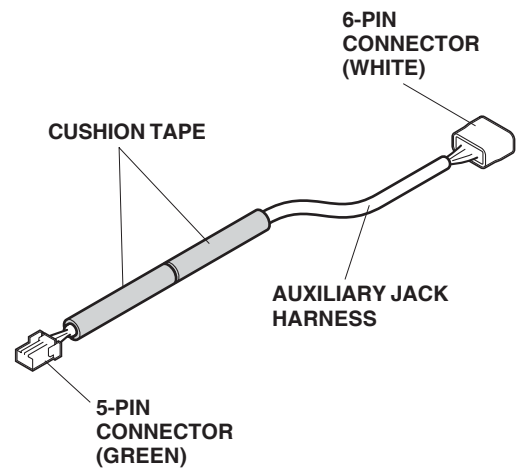

- Locate the vehicle 6-pin connector blue taped to the vehicle connector. Remove the blue tape to free the connector. Plug the auxiliary jack harness 6-pin connector into the vehicle harness 6-pin connector.

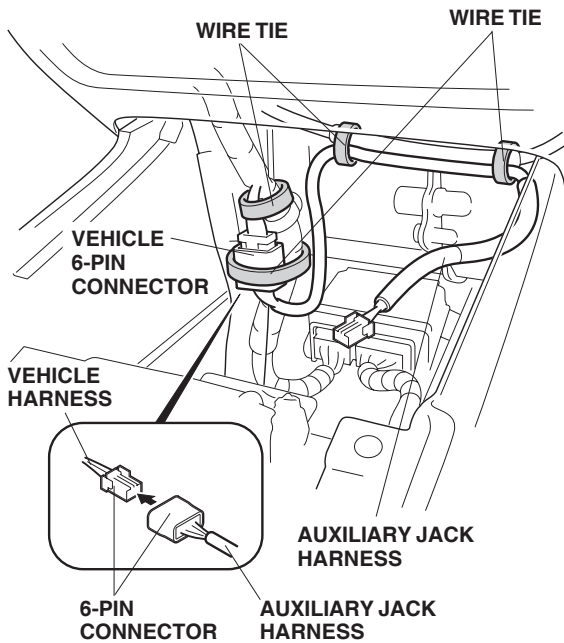

- Secure the auxiliary jack harness to the vehicle harness with four wire ties in the areas shown.
- Plug the auxiliary jack harness 5-pin connector into the auxiliary jack. Reinstall the front console cover and parking brake cover in its original position.

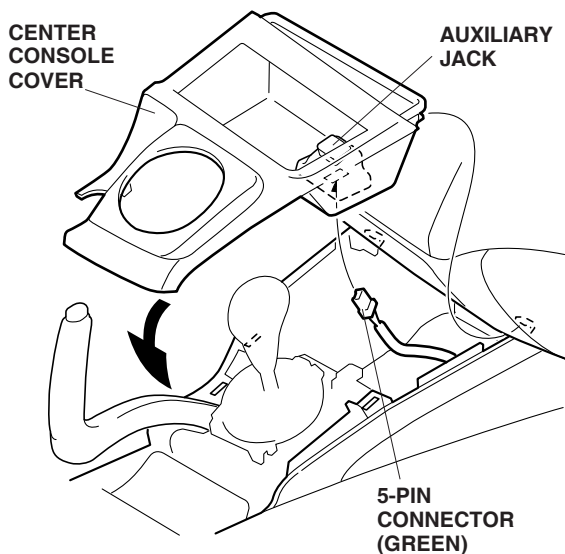

- Check that all wire harnesses are routed properly and all connectors are plugged in.
- Reconnect the negative cable to the battery.
- Enter the customer's radio anti-theft code, and reset the radio station presets.
- Set the clock.
- Check the operation of the auxiliary jack.
- If equipped, reinstall the shift knob.
- Do the ECU idle learn procedure.

- Make sure all electrical items are turned off.
- Start the engine. Hold the engine speed at 3,000 rpm with no load (in Park or neutral) until the radiator fan comes on.
- Let the engine idle for about 5 minutes with the throttle fully closed and with all electrical items off.

NOTE: If the radiator fan comes on during this step, the time when it is operating must not be included in the 5 minutes.

NOTE: When the battery is disconnected, the driver's window AUTO function is disabled.

- Start the engine. Push down on the driver's window switch until the window is fully open.
- Pull up on the driver's window switch to close the window completely, then hold the switch for 2 seconds or more.
- Lower and raise the driver's window to check operation of the driver's window AUTO function.