



INSTALLATION INSTRUCTIONS

Accessory

ENGINE BLOCK HEATER
 P/N 08T44-SNA-100

Application

CIVIC
2 AND 4-DOOR
 (DX, LX, EX)

Publications No.

All 30739

Issue Date

SEP 2005

PARTS LIST

Engine block heater

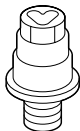

Aluminum washer



Heater harness

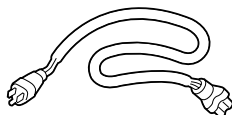

Protective cap

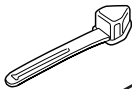

12 Black wire ties

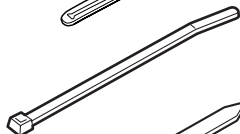

3 Wire ties with clips

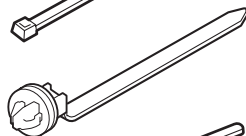

5 White wire ties



TOOLS AND SUPPLIES REQUIRED

Ratchet

10 mm, 19 mm and 24 mm Sockets

Torque wrench

Diagonal cutters

Heavy gloves

Drain pan

Tape measure

White marker

Coolant (Honda Antifreeze/Coolant only, in a 50/50 mixture with water)

NOTE:

- Always use Honda Antifreeze/Coolant. Using a non-Honda coolant can result in corrosion, causing the cooling system to malfunction or fail.
- To avoid burning out the element, do not operate the engine block heater before it is installed in the vehicle and before you add coolant.

INSTALLATION

Customer Information: The information in this installation instruction is intended for use only by skilled technicians who have the proper tools, equipment, and training to correctly and safely add equipment to your vehicle. These procedures should not be attempted by "do-it-yourselfers."

1. Make sure you have the anti-theft code for the radio, then write down the frequencies for the preset buttons.
2. Allow the engine and all cooling system components to cool down.
3. Place a clean drain pan under the radiator drain plug, then remove the drain plug from the bottom of the radiator to drain the coolant. Remove the radiator cap to increase the flow.

NOTICE Radiator coolant will damage paint. Quickly rinse any spilled coolant from painted surfaces.

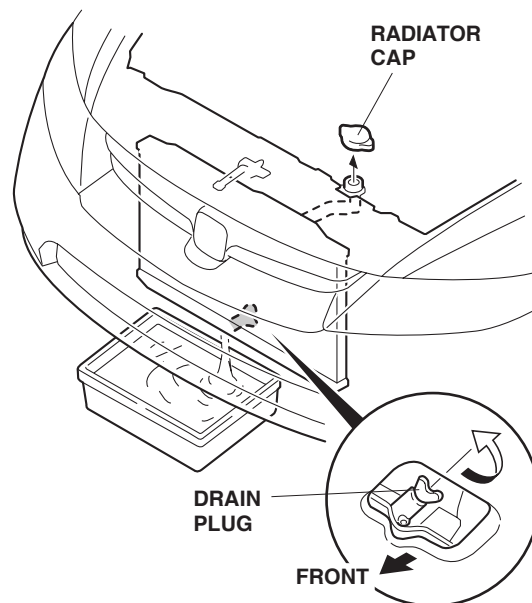

4. Using a tape measure, measure the heater harness and mark it at the A and B points shown.
 - Without fog lights, Install the wire tie with clip to the heater harness at point C.

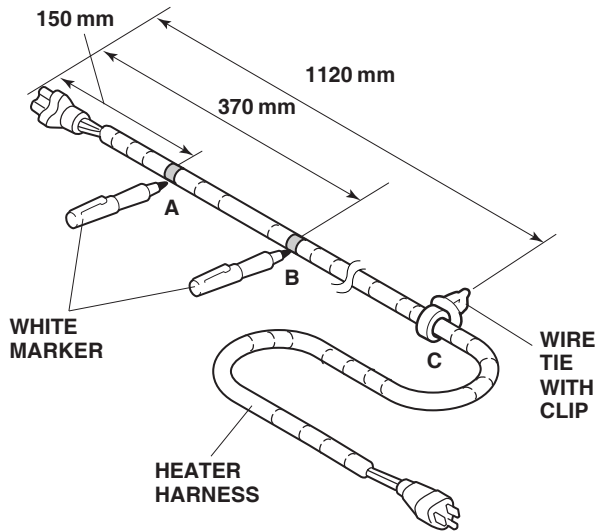

- 4-Door with fog lights, Install the wire ties with clips to the heater harness at points C and D.

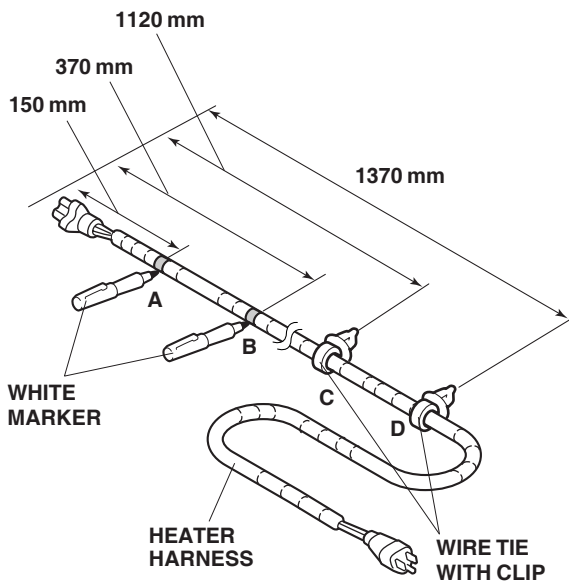

5. Disconnect the negative (-) cable from the battery, then open the positive cable cover and disconnect the positive (+) battery cable from the battery. Remove the two battery holder nuts and remove the battery holder, then remove the battery upper cover, battery and battery under cover.

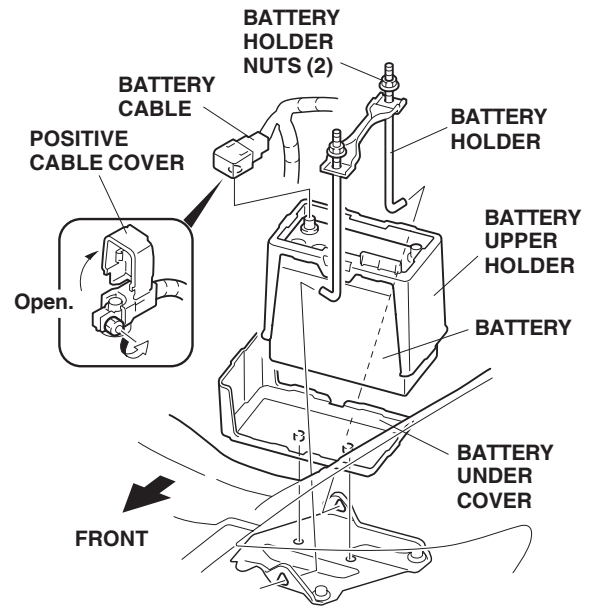

6. Locate and remove the engine block drain bolt and washer. Coolant remaining in the engine jackets flows out of the bolt hole when the bolt is removed. (Retain the bolt and washer in case the block heater is removed.)

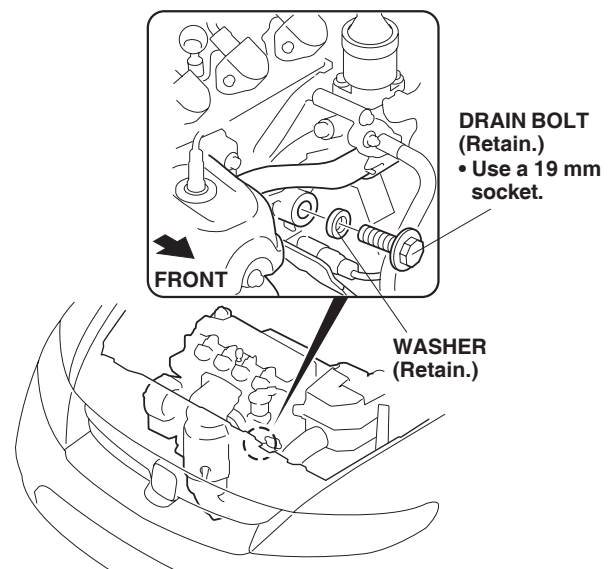

- Install the new aluminum washer and the engine block heater into the bolt hole using a 24 mm socket and a torque wrench. Torque the engine block heater to 60 N·m (6 kgf·m, 44 lbf-ft).

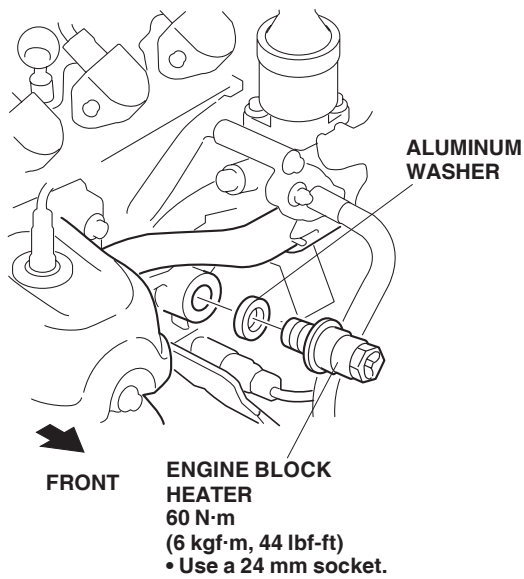

- Plug the connector end of the heater harness into the engine block heater. Route the heater harness as shown and secure it to the vehicle bracket with one white wire tie at the white mark (point A) you made.

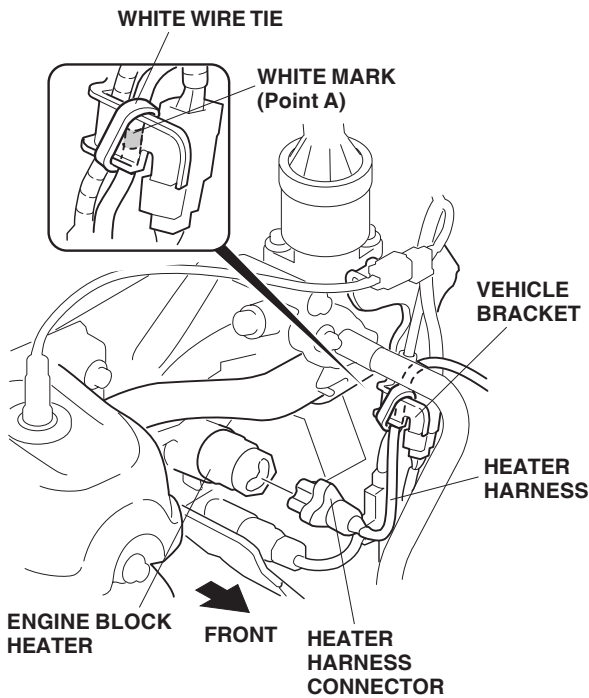

- Secure the heater harness to the fan shroud rib with one black wire tie at the white mark (point B). Route the heater harness under the vehicle frame.

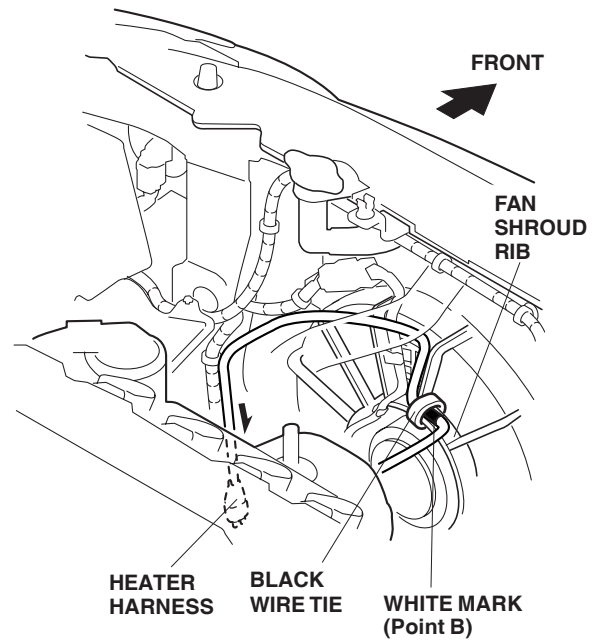

- Secure the wire tie with clip, attached at point C, to the vehicle frame and route the heater harness to the front bumper opening.

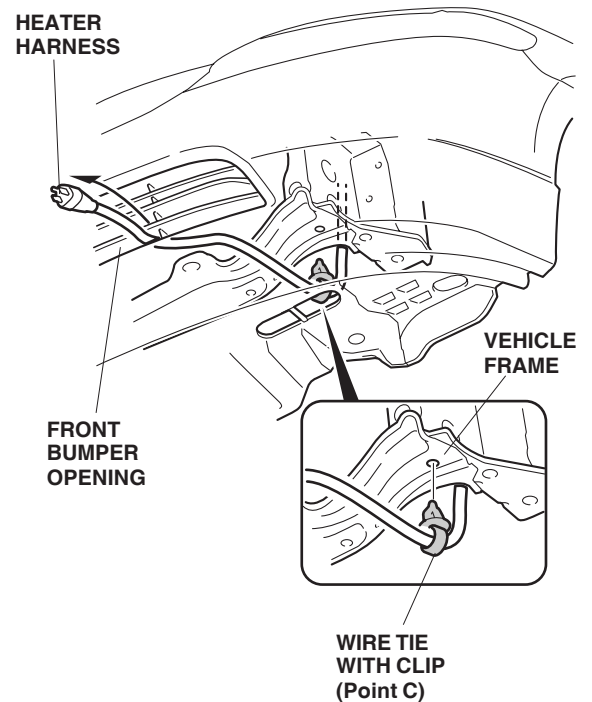

- Secure the heater harness to the fan shroud rib and the vehicle harness using five black wire ties.

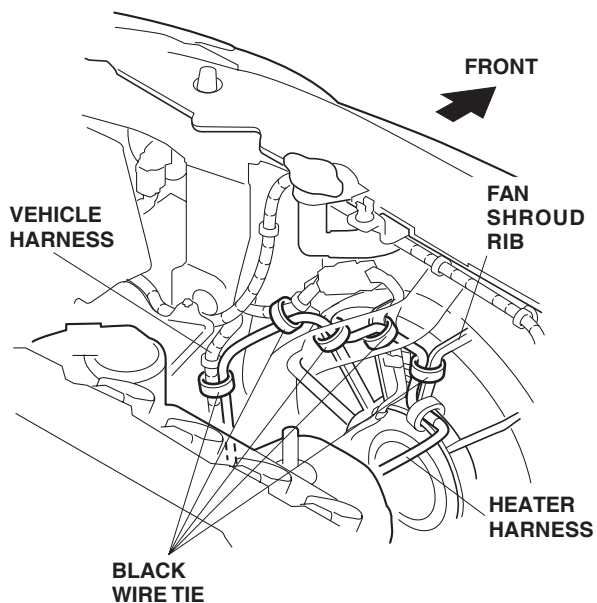

- Route the heater harness inside the bumper and secure it with four black wire ties.

4-Door Without Fog Lights

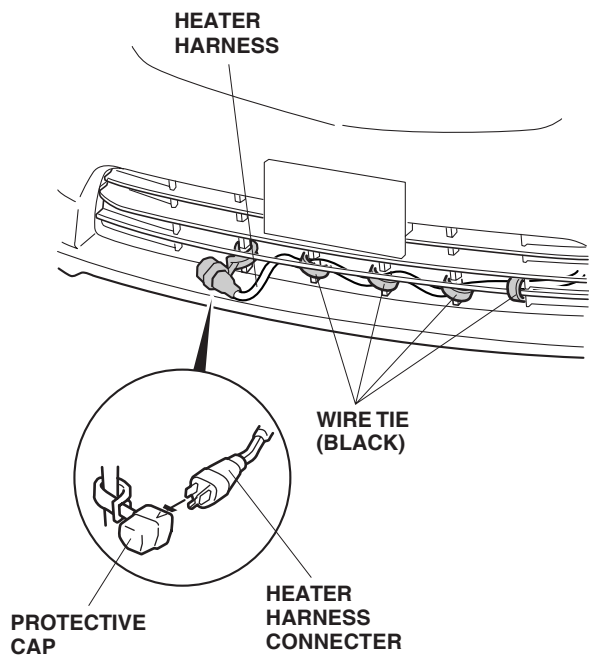

4-Door With Fog Lights

- Remove the four clips from the bottom of the front bumper.

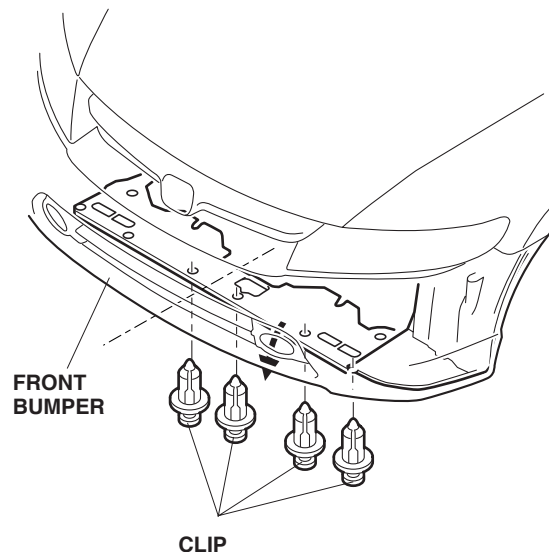

- Route the heater harness inside the bumper opening and secure it with three black wire ties as shown. Secure the heater harness to the fog light bracket with the wire tie with clip attached at point D.

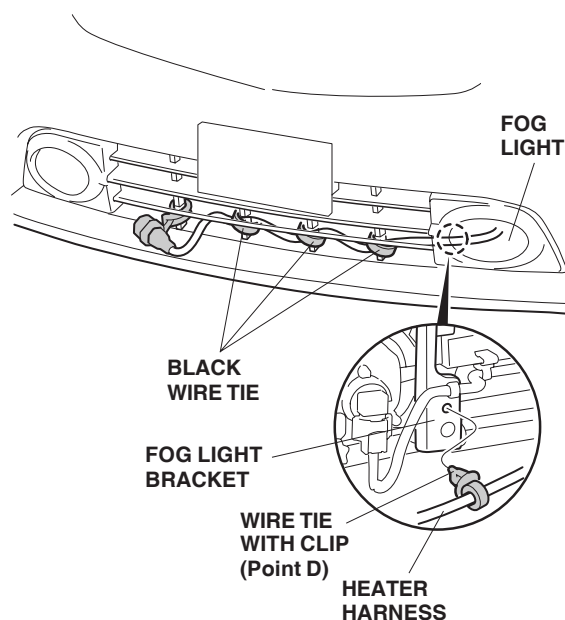

2-Door

- Route the heater harness on the inside of the bumper opening and secure it with the two black wire ties.

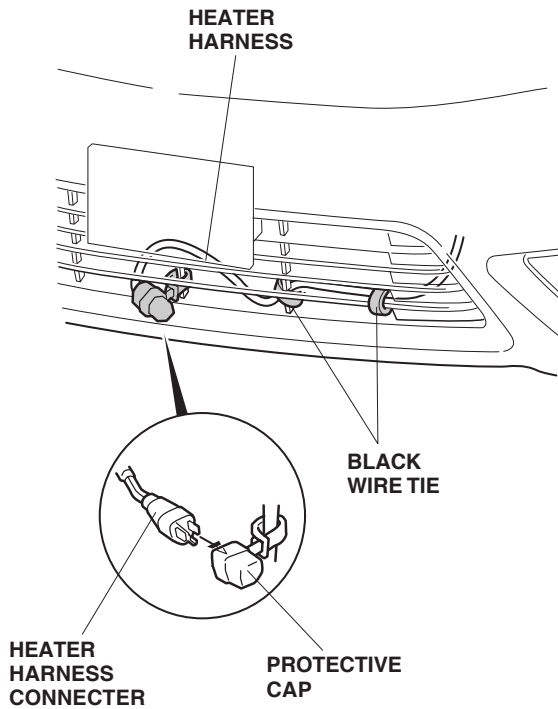

- Attach the protective cap to the grille, and plug the connector of the heater harness into the protective cap.

- Reinstall all removed parts.
 - Reinstall the radiator drain plug.
 - Fill the system with the recommended coolant. Follow the instructions described in the service manual to fill and bleed the cooling system.
 - Check the coolant reservoir for correct level and check the cooling system for signs of leakage. Repair as necessary.
 - Check that the heater harness is routed properly and all connectors are plugged in.
 - Put the drain bolt (removed in step 5) in the glove box.
 - Reconnect the negative cable to the battery.
 - Enter the customer's radio anti-theft code, and reset the radio station presets.
 - Reset the clock.
- NOTE: Whenever the battery is disconnected, the driver's AUTO window function is disabled.
- Start the engine. Push down on the driver's window switch until the window is fully open.
 - Pull up on the driver's window switch fully to close the window completely, then hold the switch for 2 seconds.
 - Test the AUTO window function.