



INSTALLATION INSTRUCTIONS

Accessory
FOG LIGHT
P/N 08V31-SVA-100

Application
CIVIC
2-DOOR

Publications No.
All 30890-31630
Issue Date
DEC 2005

NOTE: The foglights cannot be installed on 2-door vehicles equipped with interior illumination.

PARTS LIST

Right fog light

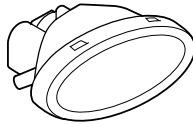

Left fog light



Right bracket

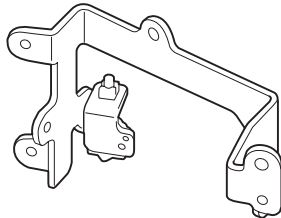

Left bracket

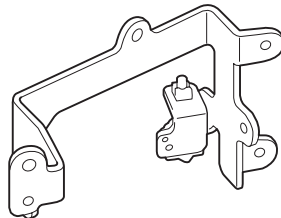

Switch harness

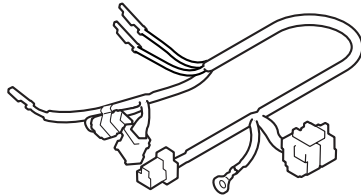

Fog light harness

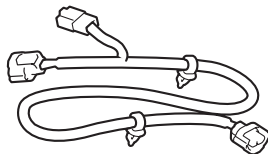

Sub harness

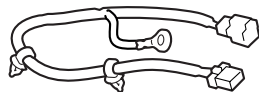

Switch

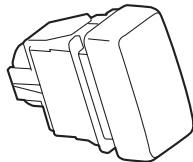

11 Wire ties

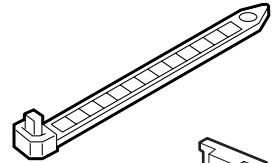

Clip



4 Stepped screws



2 Washer screws



Switch trim
(DX model only)

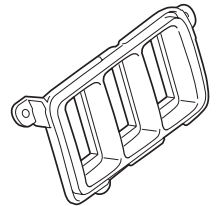

6 Self-tapping screws



Fuse (20A)



Relay

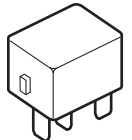

5 Wire ties with clips

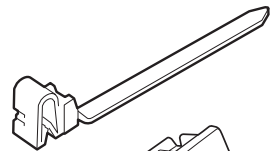

2 Switch covers
(DX model only)

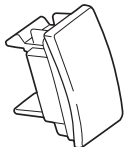

Template

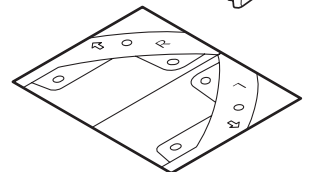

Ground bolt



TOOLS AND SUPPLIES REQUIRED

Phillips screwdriver
Flat-tip screwdriver
Ratchet
10 mm Socket
Drill
3 mm and 10 mm Drill bit
Pushpin
Utility knife
Gloves
Eye protection (face shield, safety goggles, etc.)
File
Masking tape
Scissors
Blanket
Shop towel
6 mm Hexagon wrench

Illustration of Fog Lights installed on the Vehicle

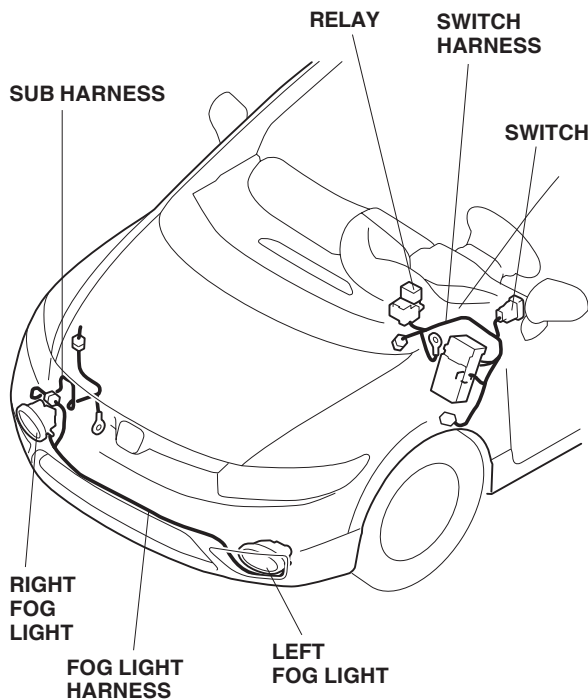

INSTALLATION

Customer Information: The information in this installation instruction is intended for use only by skilled technicians who have the proper tools, equipment, and training to correctly and safely add equipment to your vehicle. These procedures should not be attempted by "do-it-yourselfers."

1. Make sure you have the anti-theft code for the radio, then write down the frequencies for the preset buttons.
2. Disconnect the negative cable from the battery.
3. Remove the radiator cover (four clips).

CLIPS (2)

- Pull out the clip vertically from the panel surface.

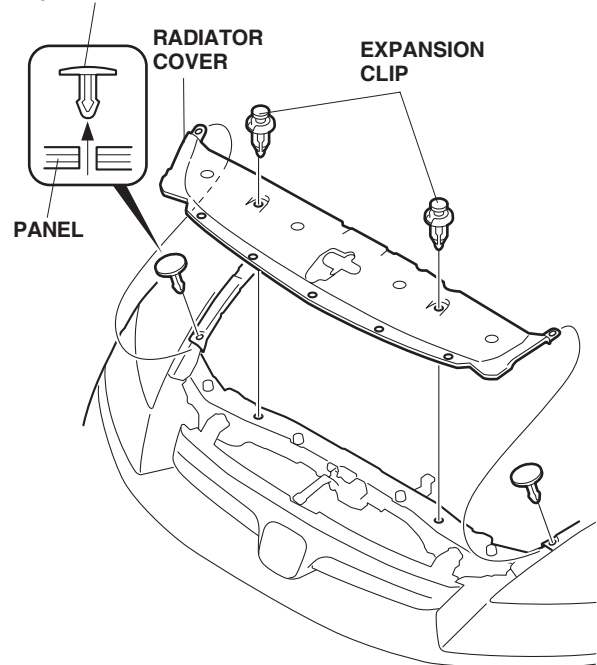

- With the help of an assistant, remove the front bumper (ten clips and two self-tapping screws). Set the front bumper on a blanket.

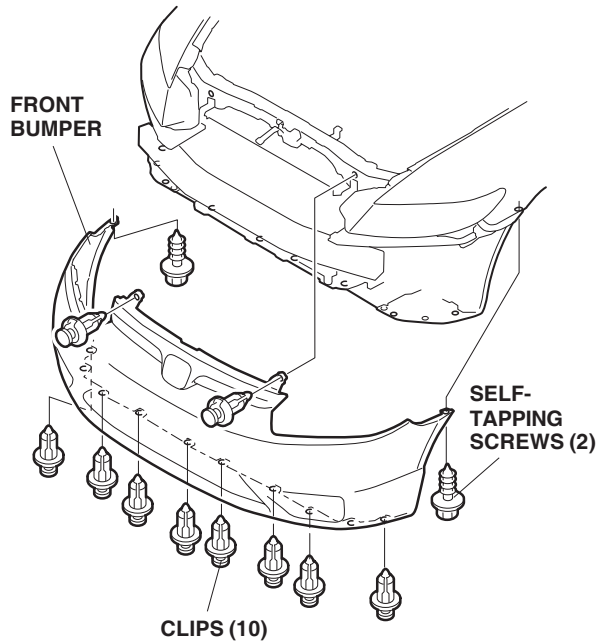

- Apply masking tape to the front bumper around the left fog light area.

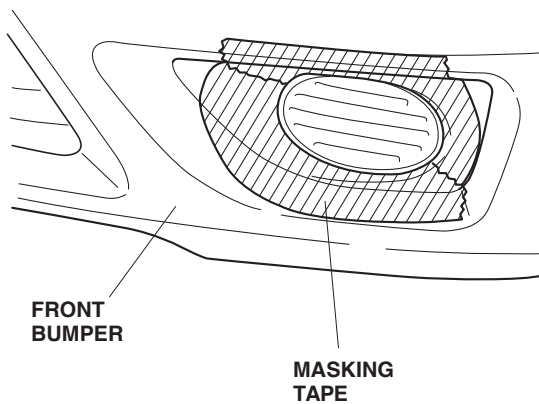

- Using a utility knife, and working from the front of the bumper, carefully cut out the front bumper in the area shown. Take care not to damage the front bumper. Remove any burrs from the edges of the hole.

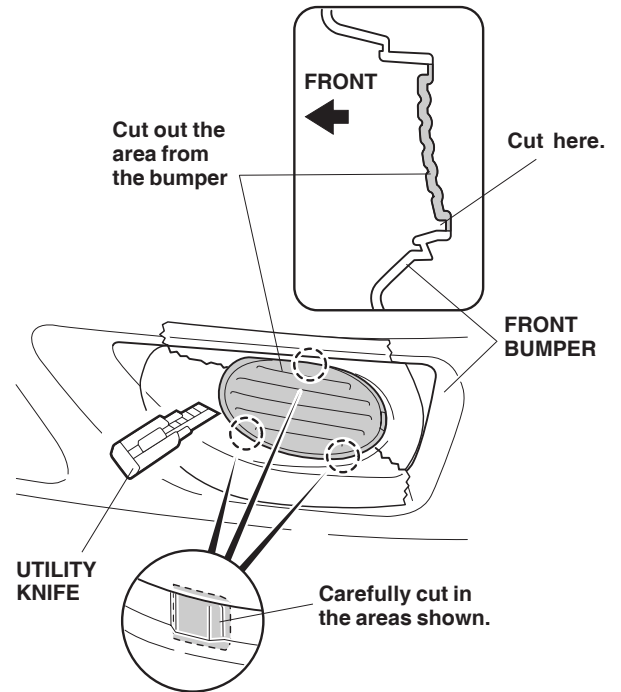

- Repeat steps 5 and 6 to cut the bumper for the right fog light.

- Using scissors, cut out the template.

- The template "L" is the mirror image of the template "R".

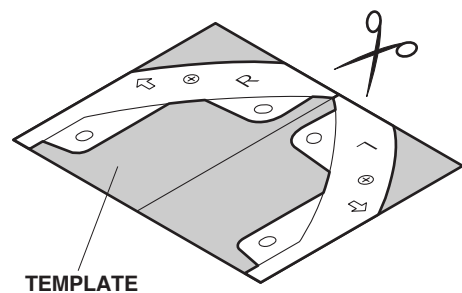

9. Tape the template marked "L" to the inside of the front bumper below the left fog light opening. Using a pushpin, pierce the bumper through the mark in the template.

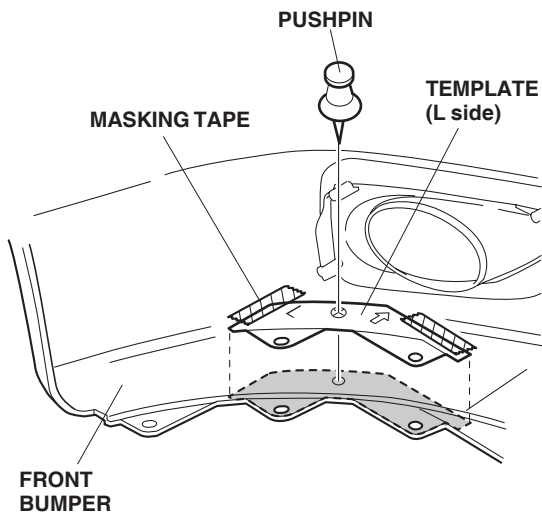

10. While wearing eye protection, drill a 10 mm hole through the bumper at the marked location. First drill with a 3 mm drill bit and finish with a 10 mm drill bit.

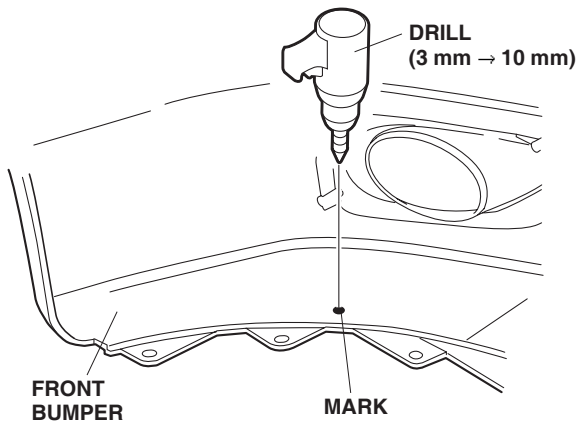

11. Repeat steps 9 and 10 to mark and drill the right side of the front bumper.

12. Position the left bracket on the left fog light, and install the two stepped screws and one washer screw. Tighten the screws securely.

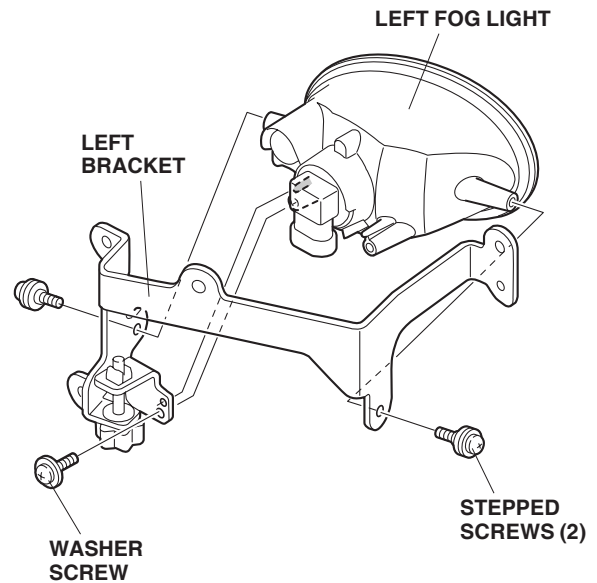

13. Inside the front bumper, slide the left fog light into the cutout you made, and secure it with three self-tapping screws.

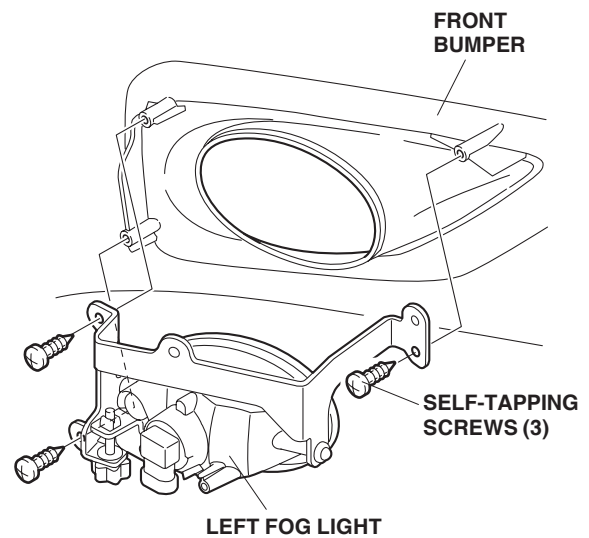

14. Repeat steps 12 and 13 to install the right fog light.

- Route the fog light harness along the inside of the front bumper, and plug the 2-pin connectors into the fog lights.

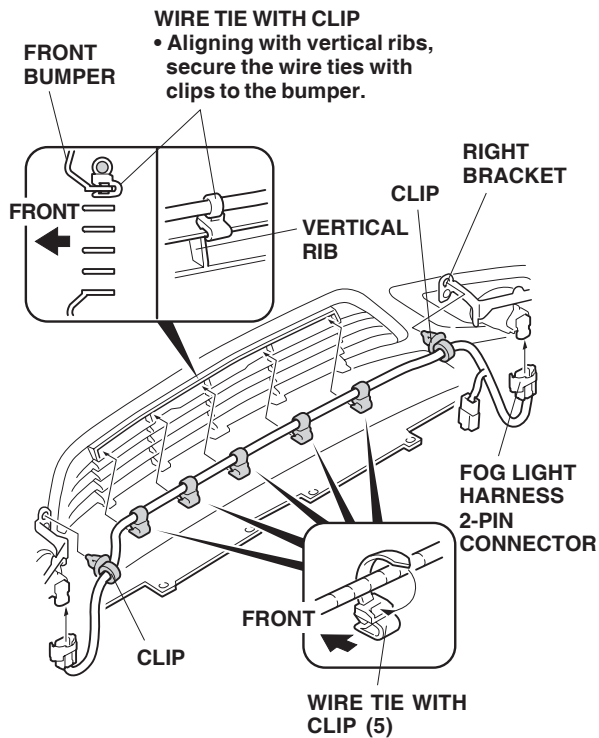

- Secure the clips attached to the fog light harness to the left and right fog light brackets.
- Loosely install five wire ties with clips on the fog light harness.
- Align the five wire ties with clips with the vertical ribs of the front bumper as shown, and tighten the five wire ties with clips securely.

- Slide the clip onto the 2-pin connector on the fog light harness, and secure the connector to the right bracket.

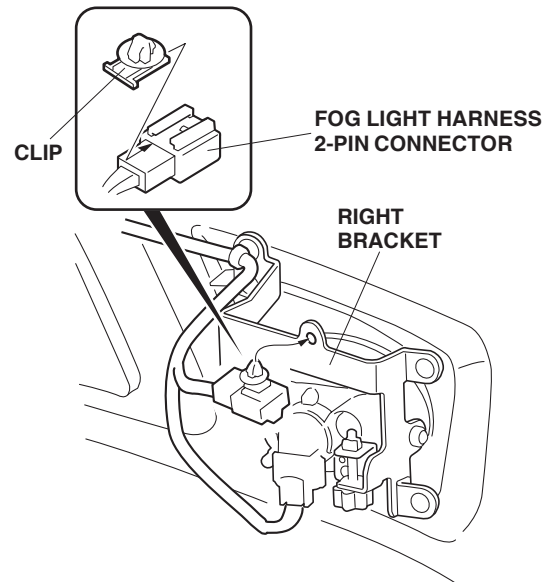

- Remove one bolt from the washer reservoir tank and loosen the two bolts.

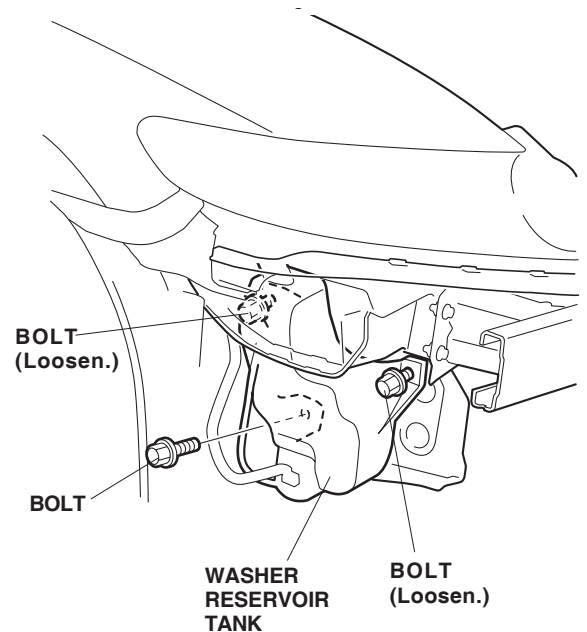

21. Locate the 1-pin connector blue-taped to the vehicle harness, and remove the blue tape to free the 1-pin connector. Plug the 1-pin connector you just freed into the 1-pin connector from the subharness.

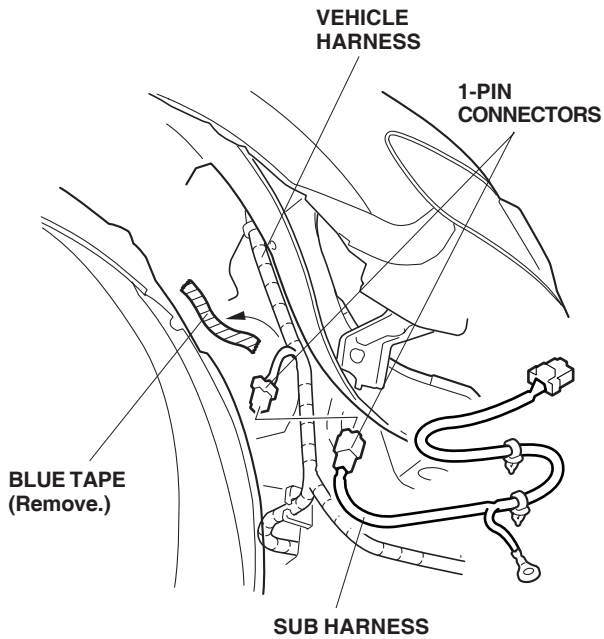

22. Route the subharness between the washer reservoir tank and vehicle panel, and route it as shown.
23. Secure the subharness ground terminal to the vehicle frame using a ground bolt.

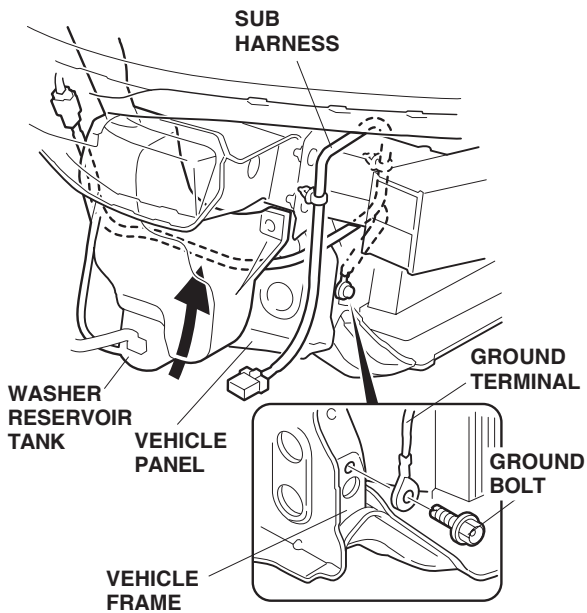

24. Secure the two clips on the subharness to the vehicle frame. Secure the subharness to the vehicle harness using two wire ties.

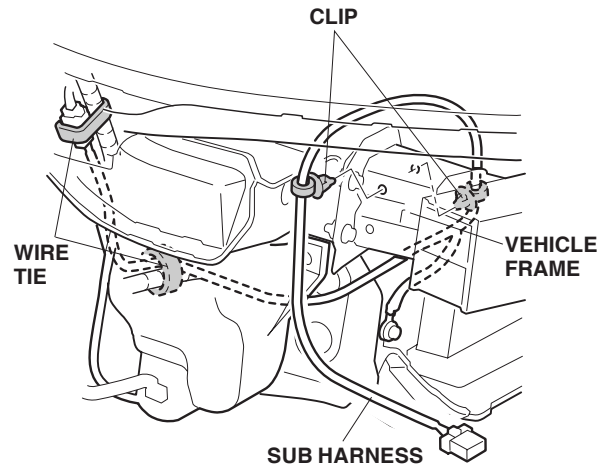

25. Reinstall the washer reservoir tank.
26. Plug the 2-pin connector on the subharness into the 2-pin connector on the fog light harness.

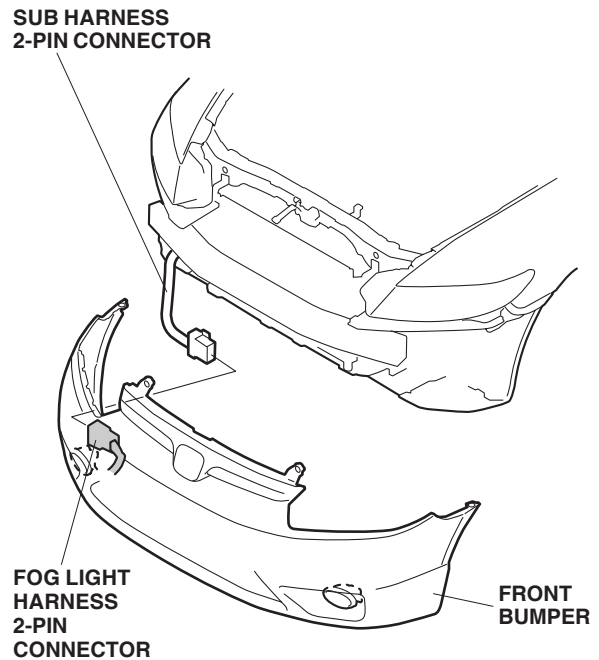

27. Reinstall the front bumper.

28. Remove the cover from the trunk lid/fuel fill door opener (six retaining tabs), and remove one self-tapping screw.

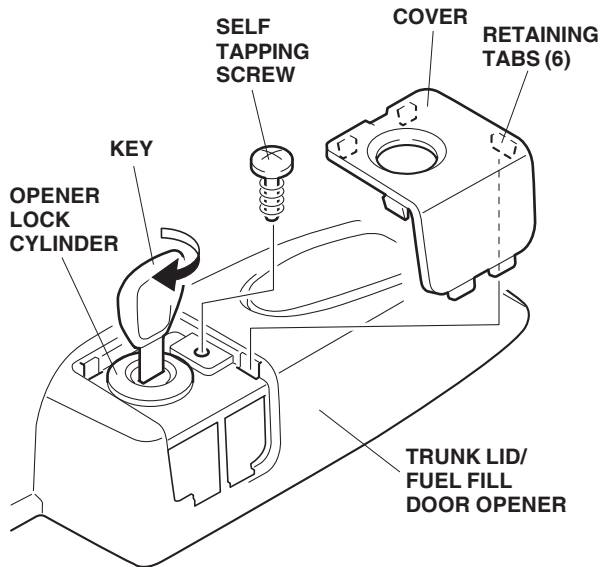

29. Using the ignition key, unlock the opener.
 30. Raise the front edge of the left front door sill trim (six clips, retaining tab, and hook).

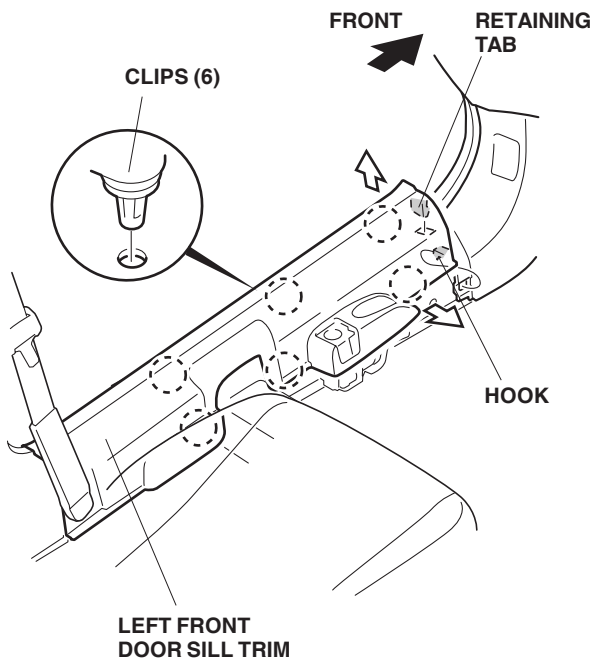

31. Remove the footrest.

- Using a hexagon wrench, remove the lower clip from the stud bolt.
- Using a flat-tip screwdriver, remove the upper clip from the stud bolt.

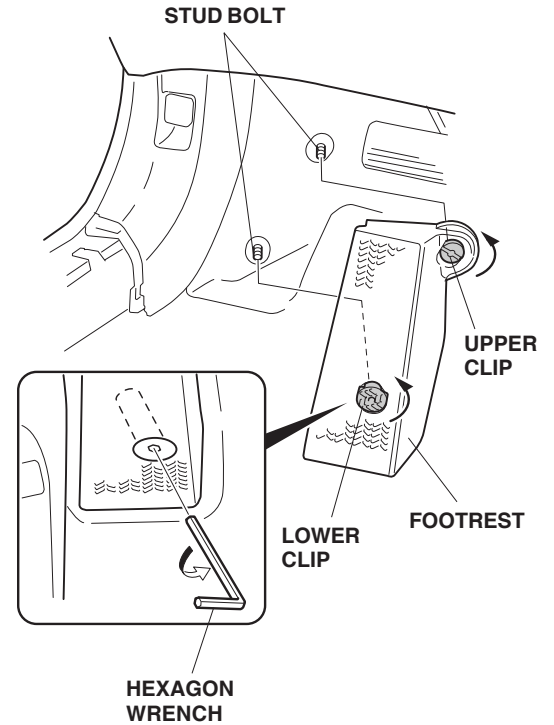

32. Pull away the weatherstrip from the left kick panel and remove the left kick panel (two clips).

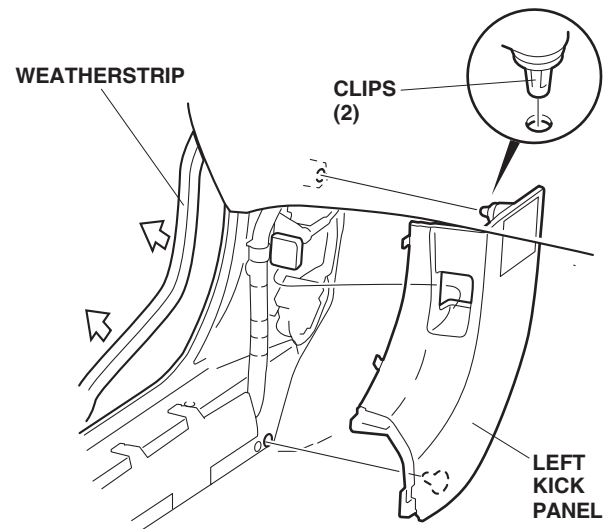

33. If equipped, remove the driver's dashboard under cover (turn the lock knob 90° counterclockwise, and release the two clips and pin).

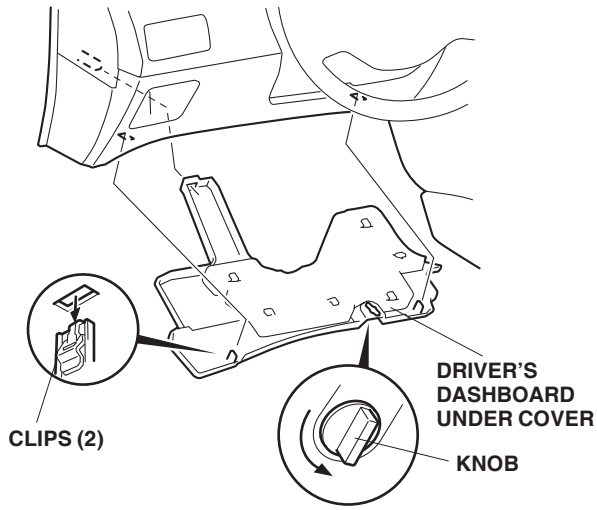

34. Remove the driver's dashboard lower cover (eight clips).

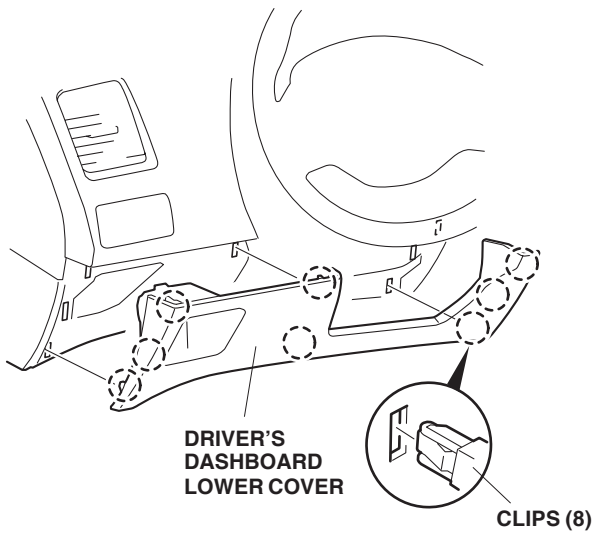

DX model: Continue with step 35.
All other models: Go to step 38.

35. Lower the tilt/telescopic lever, and move the steering wheel down and toward you. After moving the steering wheel, return the tilt/telescopic lever to its original position.

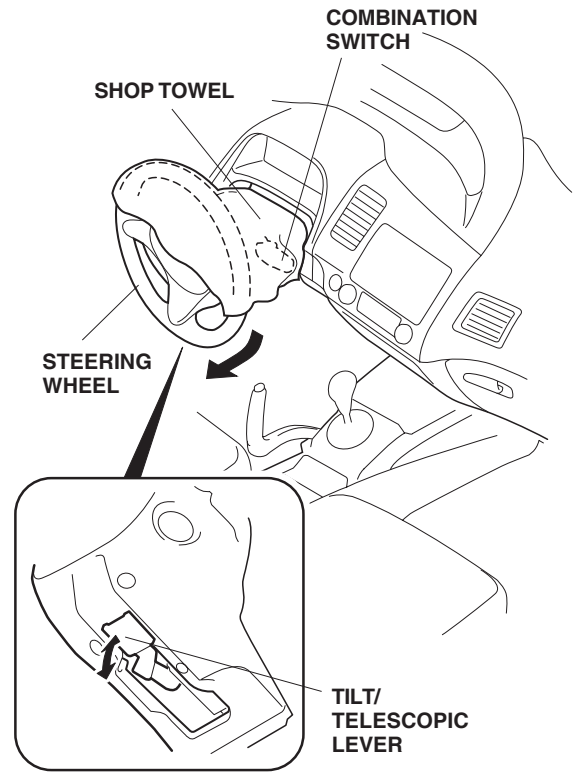

36. Cover the combination switch with a shop towel to protect it from damage.

37. Apply masking tape to the instrument panel as shown, and remove the meter panel (one self-tapping screw, 11 clips, and one connector).

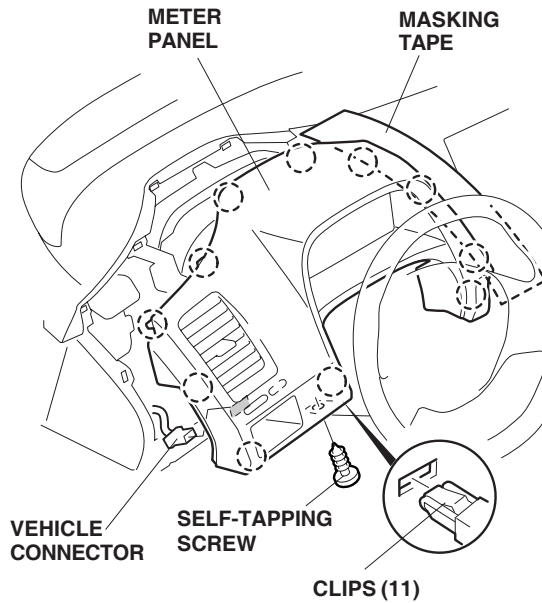

38. Remove the vehicle's green 42-pin connector, white 34-pin connector, and the blue 21-pin connector from the fuse box by pushing the retaining tab and raising the lock on each connector. Close the lock on the white 34-pin connector, then slide the cover off the connector.

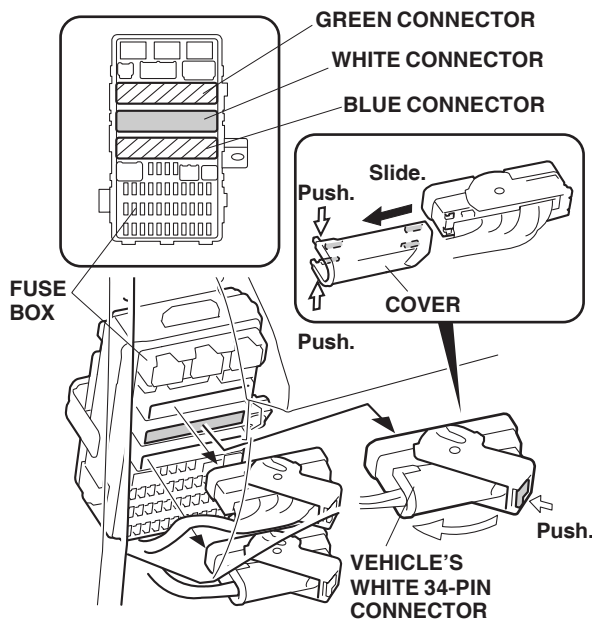

39. Insert the white/red and blue terminals from the switch harness into the white 34-pin connector. Reinstall the cover.

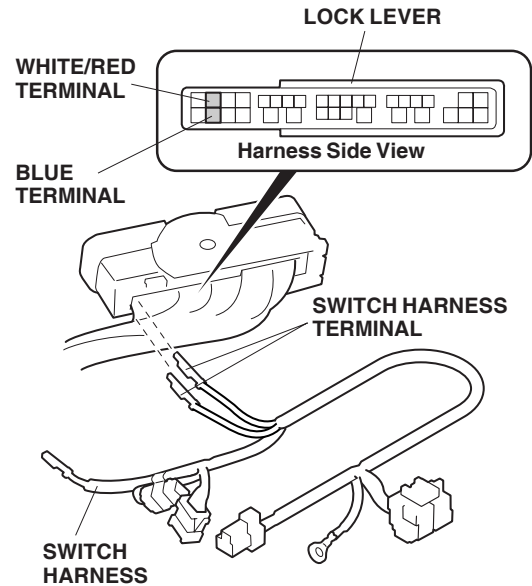

40. Reinstall the three vehicle connectors.
41. Plug the switch harness 6-pin connector into the fuse box.

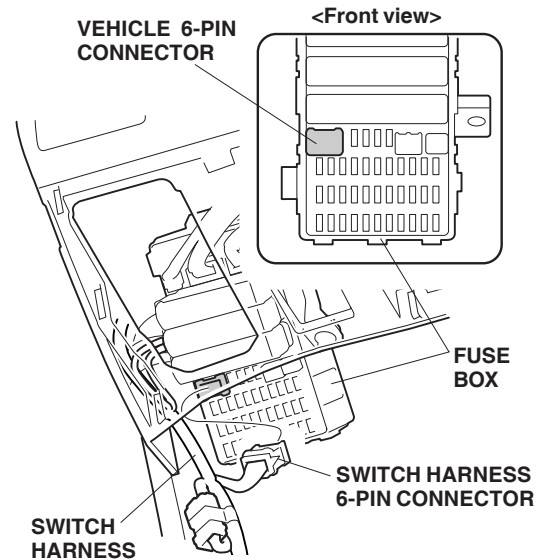

NOTE: If the fuse box 6-pin connector is already being used by another accessory, unplug its 6-pin connector from the fuse box. Locate the 6-pin connector taped to the switch harness, and remove the dummy connector from the connector. Plug the other accessory's harness 6-pin connector into the switch harness, and plug the switch harness 6-pin connector into the fuse box.

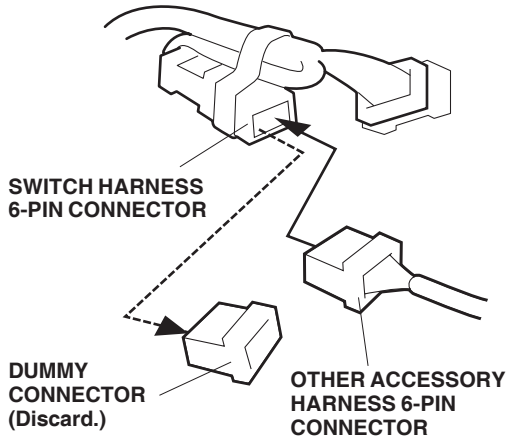

42. Route the terminal on the switch harness as shown.

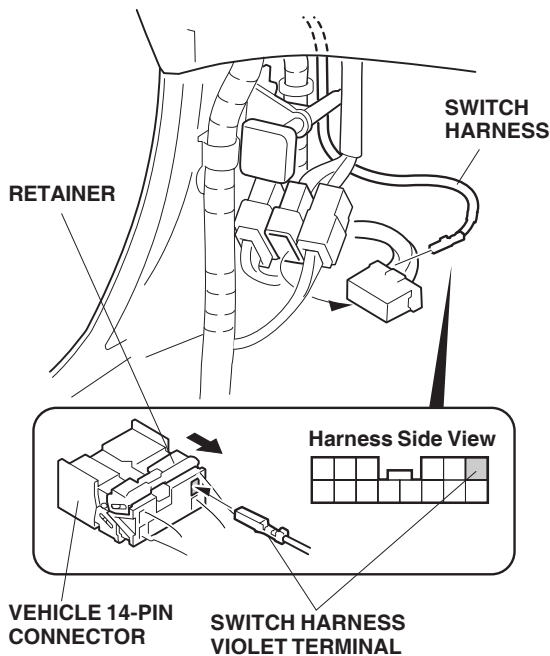

43. Disconnect the vehicle 14-pin connector.
44. Slide back the retainer on the vehicle 14-pin connector, and insert the violet terminal from the switch harness into the 14-pin connector. Close the retainer, and reconnect the 14-pin connector.

45. Route the switch harness relay block above the knee bolster.

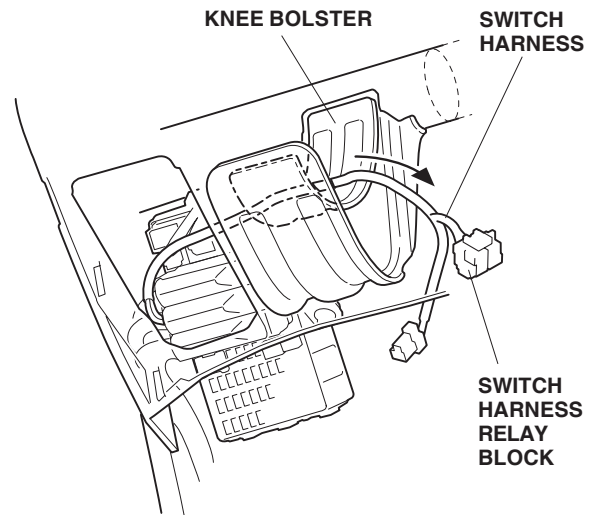

46. Plug the relay into the switch harness relay block, then slide the relay block onto the vehicle bracket stay.

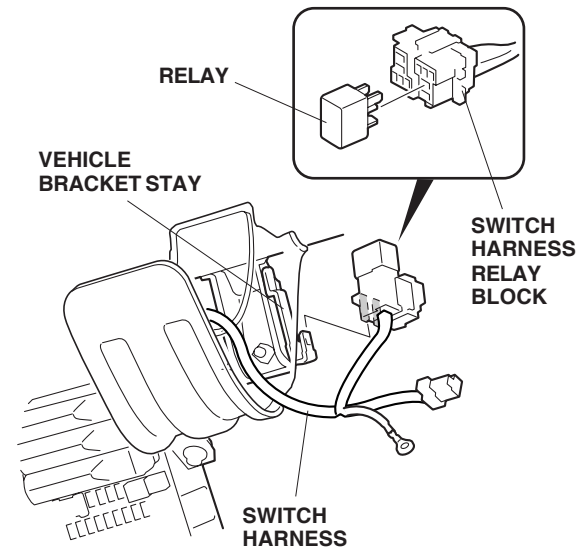

47. Remove the vehicle ground bolt. Install the switch harness ground terminal, then reinstall the ground bolt.

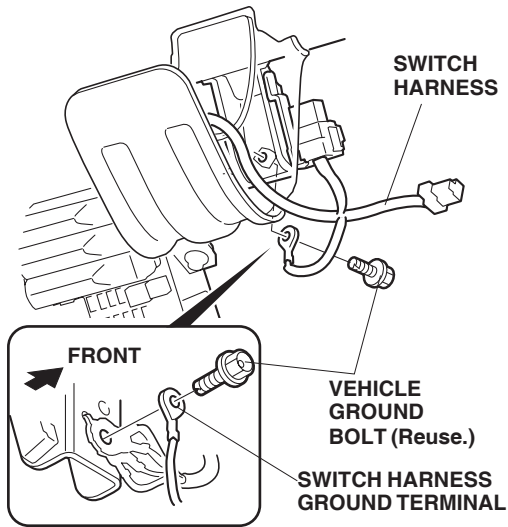

48. Locate the 1-pin connector blue-taped to the vehicle harness. Plug the 1-pin connector into the switch harness 1-pin connector.

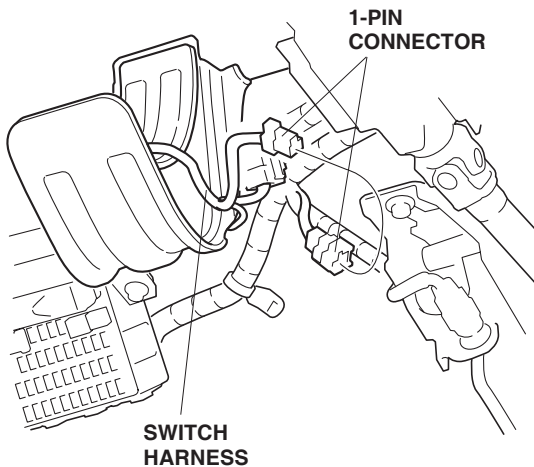

49. Install the fog light switch:

DX Model

- Remove the pocket from the meter panel (three self-tapping screws).

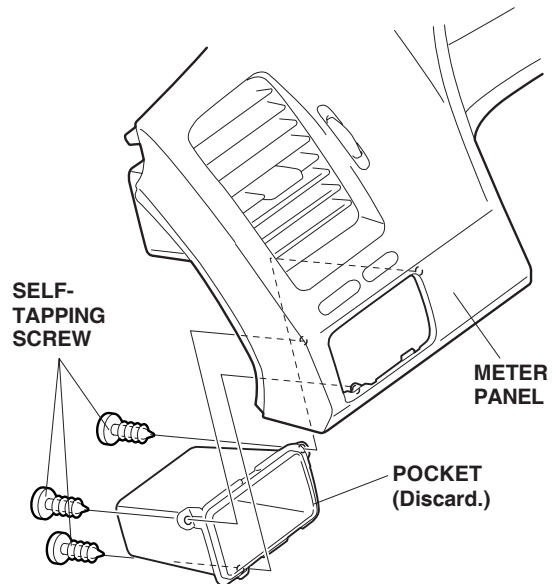

- Install the switch trim to the meter panel with the three self-tapping screws.

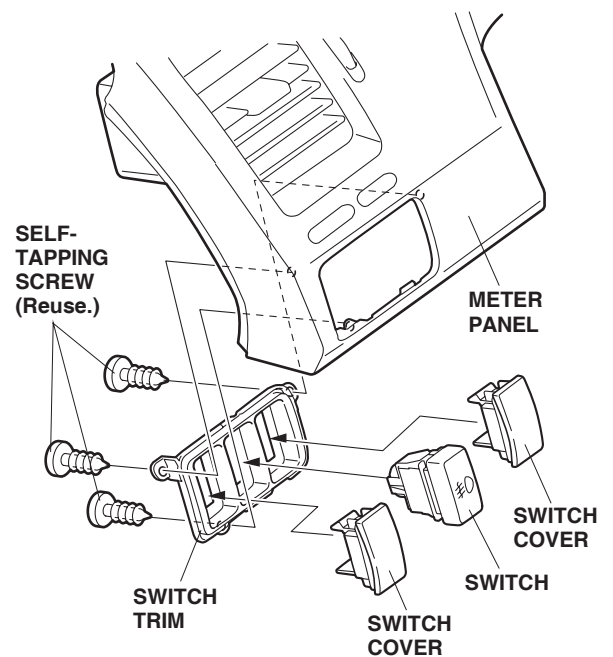

- Install the switch and two switch covers into the switch trim.

- Plug the switch harness 5-pin connector into the switch, reconnect the one connector, and reinstall the meter panel.

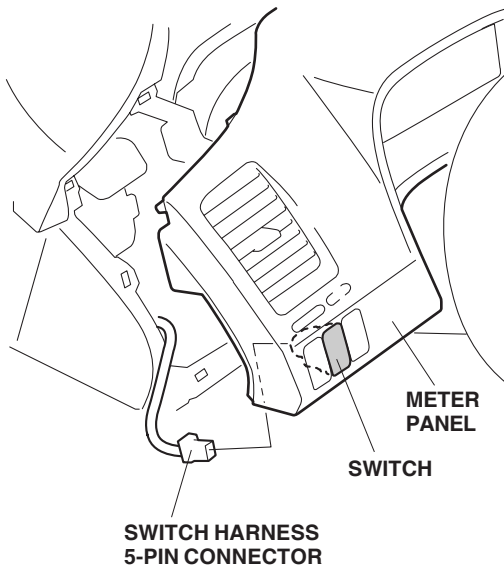

LX, EX, Si model

- While wearing gloves, push the switch cover out from the inner side of the meter panel.

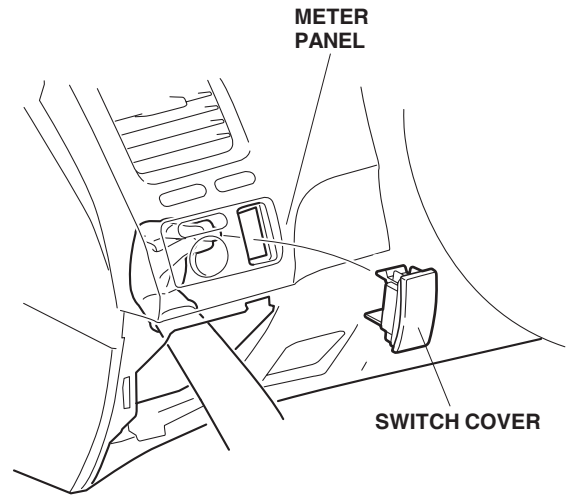

- Route the switch harness 5-pin connector through the hole.

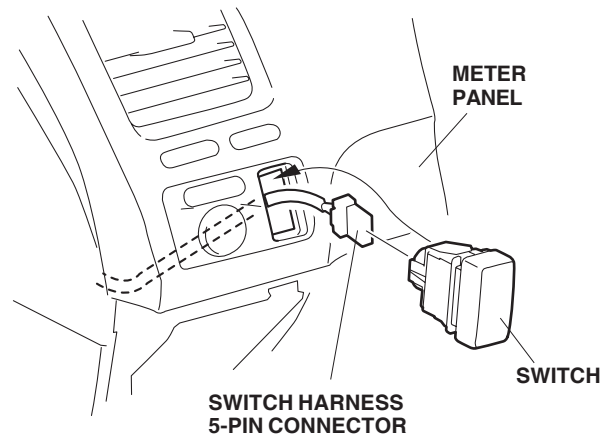

- Plug the switch harness 5-pin connector into the switch and install the switch into the meter panel.

50. Secure the switch harness to the vehicle harness and to the knee bolster with nine wire ties in the areas shown.

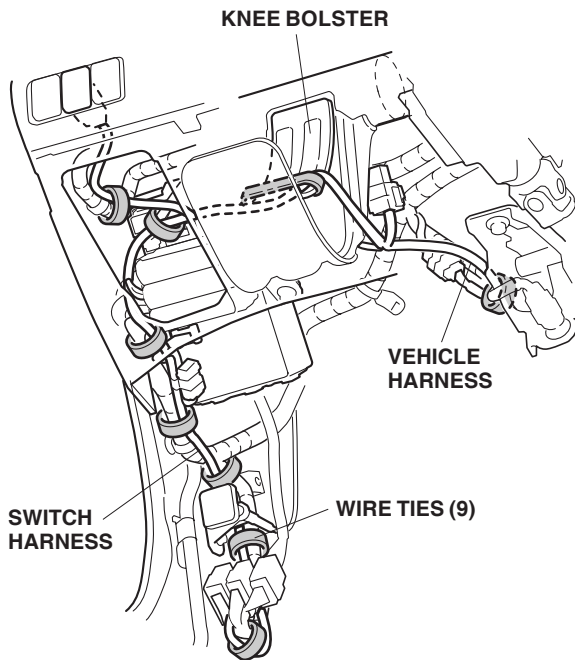

51. Install the 20A fuse into the fuse box in the location shown.

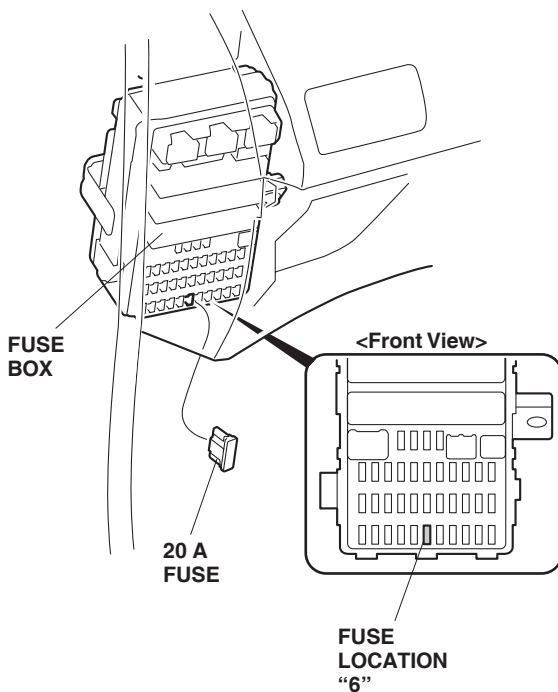

52. Check that all wire harnesses are routed properly and all connectors are plugged in.
53. Reinstall all removed parts.
54. Reconnect the negative cable to the battery.

USE AND CARE

How to Operate the Fog Lights

- Turn the light switch to the "D" position (headlights on low beam).
- Press the fog light switch (indicator is on).

NOTE: The fog light lenses can cloud when the outside temperature is cold; this is normal and should go away in warm weather.

Fog Light Aiming Adjustment

55. Adjust the fog light:
- Adjust the aim according to local laws and regulations.
 - To adjust, turn the aiming adjustment knob in or out until the correct aim is obtained.

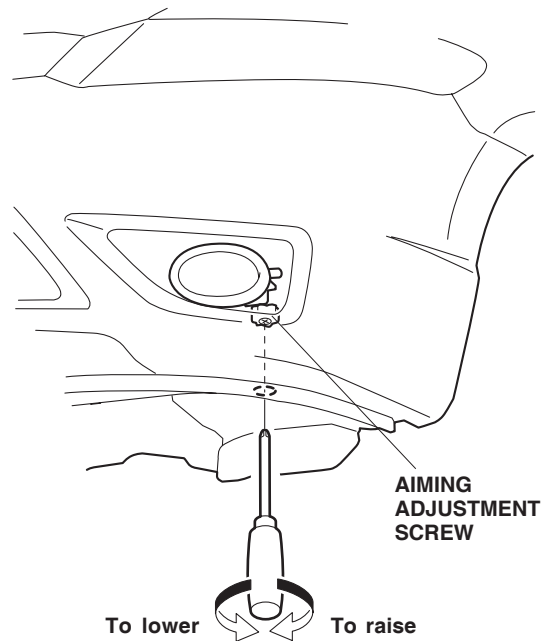

56. Reset the clock, and reset the radio station presets.

NOTE: Whenever the battery is disconnected, the driver's AUTO function is disabled.

57. Start the engine. Push down on the driver's window switch until the window is fully open.

58. Pull up on the driver's window switch fully to close the window completely, then hold the switch for 2 seconds or more.

59. Test the window AUTO function.

BULB REPLACEMENT

1. Remove the seven clips from the bottom of the front bumper, then pull down the under cover and inner fender.

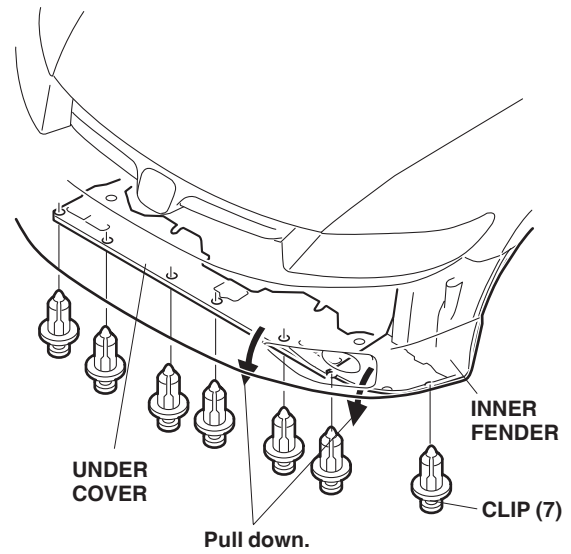

2. Disconnect the fog light connector.
3. Remove the bulb.

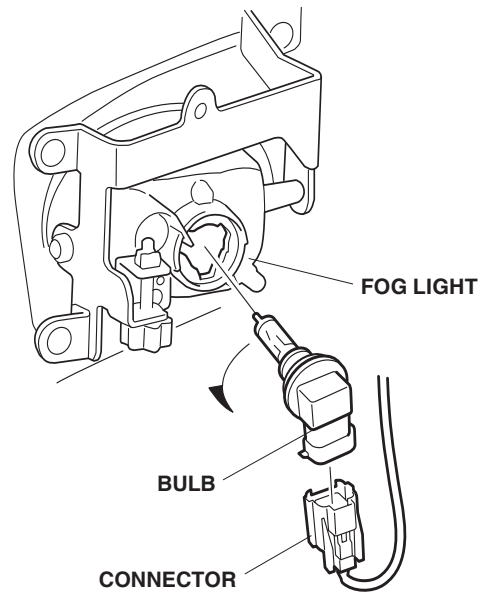

4. Install the new bulb and socket into the fog light.
 - Use only a genuine Honda halogen light bulb of specified wattage.

Rating: 12V 55W H11 Halogen Light Bulb P/N 33165-S5A-003
 - Do not touch the bulb. Oily or greasy substances on the bulb can shorten its service life due to the heat produced when the bulb is turned on. If the bulb is accidentally touched, wipe it clean with a soft cloth that has been dampened with a denatured alcohol or a mild detergent solution.
 - Align the tab on the fog light with the cutout in the bulb when installing the new bulb. If not aligned, the fog light may annoy oncoming drivers.

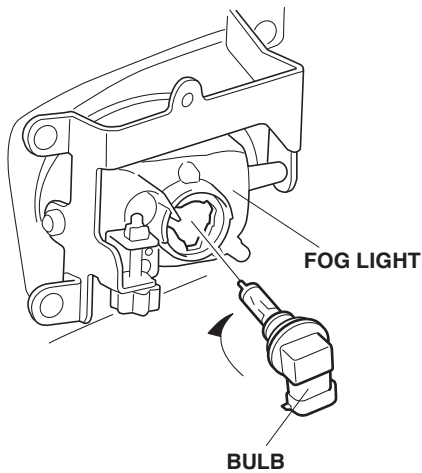

5. Reinstall the removed parts in the reverse order of removal.
 - Check that the wire harnesses are not pinched.
6. Check the operation of the fog light; adjust the aiming if necessary.

CIRCUIT DIAGRAM

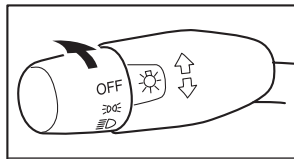
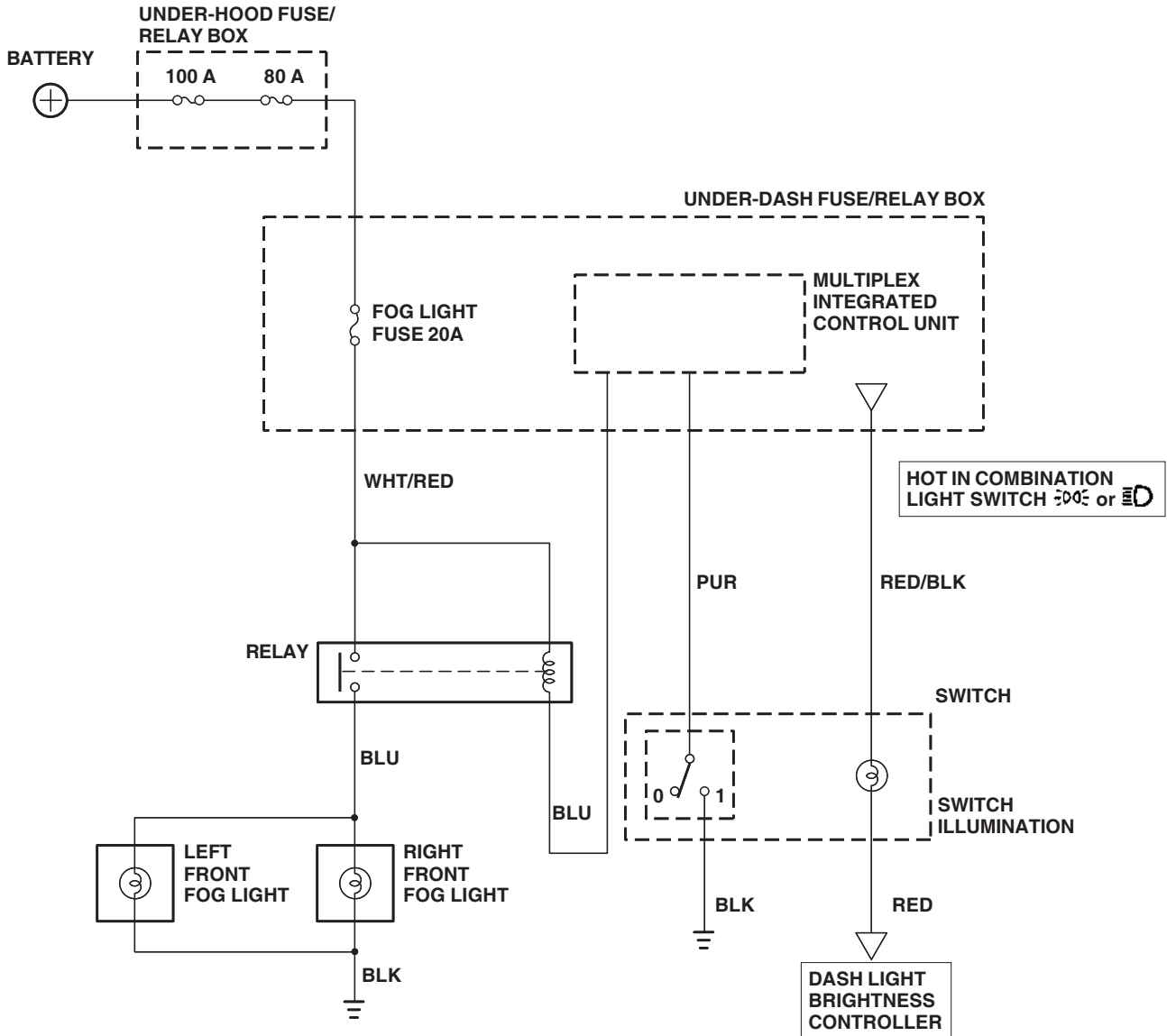

		HEADLIGHT SWITCH			
		OFF			
				Low	Hi
	OFF	-	-	-	-
	ON	-	-	ON	-

BLK	BLACK	BRN	BROWN
YEL	YELLOW	ORN	ORANGE
BLU	BLUE	PUR	PURPLE
GRN	GREEN	NAT	NATURAL
RED	RED	PNK	PINK
WHT	WHITE	GRY	GRAY
LT BLU	LIGHT BLUE	LT GRN	LIGHT GREEN