



INSTALLATION INSTRUCTIONS

Accessory

ALUMINUM WHEEL
P/N 08W16-SNA-100-A

Application

2008 CIVIC
2 AND 4-DOOR

Publications No.

All 38059-39069

Issue Date

MARCH 2008

PARTS LIST

Aluminum wheel
(The illustration may differ from the actual wheel.)

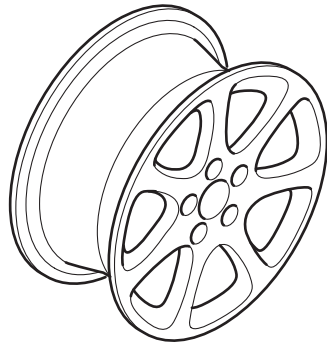

Center cap

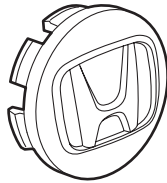

Grommet



TOOLS AND SUPPLIES REQUIRED

Ratchet
11 mm Socket
Torque wrench
Isopropyl alcohol
Shop towel
HDS (Honda Diagnostic System)
Snap-on TPMS sensor initializer tool

INSTALLATION

Customer Information: The information in this installation instruction is intended for use only by skilled technicians who have the proper tools, equipment, and training to correctly and safely add equipment to your vehicle. These procedures should not be attempted by “do-it-yourselfers.”

NOTE:

- This aluminum wheel is designed for use on vehicles with TPMS (Tire Pressure Monitoring System).
- See the Service Manual for tire replacement procedure and TPMS sensor installation procedure (paragraph of Tire Pressure Sensor Replacement).
- Illustrations are shown for reference purposes only.
- Install the correct size tire.
- Use a tire changer to remove and install the tires. Using a tire lever to remove and install the tires can damage to the tire, the wheel, and the TPMS sensor.
- The wheel nut torque is 108 N·m (80 lb-ft).
- The standard wheel nuts may not be used with the aluminum wheels. Replace them with the correct wheel nuts, which are sold separately.

for wheels with cap



for aluminum wheels



1. Remove the valve stem nut and washer, then remove the tire pressure sensor from the wheel.

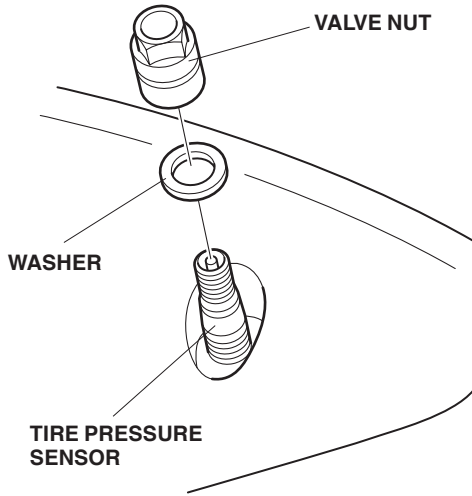

2. Remove and discard the grommet from the tire pressure sensor.

NOTE: The grommet might stay in the wheel; make sure you remove the valve stem grommet.

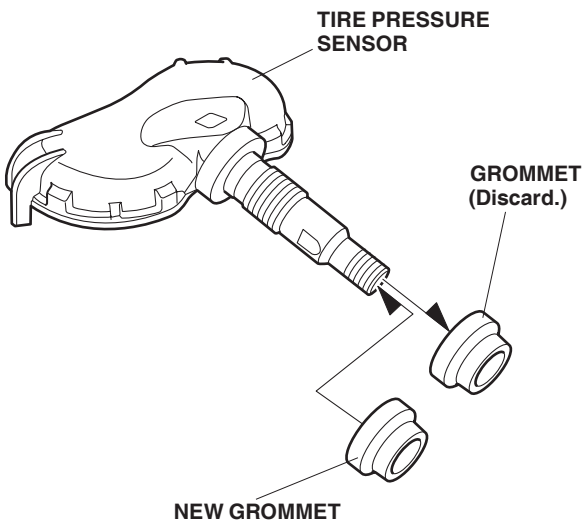

3. Install the new grommet onto the tire pressure sensor.
4. Clean the mating surface and the valve hole of the aluminum wheel.

5. Install the tire pressure sensor and the washer to the aluminum wheel, and loosely install the valve nut. Make sure the pressure sensor is resting on the wheel.

NOTE: Install the tire pressure sensor so that the sensor housing surface does not exceed the wheel protrusion.

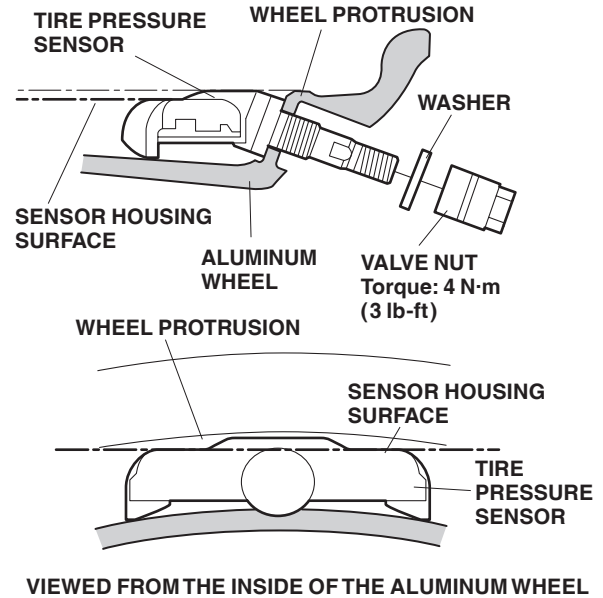

6. Tighten the valve nut to the specified torque while holding the tire pressure sensor toward the wheel.
Tightening torque: 4 N·m (3 lb-ft)

NOTE:

- Do not reuse the grommet that had been tightened, even one time, to the specified torque; otherwise, the valve stem may leak.
 - Do not use pneumatic or electric tools on the valve nut.
7. Install the tires according to the instructions in the Service Manual.
 8. Install the wheels on the vehicle and torque the wheel nuts to 108 N·m (80 lb-ft).

TIRE PRESSURE SENSOR LOCATIONS

- Using the HDS and the Snap-on TPMS sensor initializer tool, register the TPMS sensor locations in order of ①, ②, ③, and ④ according to "Tire Pressure Sensor Location" in the Service Manual.

