

**PARTS LIST**

**CD Changer Attachment:  
P/N 08B26-S5D-100**

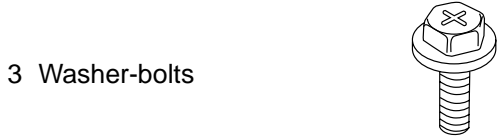

BUS cable

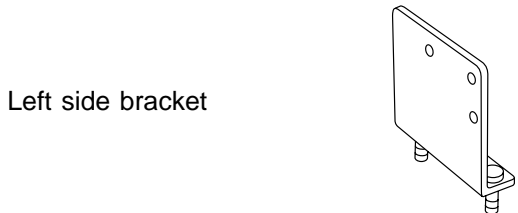
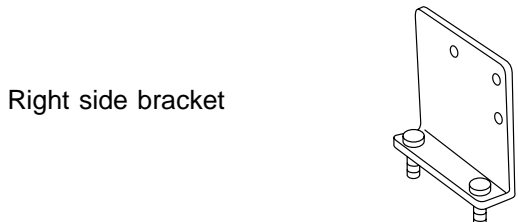
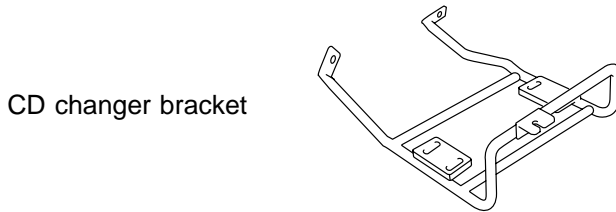
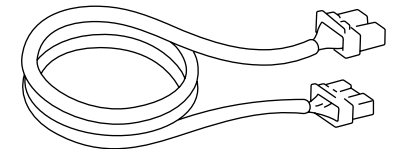

4 Washer screws



**CD Changer :  
P/N 08A26-1B1-100**

CD changer

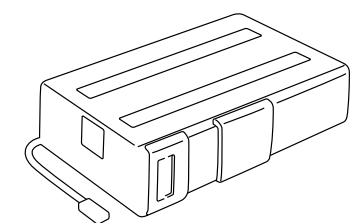

Owner's Manual

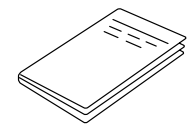

CD magazine

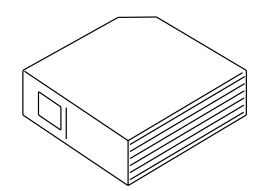

4 Washer-screws, 4 x 6 mm



Adhesive seal sheet

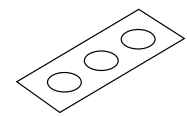

Locking covers

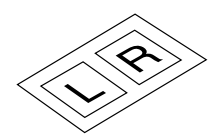

## TOOLS REQUIRED

Phillips screwdriver  
Flat-tip screwdriver  
Stubby Phillips screwdriver  
10 mm Combination wrench  
Clip remover  
8 mm and 10 mm Sockets  
Ratchet  
Small flat-tip screwdriver

### Illustration of the CD Changer Installed on the Vehicle

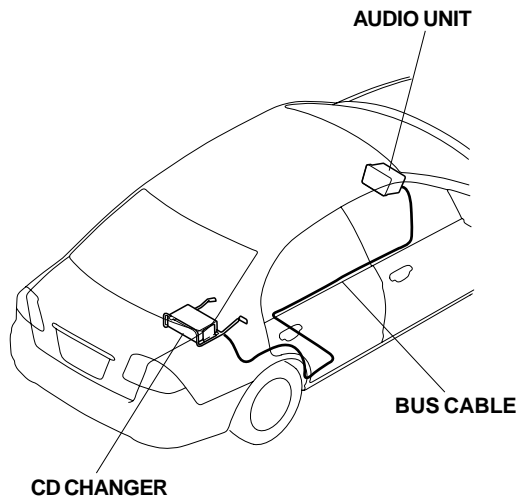

## INSTALLATION

**Customer Information:** The information in this installation instruction is intended for use only by skilled technicians who have the proper tools, equipment, and training to correctly and safely add equipment to your car. These procedures should not be attempted by "do-it-yourselfers."

1. Make sure you have the anti-theft code for the radio, then write down the frequencies for the preset buttons.
2. Disconnect the negative cable from the battery.

3. Open the trunk lid, and remove the weatherstrip in the area shown. Remove the four clips, then pull out on the right trunk side trim panel in the direction shown.

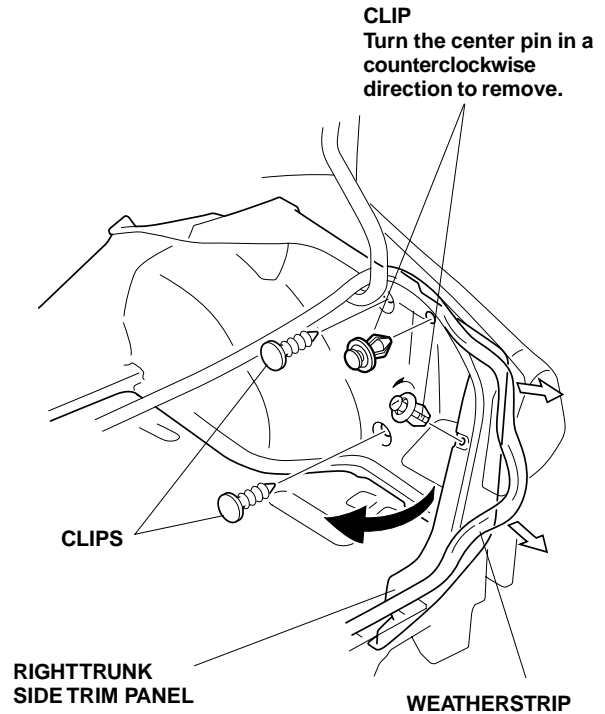

4. Inside the passenger's compartment, remove the rear seat cushion by removing the bolt and releasing the two hooks.

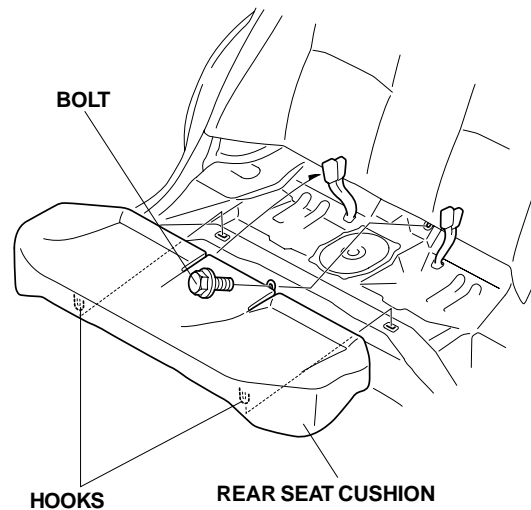

- Remove the right seat side bolster. Removing the bolt, pull the hook toward the rear of the car, then pull the bolster out toward you in the direction shown.

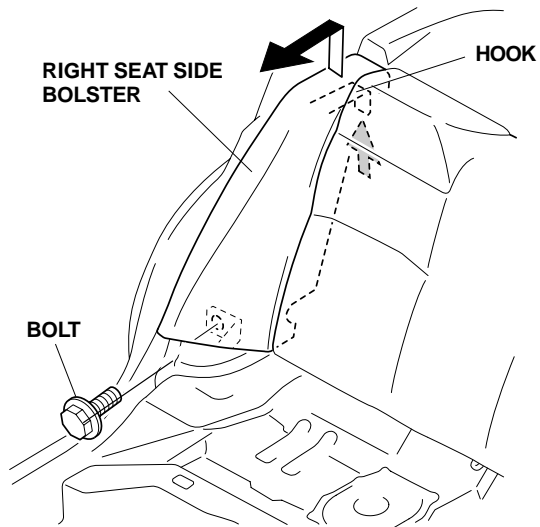

- Pry up on the six retaining tabs, and remove the B-pillar lower trim panel.

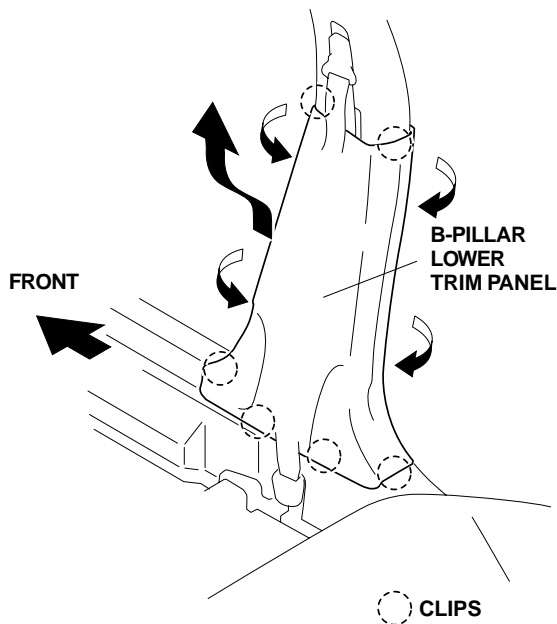

- Remove the four clips, release the two retaining tabs that fasten the right seat side trim, and remove the trim. Take care not to damage the clips.

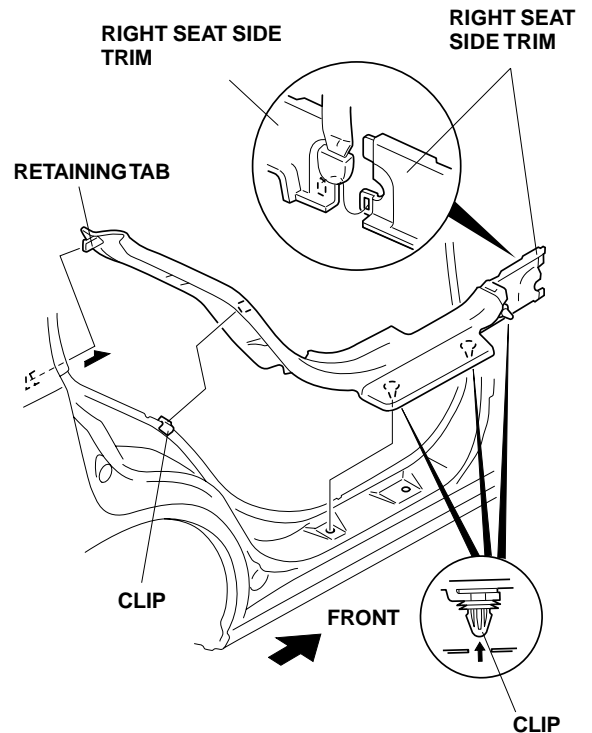

- Pull up on the parking brake lever, then remove the console box (nine clips).

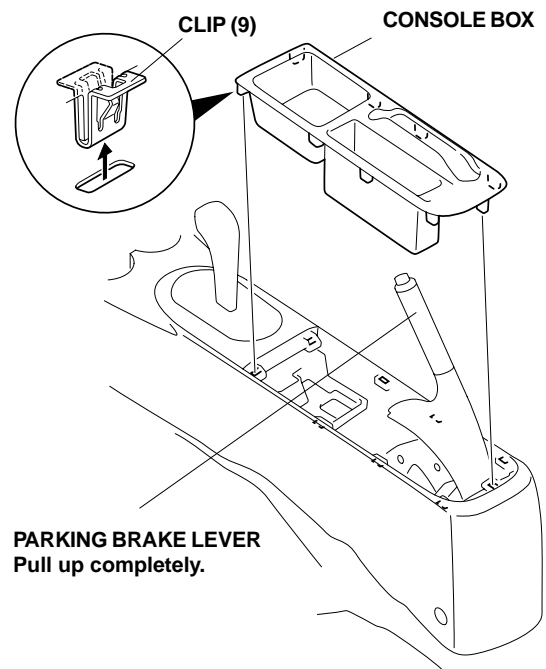

9. Remove the two self-tapping screws, two screws, and two clips that fasten the center console and remove the console:
  - Place the shift lever in the Neutral position.
  - On M/T model, remove the shift knob from the lever by holding the plastic section above the boot down firmly with one hand and turning the knob counterclockwise.
  - If equipped with an optional armrest, remove the console after reclining the seat-back.

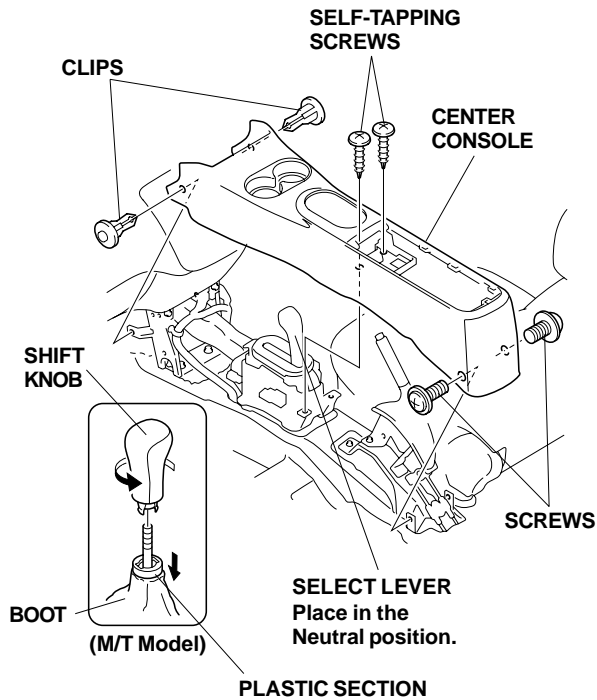

10. Remove the dashboard center lower cover.

**Without a Cigarette Lighter and Ashtray:**

- With the parking brake applied, place the gear shift lever in the Neutral position.
- Gently pry out on the dashboard center lower cover to release the six retaining clips.
- Unplug the accessory power socket connector, and remove the dashboard center lower cover. If equipped, unplug the fog light harness.

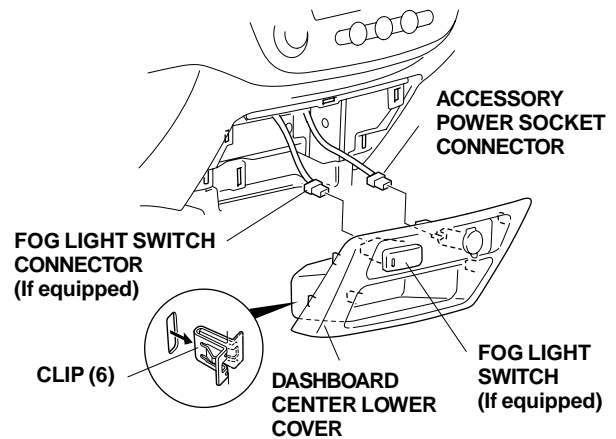

**With a Cigarette Lighter and Ashtray:**

- With the parking brake applied, place the gear shift lever in the Neutral position.
- Remove the ashtray.
- Inside the ashtray opening, remove the one self-tapping screw that secures the dashboard center lower cover.
- Gently pry out on the lower cover to release the six retaining clips.
- Unplug the cigarette lighter harness, and the illumination lamp, then remove the lower cover. If equipped, unplug the fog light harness.

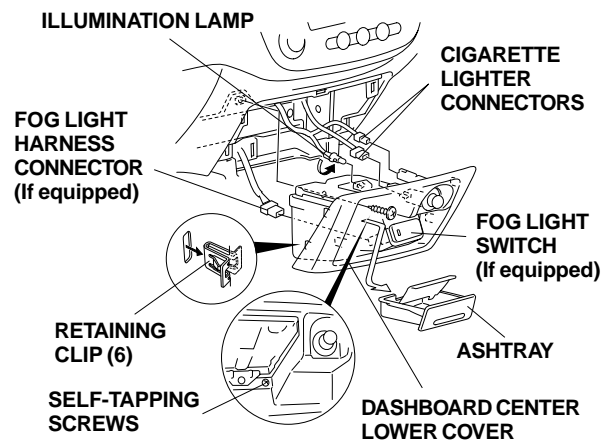

11. Remove the center panel:

- Remove the two bolts from the bottom of the center panel.
- Reach through the bottom opening, and push out on the center panel bracket to release the nine retaining clips.
- Unplug the five connectors and the antenna lead, then remove the center panel.

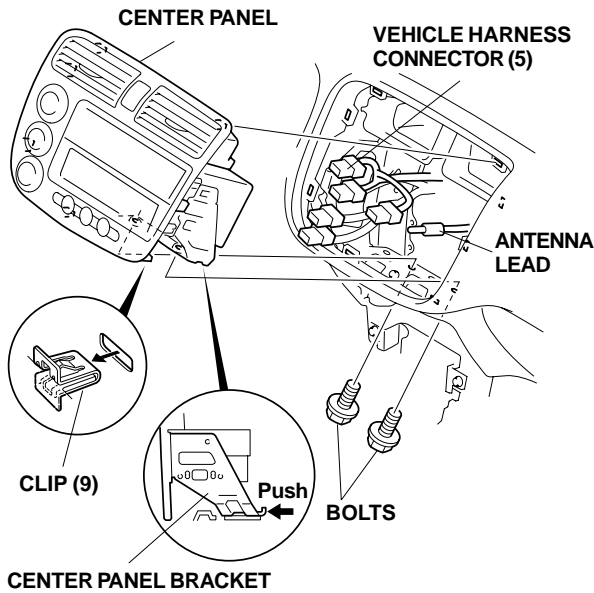

**Installing the CD Changer**

12. Carefully unpack the CD changer. Remove the three shipping clips, and discard the shipping cover. Save the shipping clips for your customer in the event the unit needs to be serviced.
13. Install an adhesive seal (included in the CD Changer) over each of the three shipping clip holes.

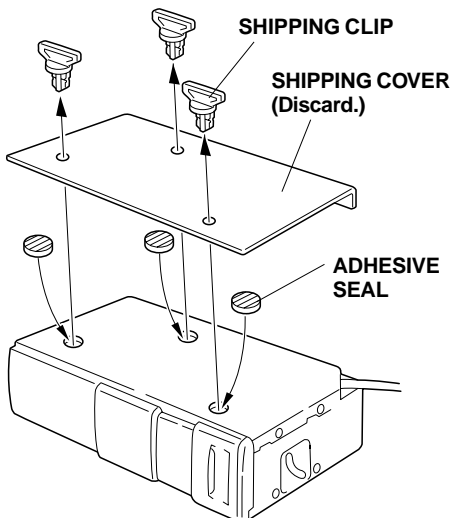

14. Visually check the position of the spring adjusting pins on both sides of the CD changer. If both of the spring adjusting pins are not in the horizontal (H) position, move the pins to the horizontal position with a small flat-tip screwdriver.

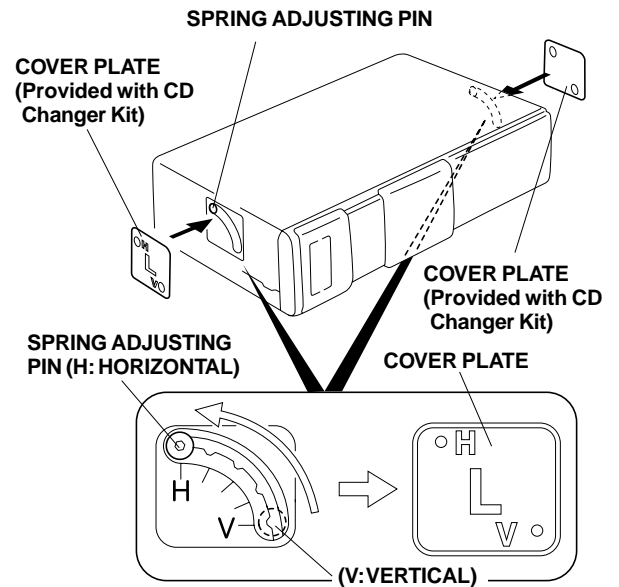

15. Remove the adhesive backings from the "L" and "R" locking covers, and attach them to the side of the CD changer. Align the two diagonally opposite holes with the H and V positions.
16. Slide the three clip nuts onto the rear shelf through the holes in the shelf.

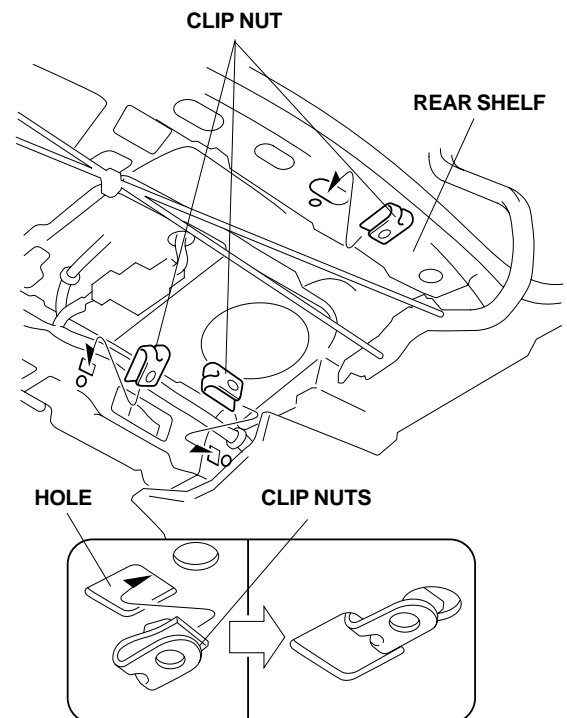

17. Position the CD changer bracket on the clip nuts you just installed, and install the three washer-bolts. Adjust the bracket so that it is level, then tighten the bolts.

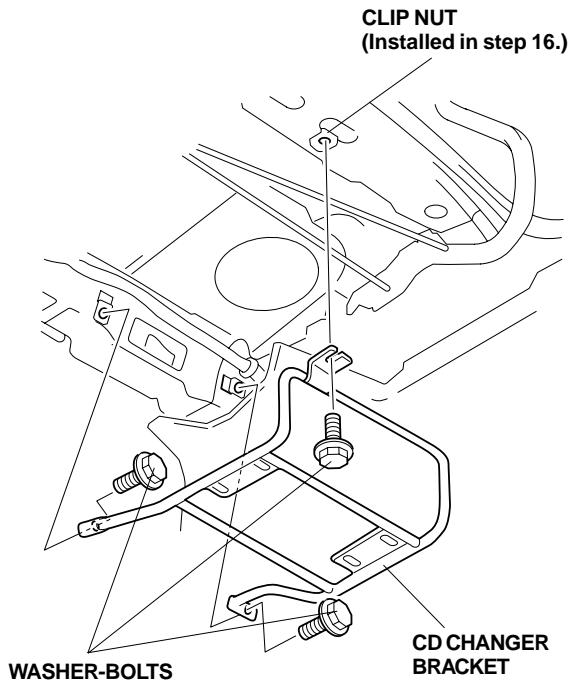

18. Position the side brackets on the CD changer, and install the four 4 x 6 mm washer-screws provided with the CD Changer Kit. Note the direction of the side brackets. The extra hole in each of the brackets should face the front of the CD changer. Tighten the washer-screws securely.

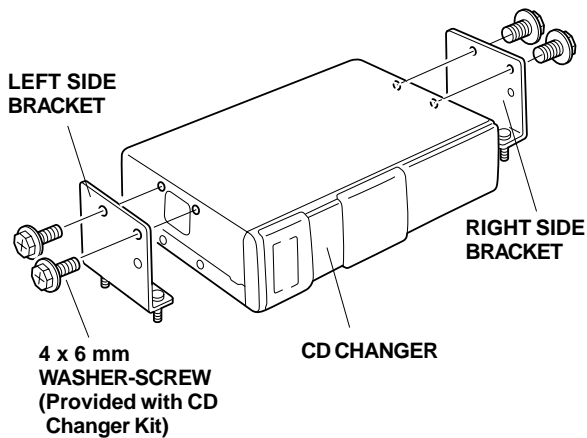

19. Position the CD changer on the CD changer bracket, and install a cap nut on the end of each stud extending from the CD changer.

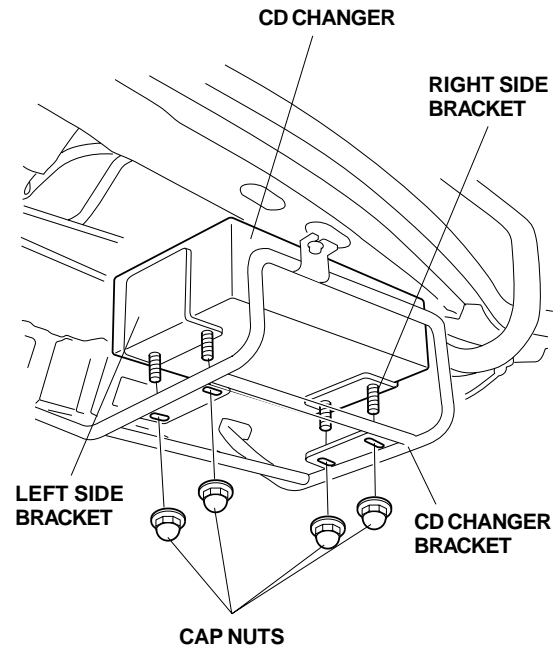

### Routing the BUS Cable

20. Connect the BUS cable connector to the connector from the CD changer.

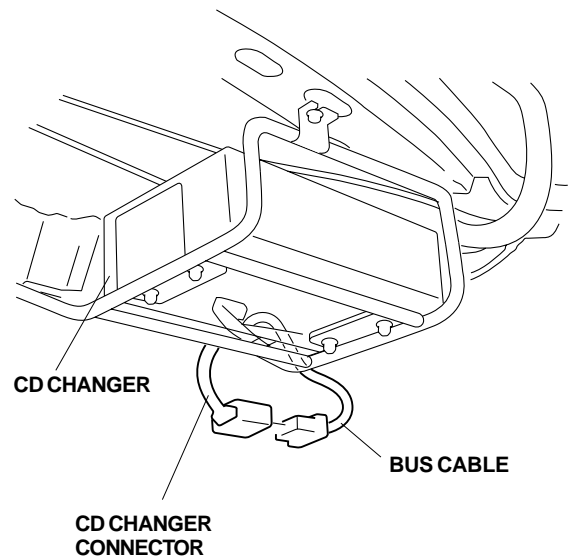

21. Secure the connector and BUS cable to the CD changer bracket with three wire ties in the areas shown.

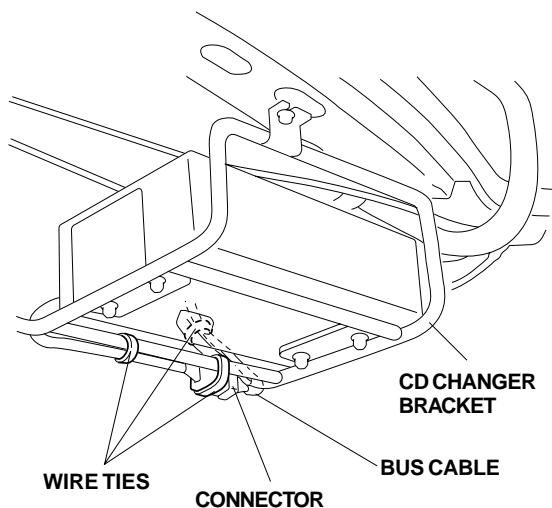

22. Inside the trunk, route the other end of the BUS cable into the passenger's compartment through the hole in the panel.

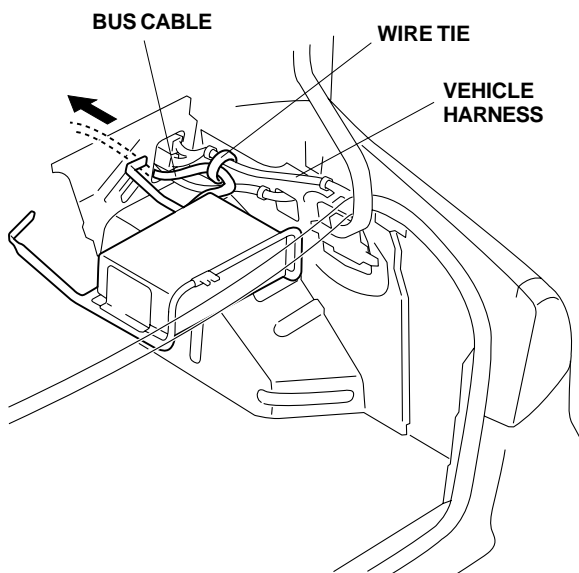

23. Secure the BUS cable to the vehicle harness with one wire tie in the area shown.

24. Remove the clip, and turn over the carpet as shown. Continue routing the BUS cable, then secure it to the vehicle harness with five wire ties in the areas shown.

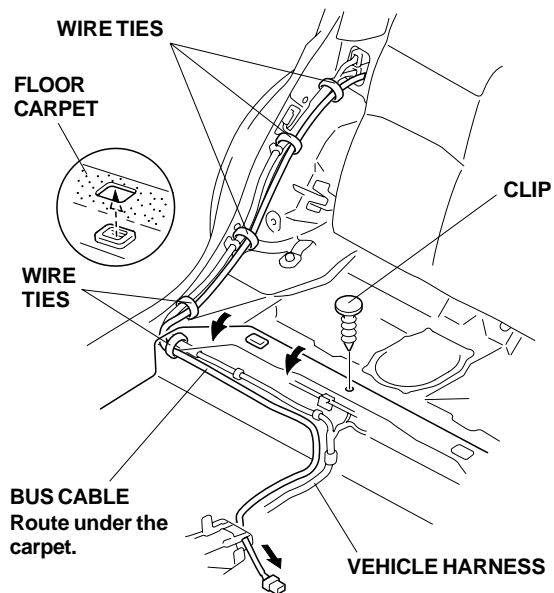

25. Route the BUS cable forward under the parking brake lever base and to the right front console frame along the vehicle harness.

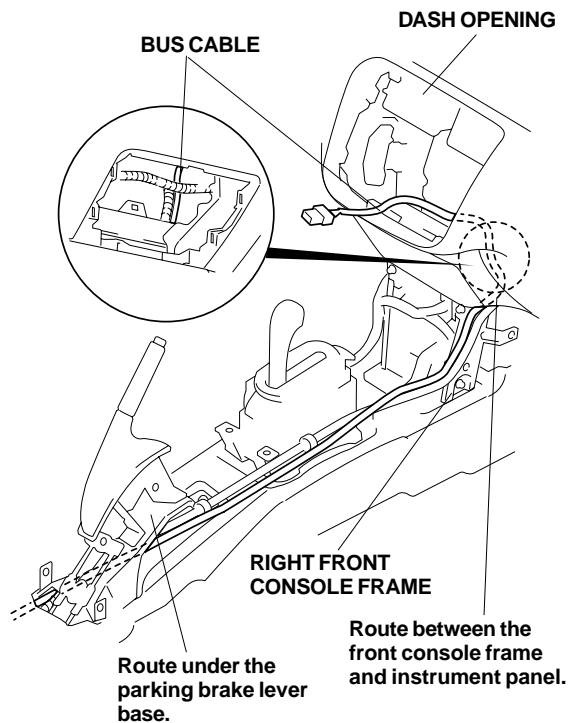

26. Route the BUS cable connector through the clearance between the right front console frame and dashboard and out through the dash opening.

27. Pull the vehicle harness 20-pin connector (blue) and BUS cable connector out through the dash opening; then secure them to the vehicle harness with one wire tie in the area shown.

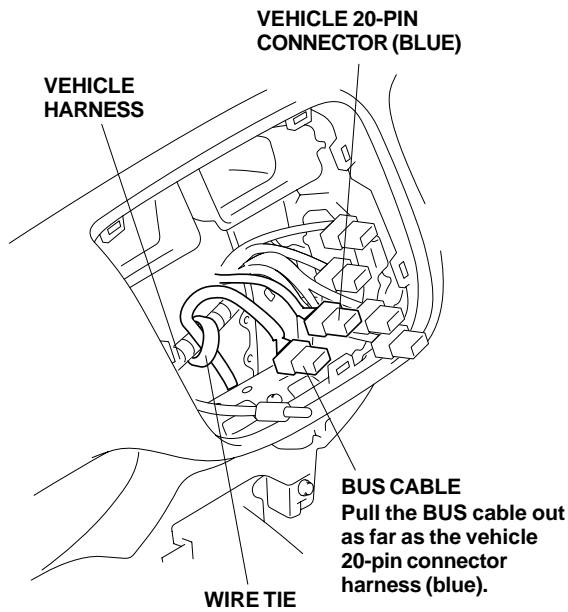

28. Secure the BUS cable to the vehicle harness with the five wire ties in the areas shown.

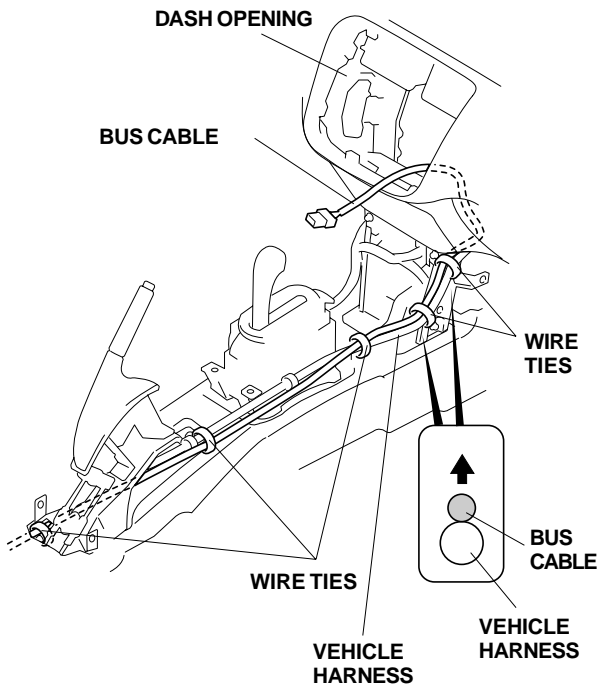

29. Secure the BUS cable to the vehicle harness with one wire tie in the area shown.

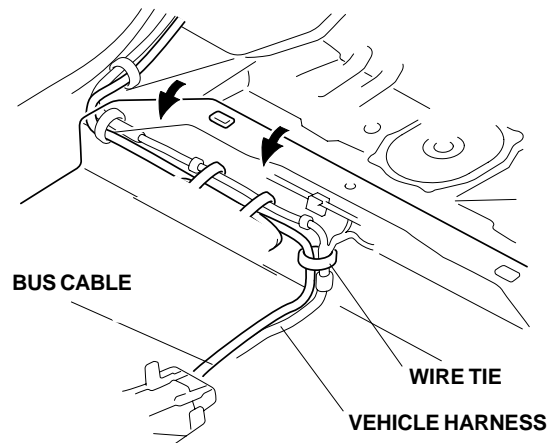

30. Bundle up the excess cable, and secure it to the CD changer bracket with two wire ties.

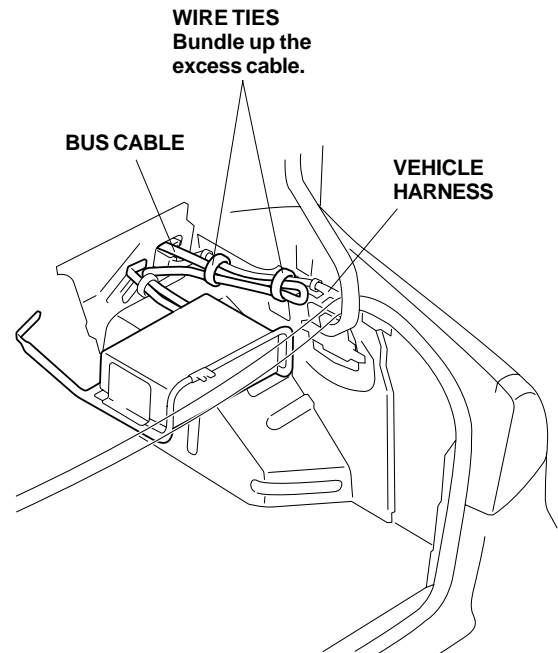



31. Plug the BUS cable connector, the vehicle 20-pin connector (blue), and the antenna lead into the rear of the audio unit.

**When Radio and Pocket Are Installed:**

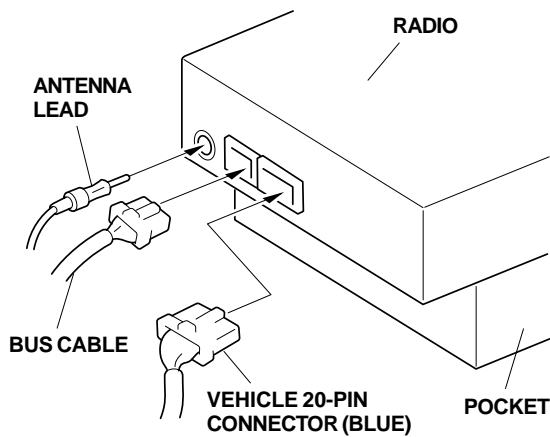

**When Radio and Cassette Player Are Installed:**

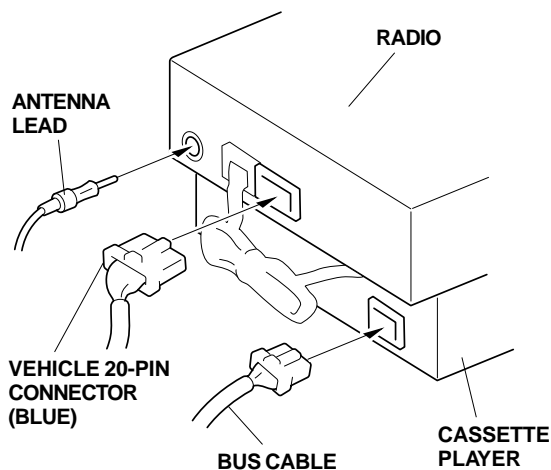

32. Connect the four vehicle connectors to the center panel, and reinstall the center panel.

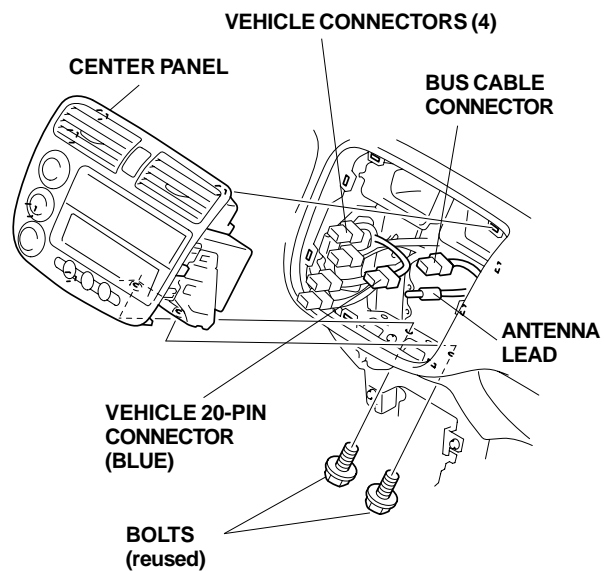

33. Check that all wire harnesses are routed properly and all connectors are plugged in.
34. Reconnect the negative cable to the battery.
35. Enter the radio anti-theft code and reset the customer's radio station presets.
36. Reset the clock.
37. Test the operation of the accessory socket/cigarette lighter.
38. Check the operation of the CD changer as described in the Owner's Manual supplied.
39. Reinstall all removed parts. Be sure that all retaining clips and tabs are securely fastened.
40. Put the CD changer Owner's Manual and the shipping clips (removed in step 12) in the glove box for your customer.