



INSTALLATION INSTRUCTIONS

Accessory

ENGINE BLOCK HEATER
P/N 08T44-S5B-100

Application

CR-V

Publications No.

All 26122

Issue Date

SEP 2003

PARTS LIST

Engine block heater

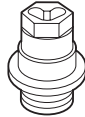

Aluminum washer



Heater harness

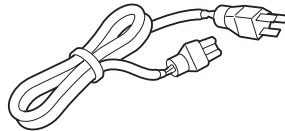

Protective cap

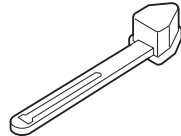

20 Long wire ties

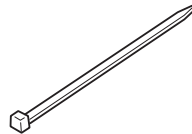

TOOLS AND SUPPLIES REQUIRED

Phillips screwdriver

Ratchet

24 mm Socket

Hexagon wrench

Torque wrench

Diagonal cutters

Coolant (Honda All Season Antifreeze/Coolant
Type 2 only)

8 mm Allen socket

INSTALLATION

Customer Information: The information in this installation instruction is intended for use only by skilled technicians who have the proper tools, equipment, and training to correctly and safely add equipment to your vehicle. These procedures should not be attempted by "do-it-yourselfers."

NOTE:

- Always use Honda All Season Antifreeze/Coolant Type 2. Using a non-Honda coolant can result in corrosion, causing the cooling system to malfunction or fail.
- To avoid burning out the element, do not operate the engine block heater before it is installed in the vehicle or before you add coolant.

1. Allow the engine, and all cooling system components, to cool down.
2. Place a clean drain pan under the radiator drain plug, then remove the drain plug from the bottom of the radiator to drain the coolant. Remove the radiator cap to increase the flow.

NOTICE Radiator coolant will damage paint. Quickly rinse any spilled coolant from painted surfaces.

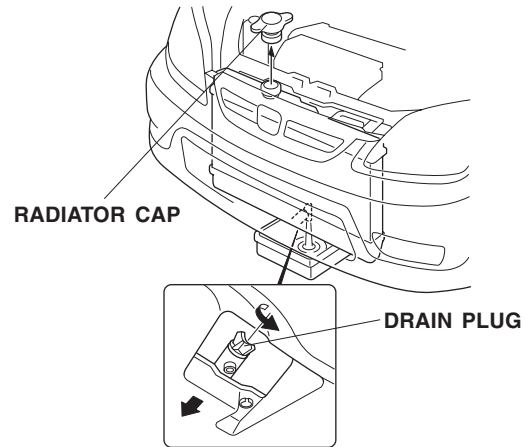

3. Remove the radiator cover (one bolt and seven clips).

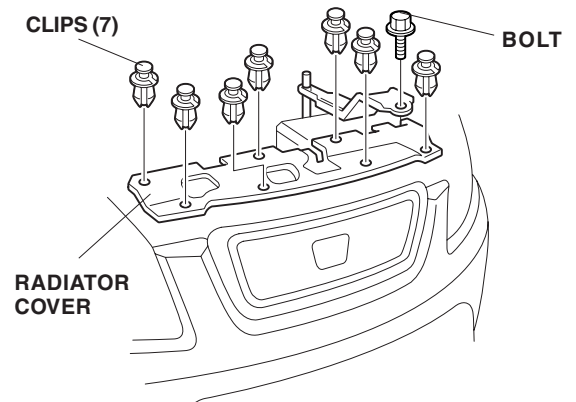

- Remove the drain plug with the washer from the rear of the engine block on the rear side near the oil filter. Coolant remaining in the engine jackets will flow out of the plug hole when the drain plug is removed. Retain the drain plug in case the engine block heater is removed.

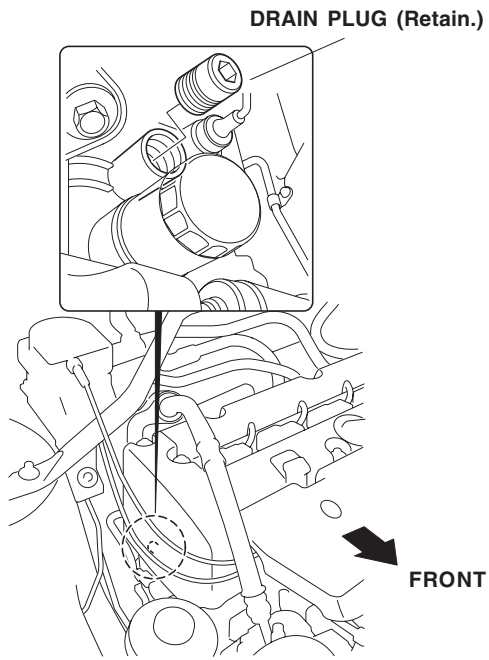

- Install the engine block heater with the aluminum washer into the bolt hole using a 24 mm socket. Torque the engine block heater to 60 N·m (44 lb-ft).

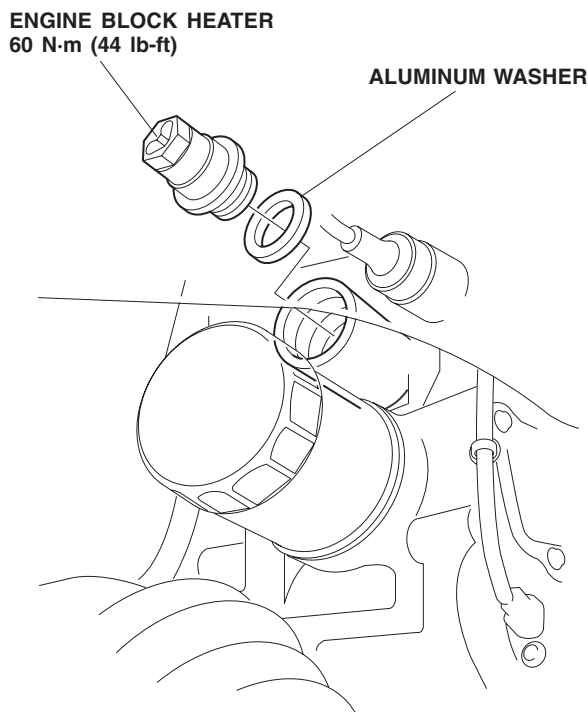

- Plug the connector of the heater harness into the engine block heater, and route the heater harness over the engine. Secure the heater harness to the vehicle harness with one wire tie in the area shown.

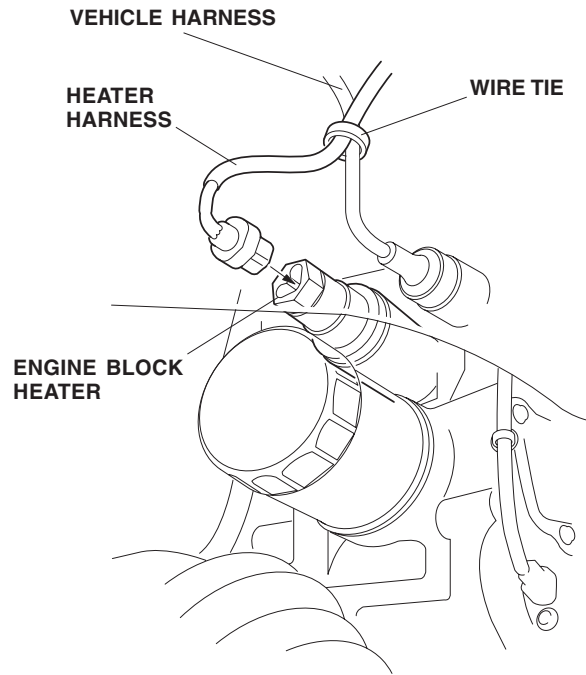

- Route the heater harness along the vehicle harness, and secure the heater harness to the vehicle harness with the three wire ties.

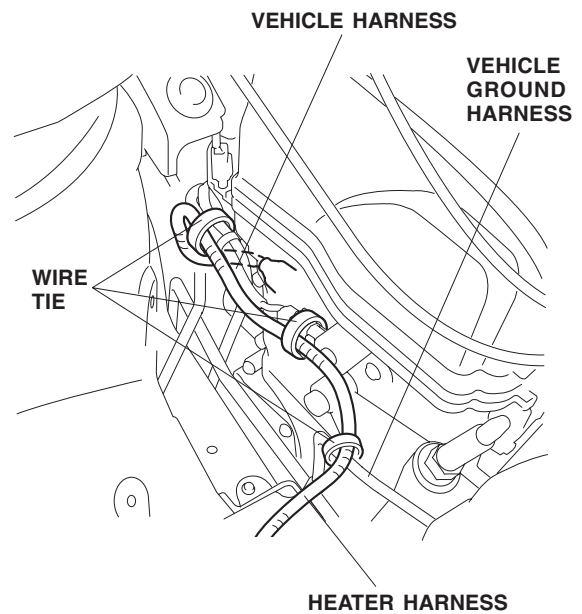

- Continue routing the heater harness toward the right headlight, and secure the heater harness to the holes in the panels with the two wire ties.

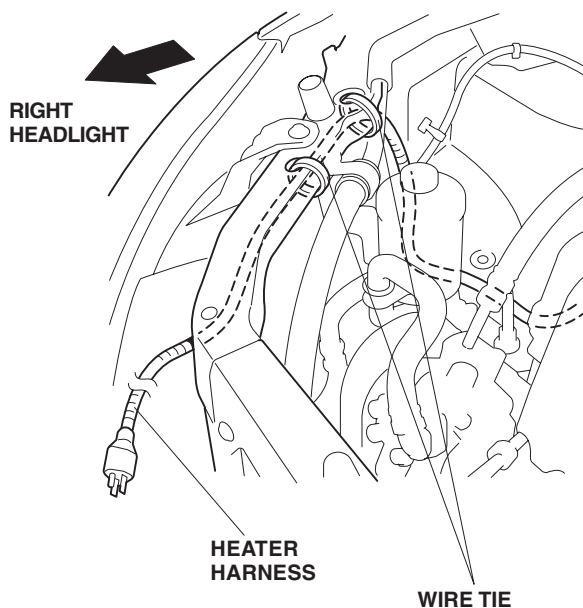

- Continue routing the heater harness alongside the radiator bracket to the front bumper grille.
- Secure the heater harness to the radiator bracket with the one wire tie.

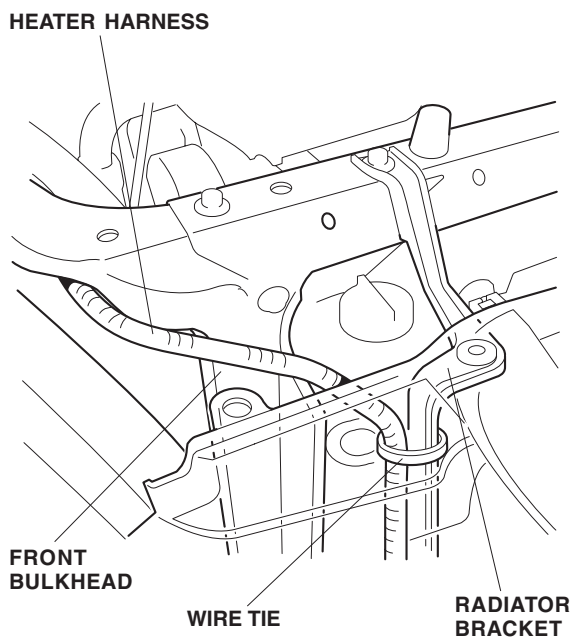

- Secure the heater harness to the bumper grille with the four wire ties.

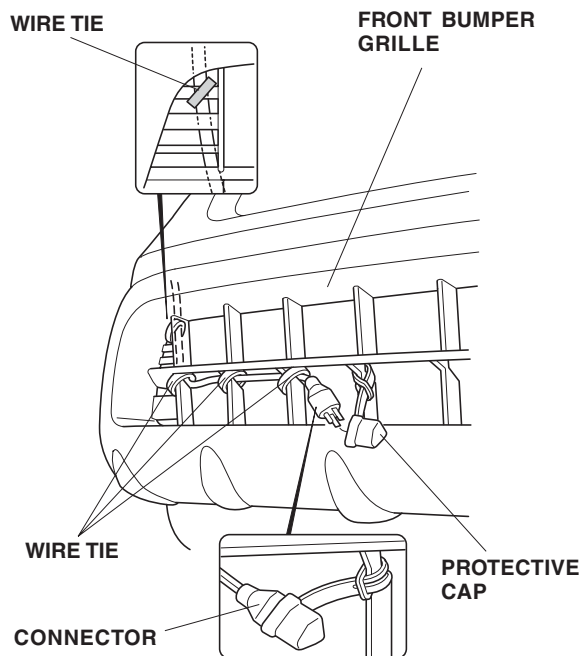

- Attach the protective cap to the grille, and plug the connector of the heater harness into the protective cap.
 - Reinstall the radiator drain plug.
 - Fill the system with the recommended coolant. Follow the instructions in the service manual.
 - Check the coolant reservoir for the correct level and signs of leakage. Repair as necessary.
 - Check that the heater harness is routed properly and all connectors are plugged in.
 - Put the drain plug (removed in step 4) in the glove box.
- NOTE:** Whenever the battery is disconnected, the driver's window AUTO function is disabled.
- Start the engine. Push down on the driver's window switch until the window is fully open.
 - Pull up on the driver's window switch to close the window completely, then hold the switch for 2 seconds or more.
 - Test the window AUTO function.