



INSTALLATION INSTRUCTIONS

Accessory

**FOG LIGHTS
P/N 08V31-S9A-115**

Application

2005 CR-V

Publications No.

All 27176-28932

Issue Date

FEB 2005

PARTS LIST

Left fog light

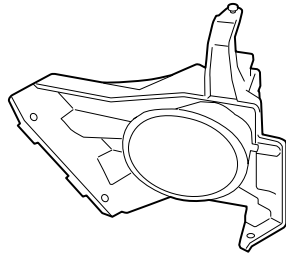

Right fog light

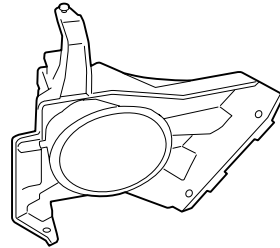

Fog light harness

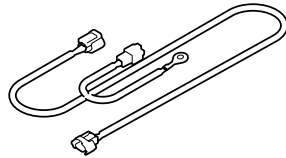

Switch harness

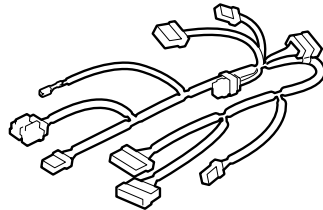

Fog light switch

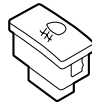

Relay

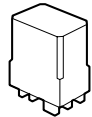

Fuse label

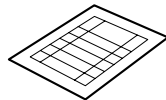

25 Wire ties

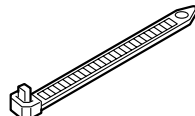

6 Washer-bolts



6 Spring nuts



Harness bracket

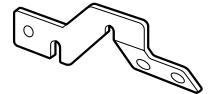

2 Wire ties with clip

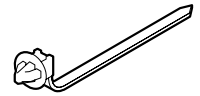

Left trim

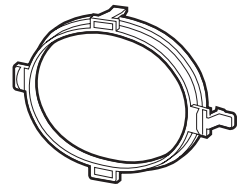

Right trim

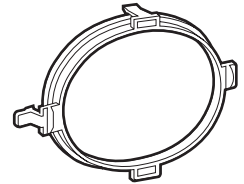

EPT sealer

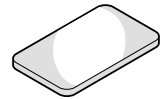

TOOL AND SUPPLIES REQUIRED

Phillips screwdriver

Flat-tip screwdriver

Ratchet

10 mm and 14 mm sockets

File

Torque wrench

Hacksaw blade

Duct tape

Illustration of the Fog Lights Installed on the Vehicle

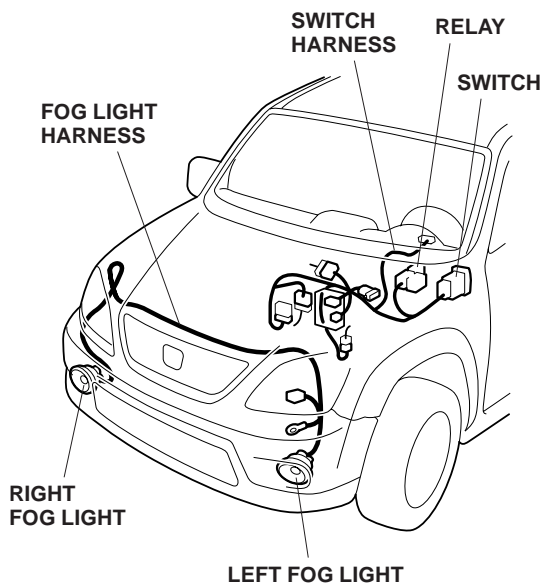

INSTALLATION

Customer Information: The information in this installation instruction is intended for use only by skilled technicians who have the proper tools, equipment, and training to correctly and safely add equipment to your vehicle. These procedures should not be attempted by "do-it-yourselfers."

NOTE: These installation instruction show the left fog light begin installed. The same procedure applies to installing the right fog light.

1. Make sure you have the anti-theft code for the radio, then write down the radio station presets.
2. Disconnect the negative cable from the battery.

Installing the Fog Light

3. Open the hood. Remove the radiator cover (seven clips and one bolt).

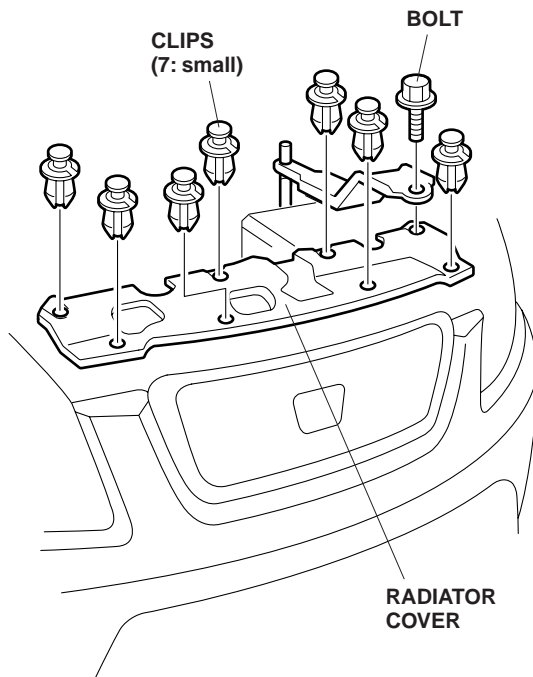

4. Remove the eight clips and four self-tapping screws that fasten the front bumper. With an assistant holding the bumper, remove the front bumper.

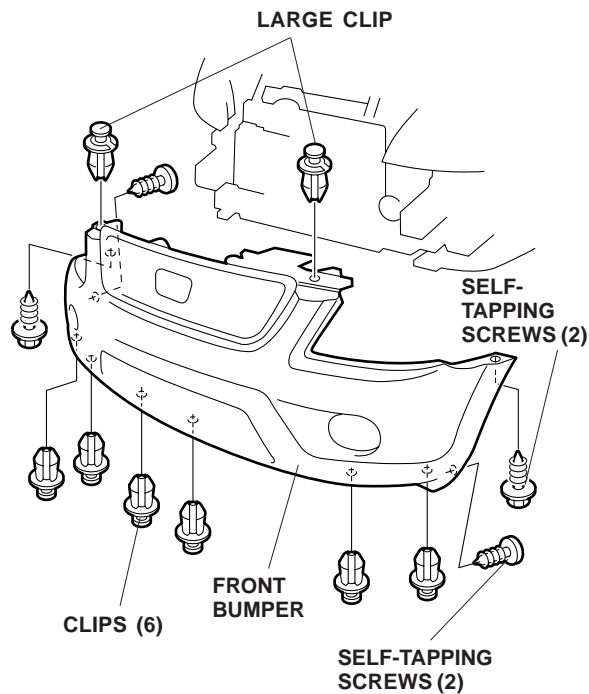

- Using duct tape, mask the bumper around the fog light opening.

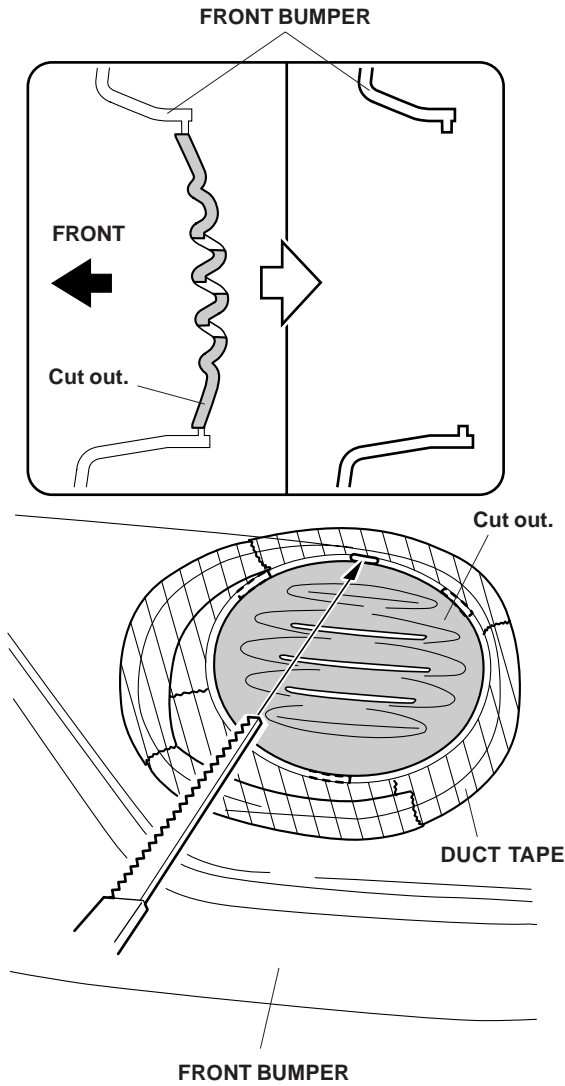

- Using a hacksaw blade, slowly and carefully cut out the fog light opening. Be sure to cut the opening as round as possible, and do not damage the bumper. Remove any burrs from the edges of the fog light opening with a file.

- Get the left trim. Using the tab (marked "L") on the left trim as a reference, attach the left trim to the bumper with the "L" between the bosses on the front bumper.

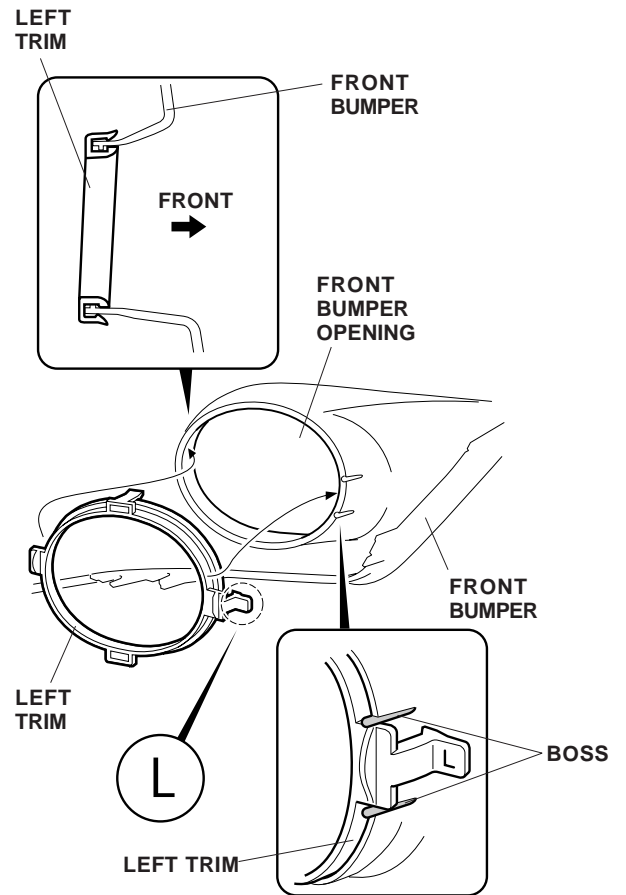

- Install the three spring nuts on the front bumper rib.

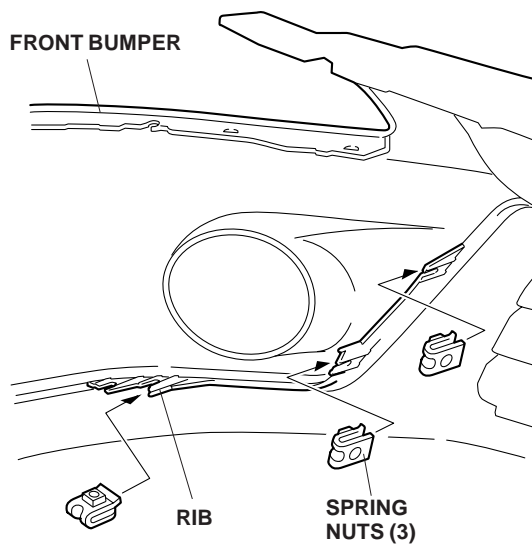

- Fit the pin from the left fog light into the recess in the front bumper. Position the left fog light over the three holes in the spring nuts, and install the three washer-bolts.

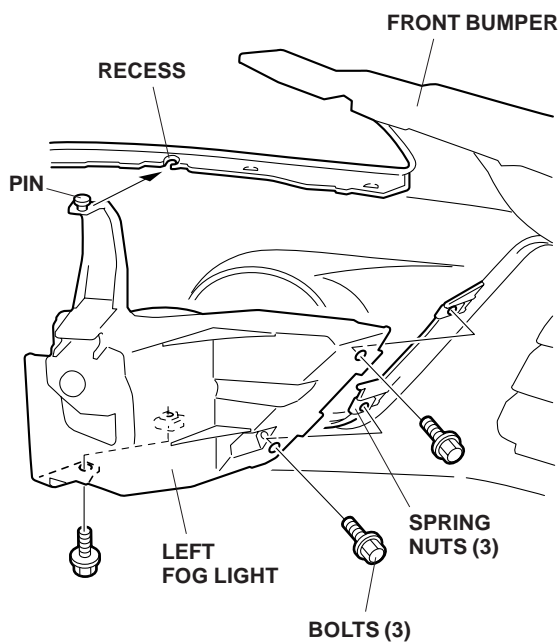

- Repeat steps 5 through 9 to install the fog light on the right side of the vehicle.

Routing the Fog Light Harness

- Behind the left headlight, locate the fog light 1-pin connector blue-taped to the vehicle harness. Remove the blue tape to free the connector.

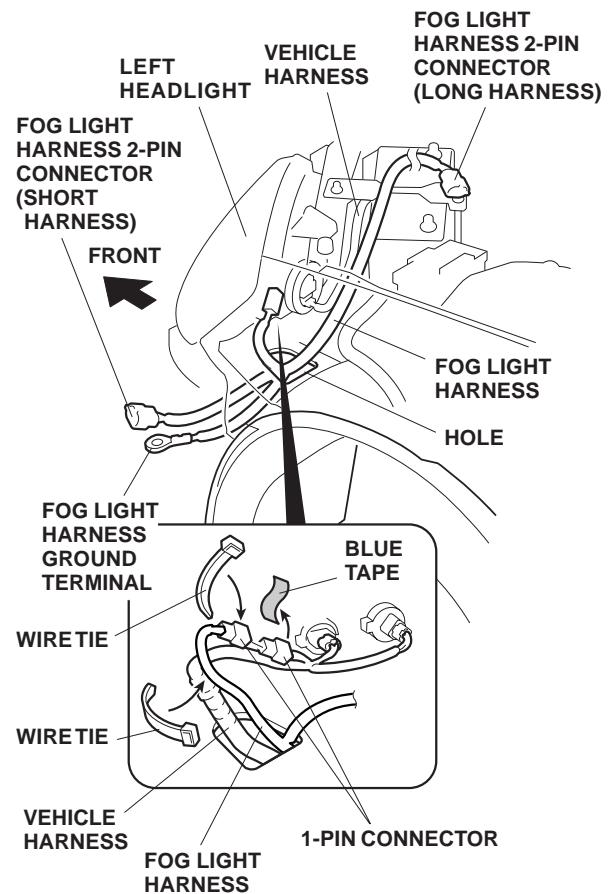

- Get the fog light harness. Plug the fog light harness 1-pin connector into the vehicle harness 1-pin connector. Secure the 1-pin connector to the vehicle harness with two wire ties.
- Route the fog light harness 2-pin connector (short harness), and the ground connector harness through the hole under the left headlight.
- Route the fog light harness 2-pin connector (the one with a long harness) to the right along the vehicle harness.

15. Locate and remove the vehicle ground bolt. Attach the fog light harness ground terminal to this ground bolt, and tighten the bolt securely.

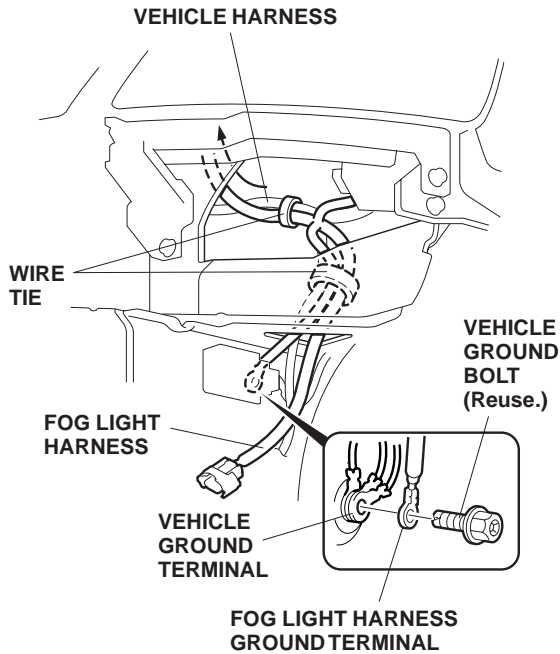

16. Secure the fog light harness to the vehicle harness with two wire ties in the areas shown.
17. Route the fog light harness 2-pin connector along the vehicle harness, secure the fog light harness to the vehicle harness with two wire ties in the areas shown.

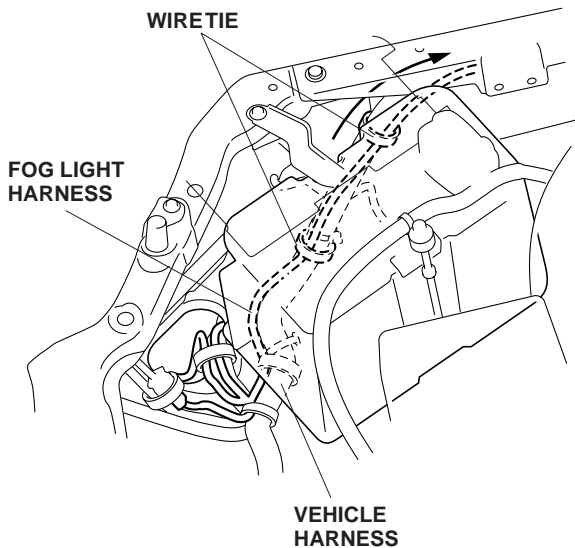

18. Attach two wire ties with clip to the fog light harness at the green-taped positions, then push the clip into the holes in the harness bracket.

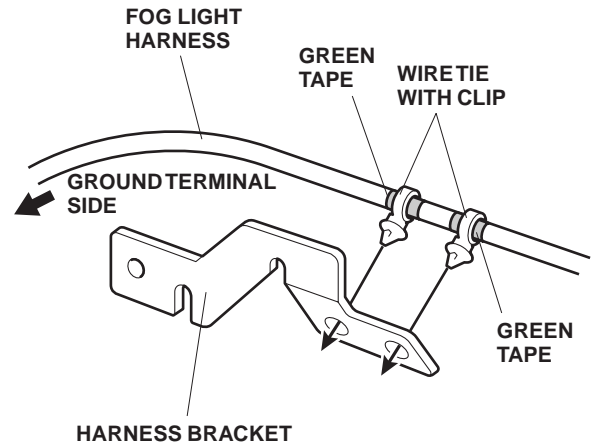

19. Remove two bolts that secure the air intake. Insert the harness bracket between the air intake and the bulkhead, then secure it with the two bolts. Secure the fog light harness to the vehicle harness with two wire ties.

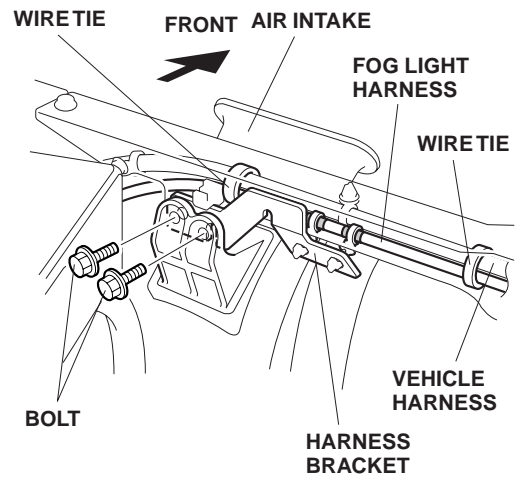

20. Route the fog light harness along the vehicle harness through the hole in the body panel. Secure the fog light harness to the vehicle harness, and to the bulkhead upper frame with the six wire ties in the areas shown.

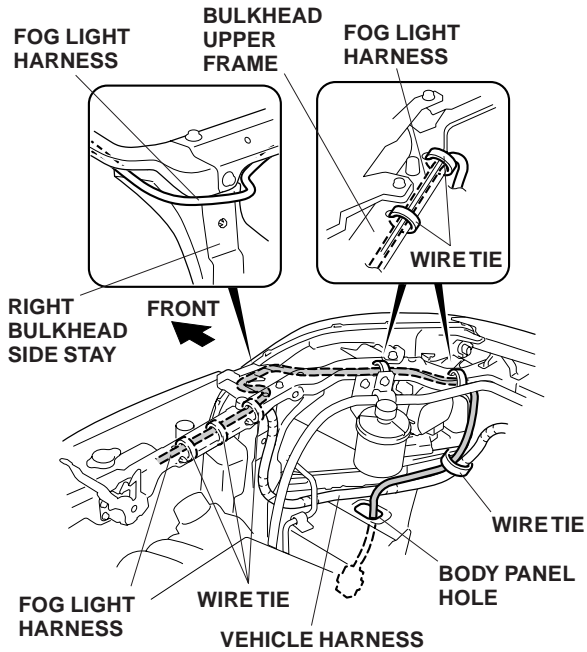

21. Secure the fog light harness to the vehicle ground harness with one wire tie. Do not secure the fog light harness to the SRS harness.

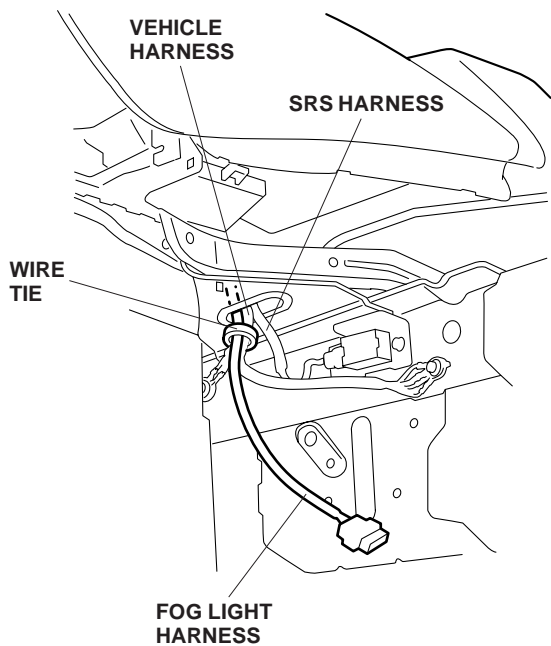

22. With an assistant holding the bumper, connect the two fog light harness 2-pin connectors to the left and right fog lights, then reinstall the front bumper. Do not fasten the inner fender (four clips and two self-tapping screws) to the front bumper until after the fog light aiming adjustment.

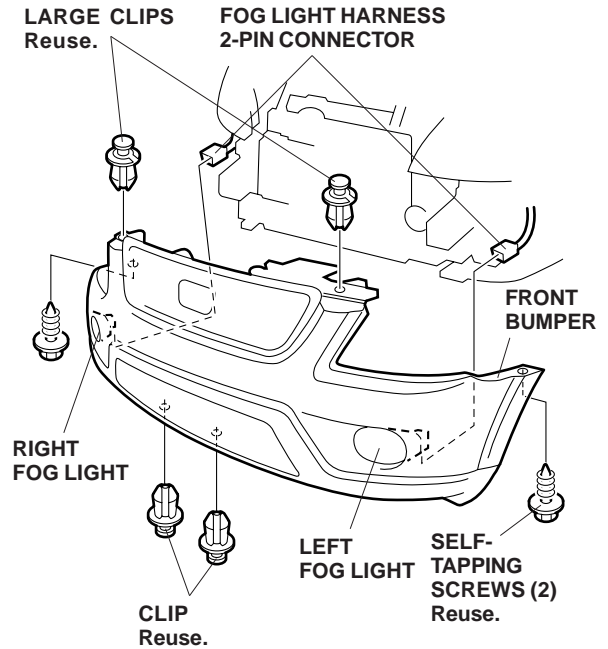

Routing the Switch Harness

23. Remove the driver's dashboard under cover by turning the knob clockwise, and releasing one clip.

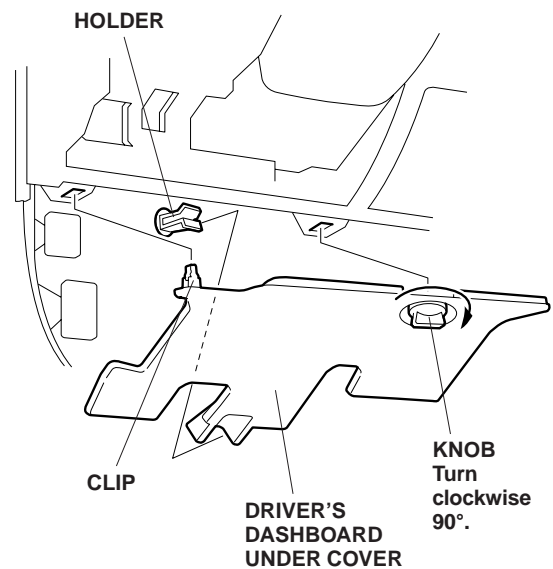

24. Remove the driver's dashboard lower cover:
- Remove the fuse box lid, and open the pocket.
 - Remove the two self-tapping screws.
 - Gently pull out on the driver's dashboard lower cover to release the eight clips. If equipped, unplug the vehicle connector and remove the lower cover.

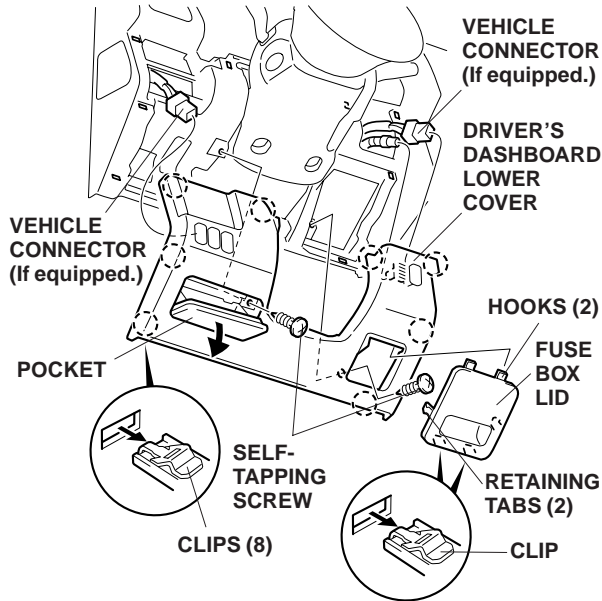

25. Lower the steering wheel tilt lever. Remove the upper and lower steering column covers. (two self-tapping screws, one screw, and six tabs). Gently push on the six retaining tabs, and separate the two steering column covers.

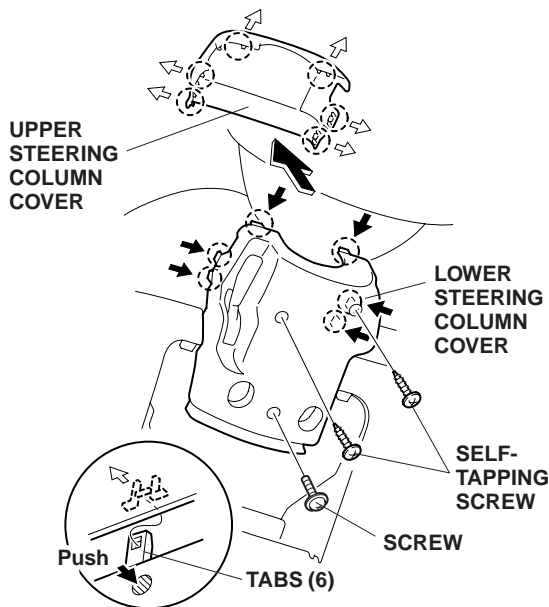

26. Remove the passenger's dashboard under cover (release the three clips and two pins).

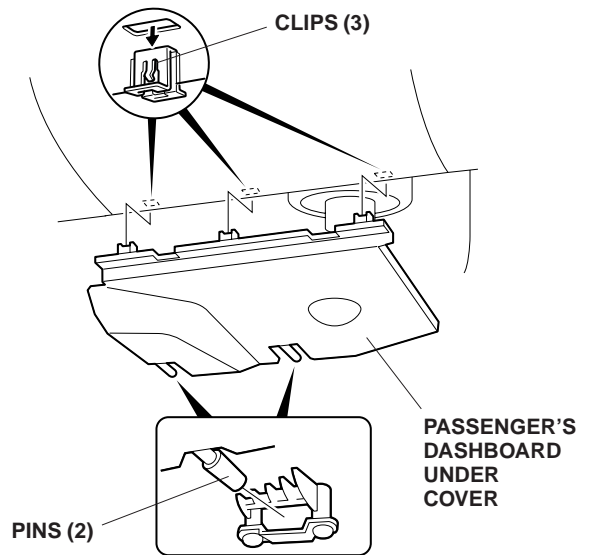

27. Open the dashboard pocket lid. Remove the lid by releasing the two retaining clips and two retaining tabs, then remove the dashboard pocket (one self-tapping screw, then pull out to release the one clip and three retaining tabs). Unplug the vehicle connector.

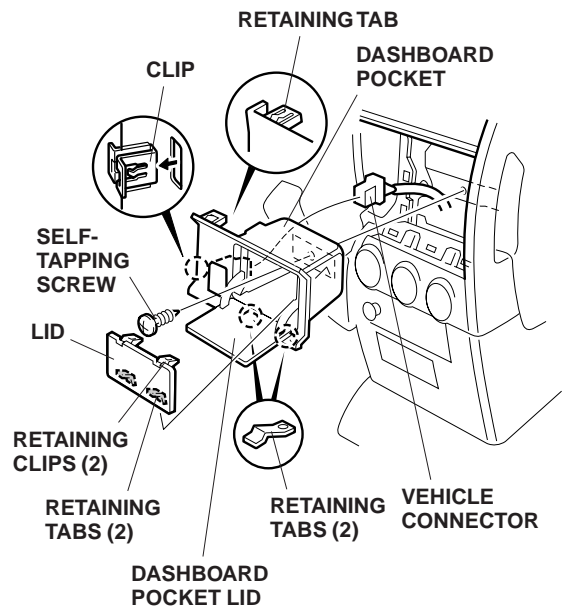

28. Remove two self-tapping screws that fasten the heater A/C control panel to the dashboard. Pull the heater A/C control panel out toward you to release the four clips. Unplug the vehicle connector, and remove the heater A/C control panel.

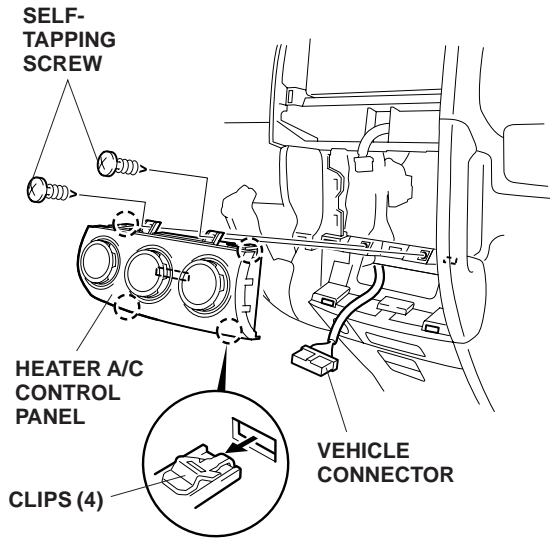

29. On A/T vehicles only, remove the two clips and six self-tapping screws, and pull the dashboard center lower cover out toward you to release the six clips. Unplug the vehicle 2-pin connector from the accessory socket, and remove the cover.

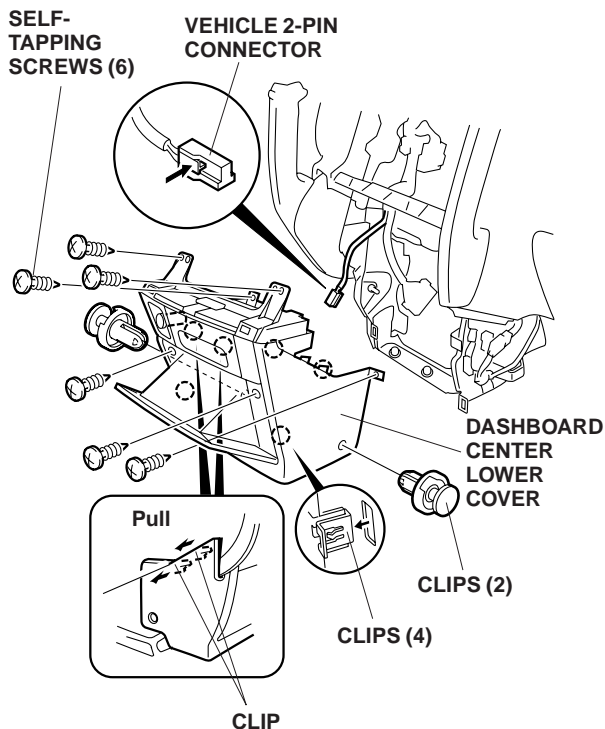

30. On M/T vehicles only, remove the four seat track end covers from the driver's seat, then remove the four bolts that secure the seat.

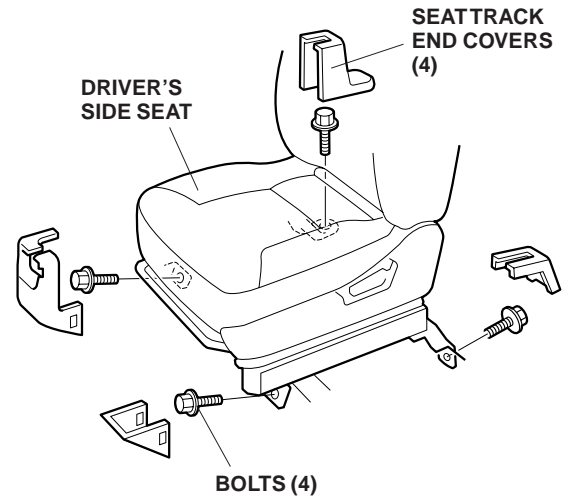

31. On M/T vehicle only, pull the shift boot down while holding the plastic clip. Remove the shift knob from the shift lever by turning it counterclockwise.

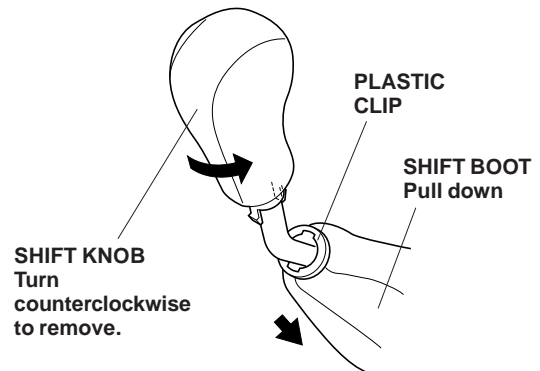

32. On M/T vehicle only, remove the two side covers (four tabs) from the center console.

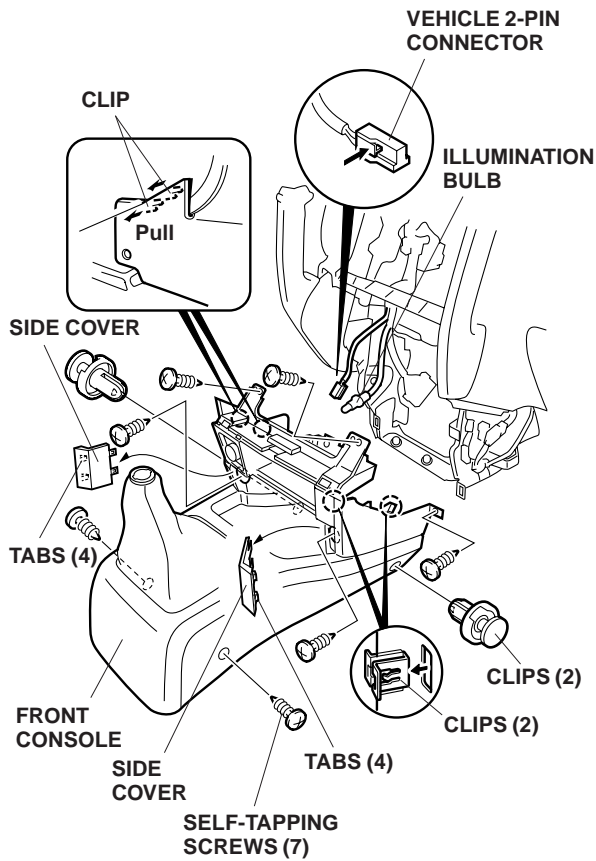

33. On M/T vehicle only, remove the two clips and seven self-tapping screws, and pull the front console out toward you to release four clips. Unplug the 2-pin connector from the accessory socket, and remove the front console.

34. Route the switch harness 5-pin connector into the instrument panel opening.

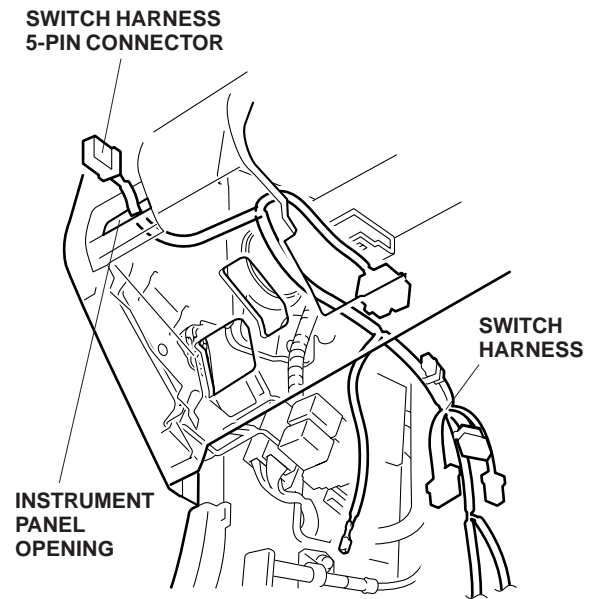

35. Plug the relay into the switch harness relay block.

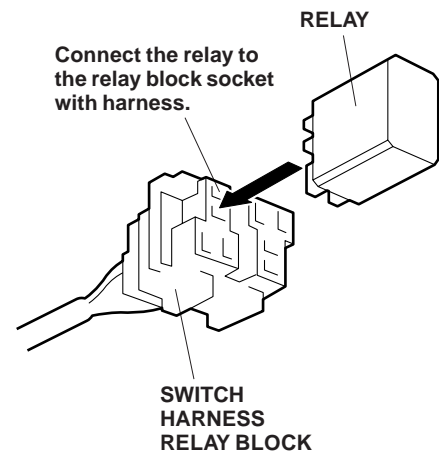

36. Slide the switch harness relay block onto the appropriate bracket, as shown.

With Vehicle Bracket:

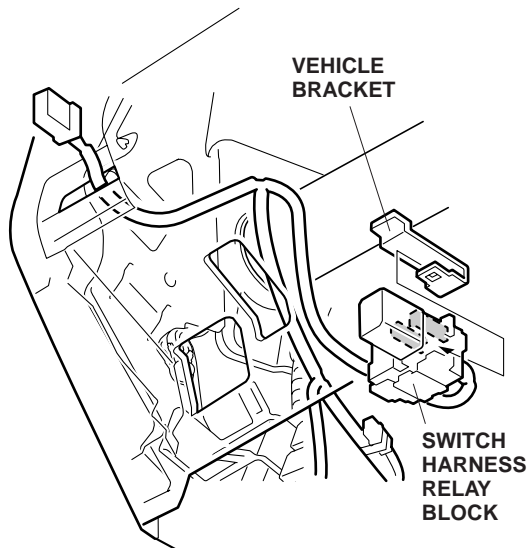

With Vehicle Relay Block:

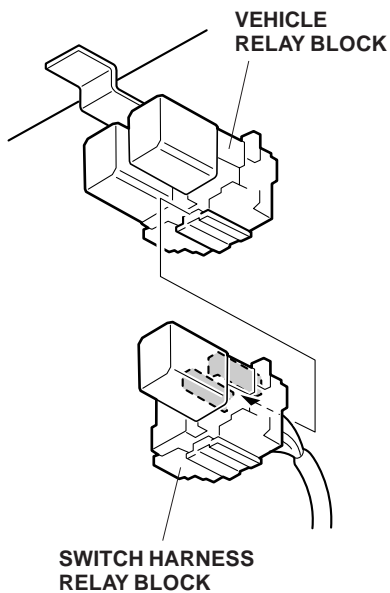

37. Route the switch harness along the body panel through the fuse box area, and secure it to the vehicle harness and body panel with three wire ties.

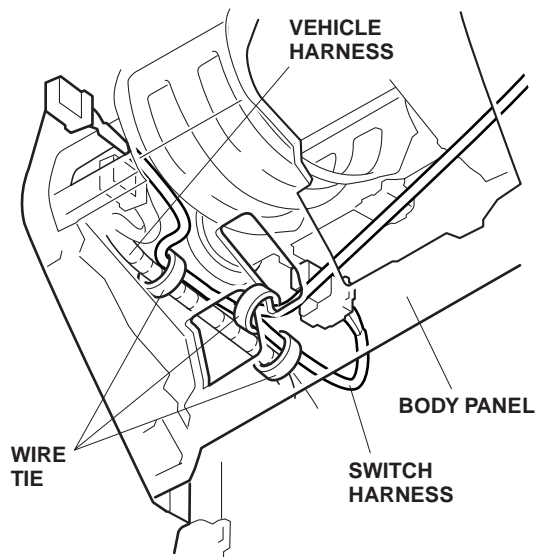

38. Attach the fuse label (20A) to the switch harness fuse case.

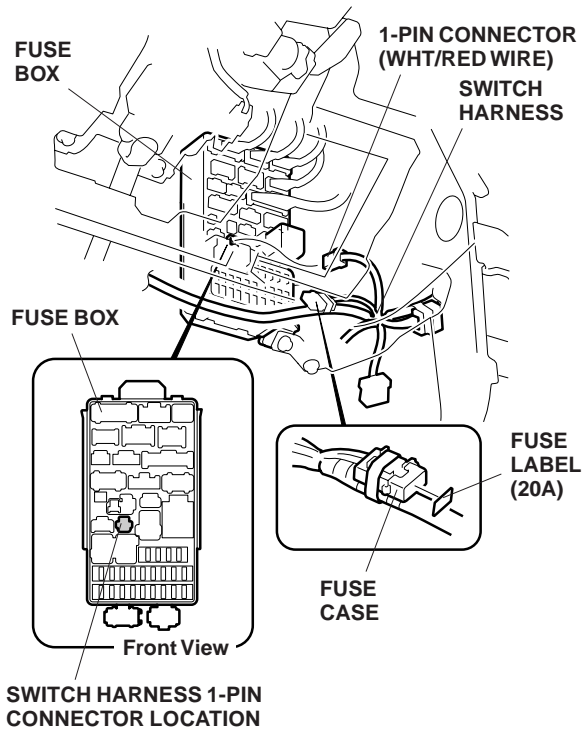

39. Connect the switch harness 1-pin connector (WHT/RED wire) to the fuse box.

NOTE: If the 1-pin connector is already being used by another accessory, plug the switch harness connector into the 1-pin connector taped to the accessory harness.

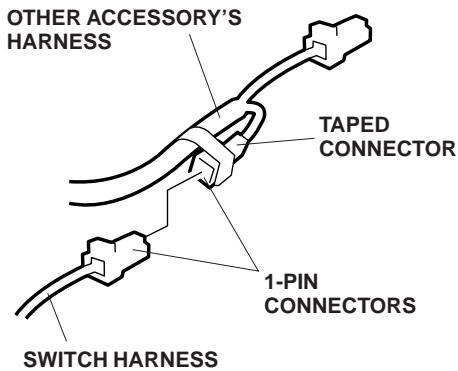

40. On A/T model vehicle, unplug the vehicle 6-pin connector from the fuse box, and connect the switch harness 6-pin connector in between. On M/T model vehicle, plug the switch harness 6-pin connector into the fuse box.

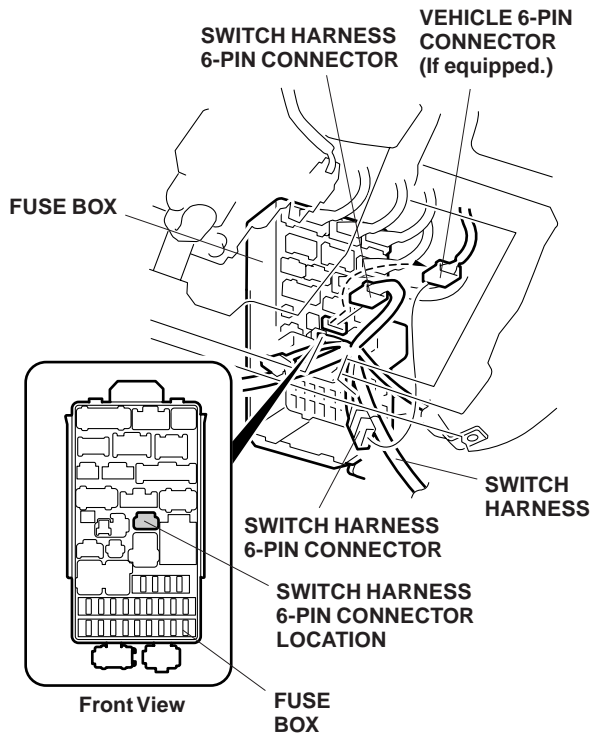

41. On vehicles with a vehicle 1-pin connector on the rear of the fuse box lid: Locate the 1-pin connector blue-taped to the vehicle harness, and connect the switch harness 1-pin connector into the vehicle 1-pin connector.

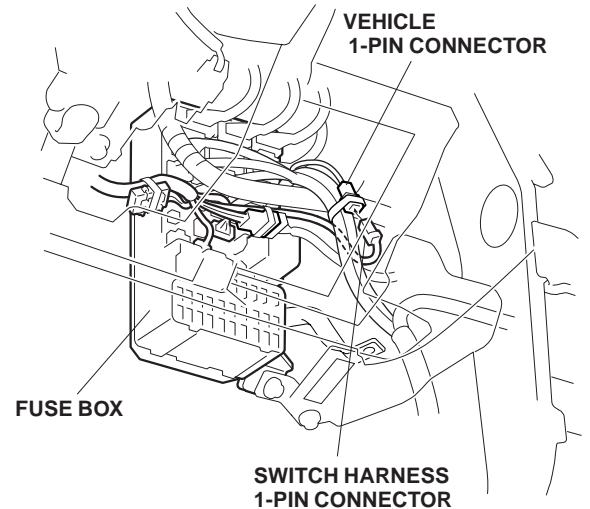

42. On vehicles with a vehicle 1-pin connector on the rear of the vehicle frame: Locate the 1-pin connector blue-taped to the vehicle harness, remove the blue tape, and free the connector. Connect the switch harness 1-pin connector to the vehicle 1-pin connector.

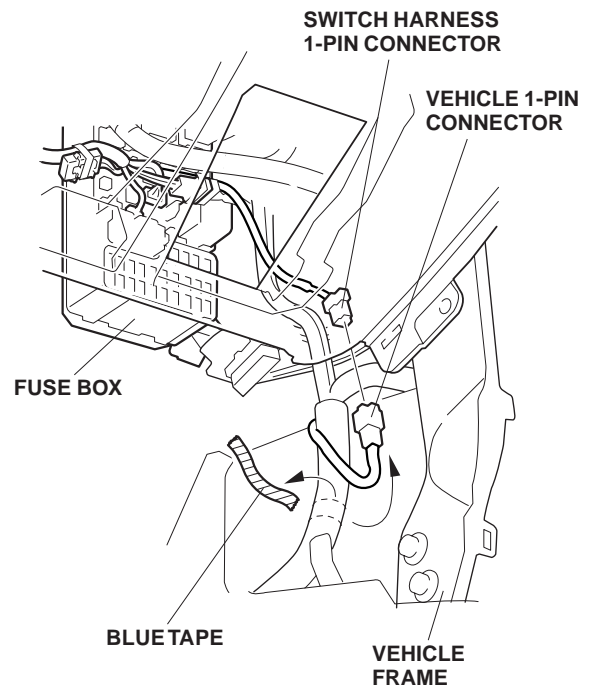

43. Route the switch harness terminal along the vehicle harness above the steering column.

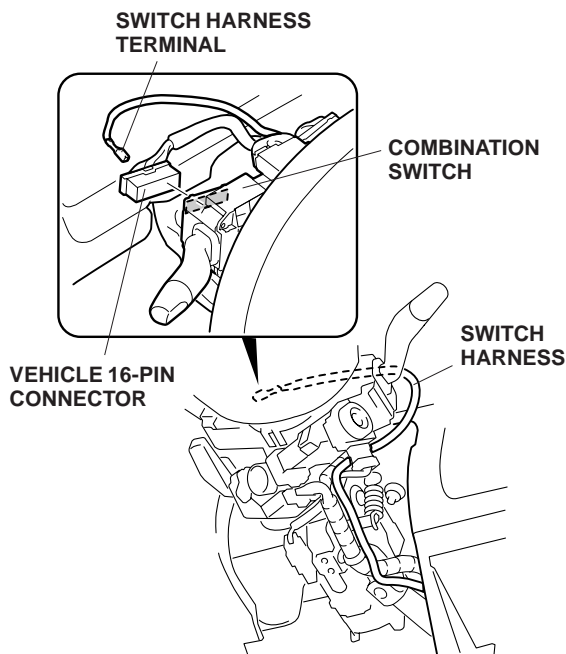

44. Unplug the vehicle 16-pin connector from the combination switch.
45. Release the retainer from the vehicle 16-pin connector. Push the switch harness terminal into the appropriate slot of the 16-pin connector.

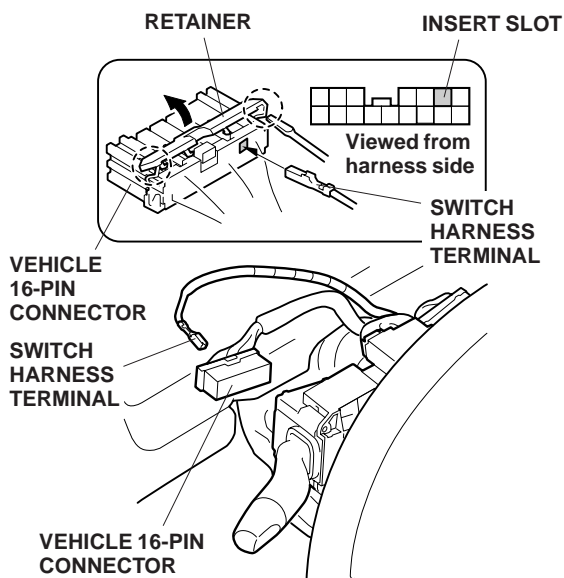

46. Lock the retainer, and plug the vehicle connector back into the combination switch.

47. Route the switch harness 10-pin connector toward the right between the instrument panel and vehicle frame in the area shown.

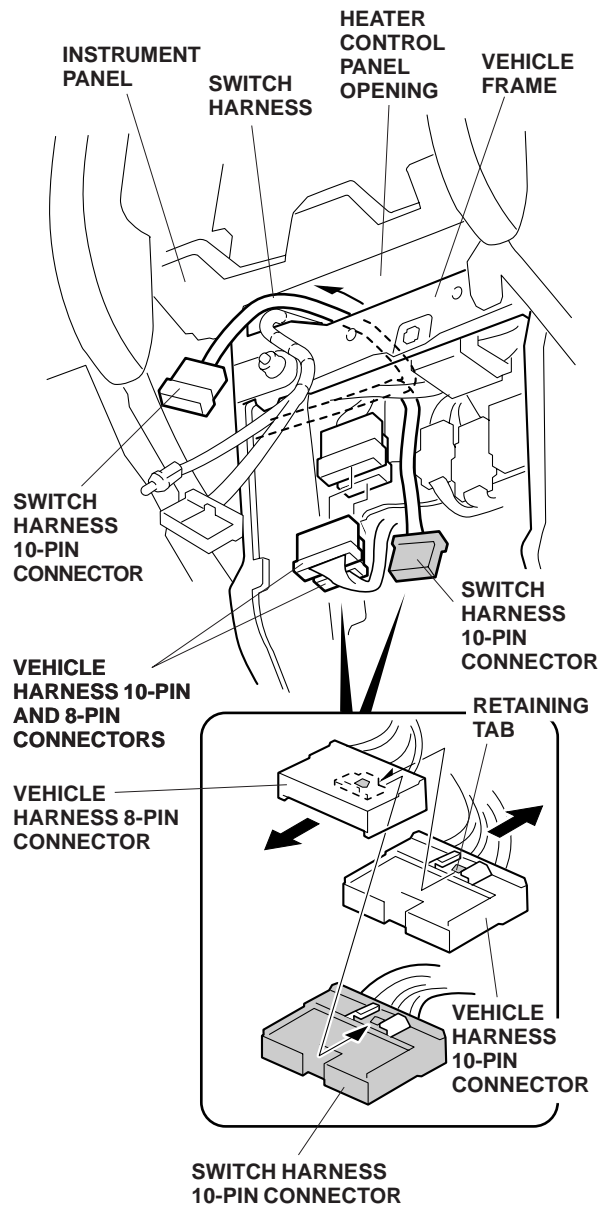

48. Unplug the vehicle harness 10-pin connector and 8-pin connector. Separate the 8-pin connector from the 10-pin connector by sliding them apart.
49. Slide the vehicle 8-pin connector onto the switch harness 10-pin connector.

50. Plug the switch harness 10-pin connector and vehicle harness 8-pin connector into the vehicle 10-pin connector and vehicle 8-pin connector. Plug the other switch harness 10-pin connector into the vehicle harness 10-pin connector. Wrap one EPT sealer around the switch harness 10-pin connector.

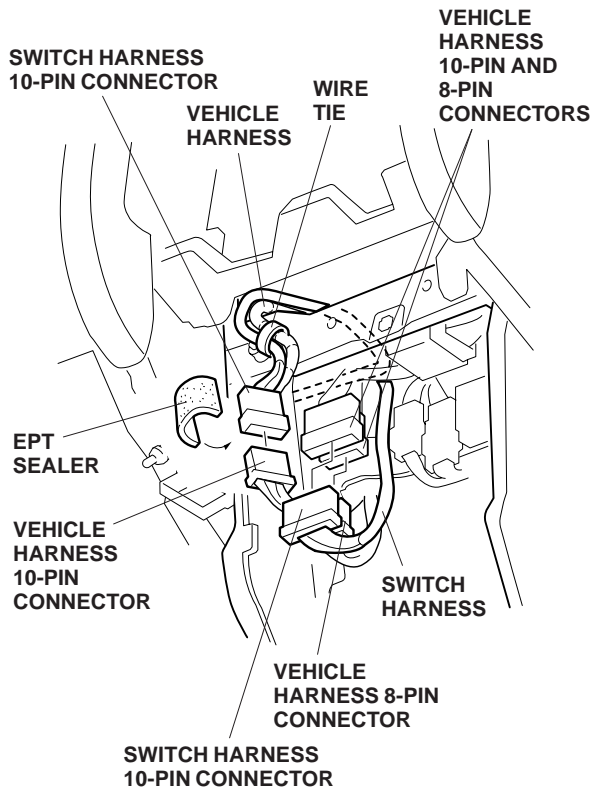

51. Secure the switch harness to the vehicle harness with one wire tie in the area shown.

52. On vehicles with the vehicle 1-pin connector on the rear of the fuse box lid: Continue to secure the switch harness to the vehicle harness with three wire ties. Secure the switch harness fuse case so the cap is clear of the wire ties and can be accessed.

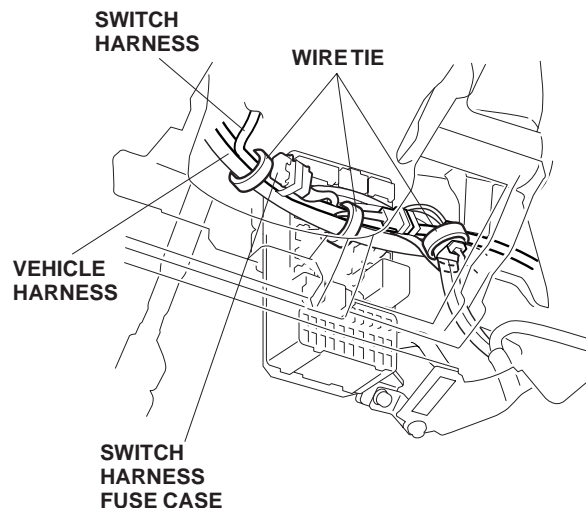

53. On vehicles with the vehicle 1-pin connector on the rear of the vehicle frame: Secure the switch harness to the vehicle harness with four wire ties. Secure the switch harness fuse case on the upper side, so the fuses in the fuse box can be accessed, and so that the vehicle bracket edge does not cut into the switch harness.

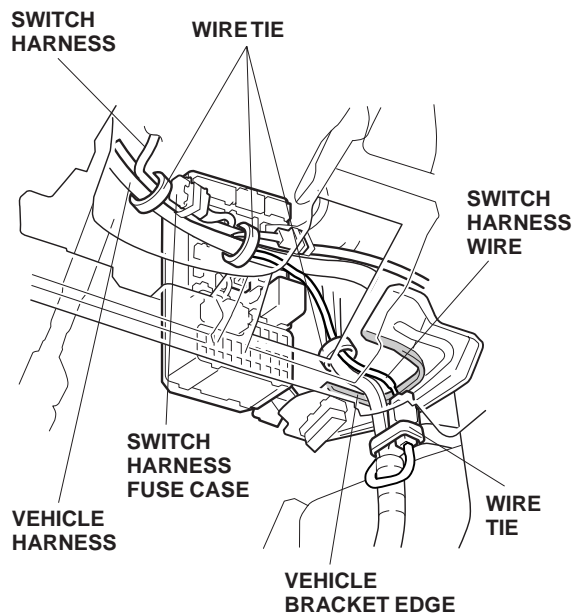

54. Along the steering column, secure the switch harness to the vehicle harness with two wire ties.

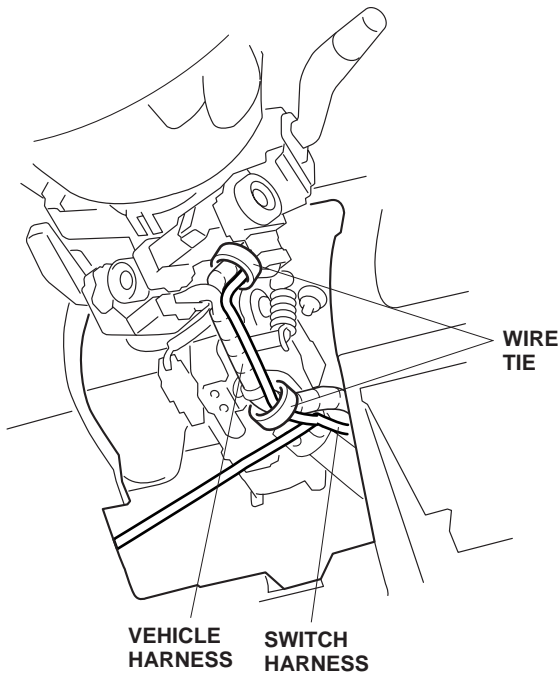

Installing the Switch

55. Remove the two retaining tabs, and remove the right switch lid from the driver's dashboard lower cover.

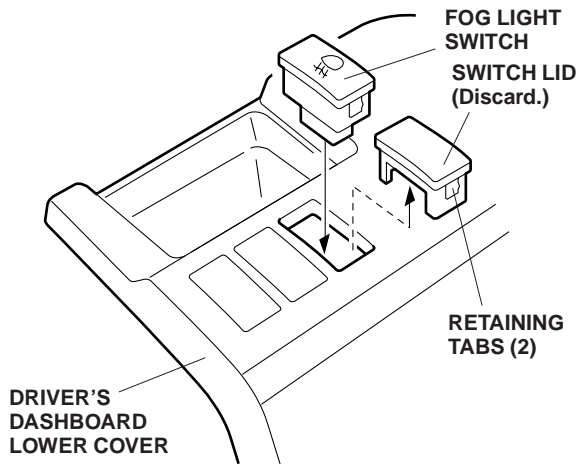

56. Install the fog light switch in the driver's dashboard lower cover.

57. Connect the switch harness 5-pin connector (blue) into the fog light switch, and reinstall the driver's dashboard lower cover.

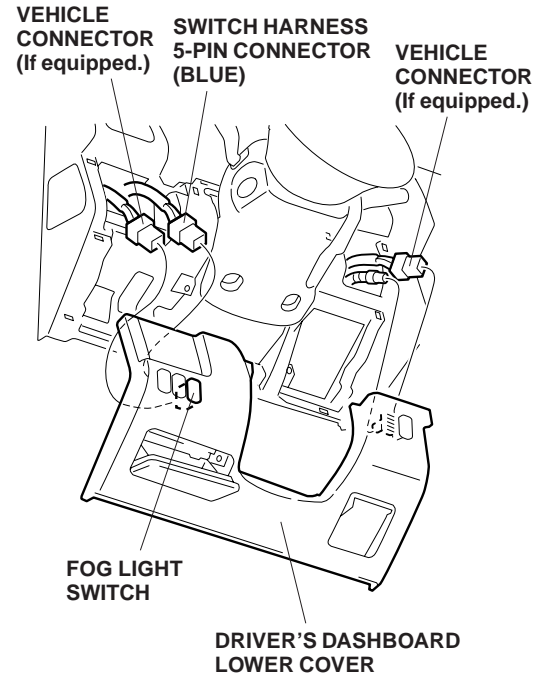

58. Check that all wire harnesses are routed properly and all connectors are plugged in.
59. Reinstall all removed parts. Check that all clips and fasteners are installed securely. Torque the driver's seat bolts to 34 N·m (25 lb-ft).
60. Reconnect the negative cable to the battery.

USE AND CARE

How to Operate Fog Lights

- Turn the light switch to the "on" position (headlights on low beam).
- Press the fog light switch (indicator is on).

The fog light lenses can cloud when the outside temperature is cold; this is normal and should go away in warm weather.

Fog Light Aiming Adjustment

61. Adjust the fog light:

- Adjust the aiming according to local laws and regulations.
- To adjust, turn the aiming adjustment gear in or out until the light is aimed correctly.

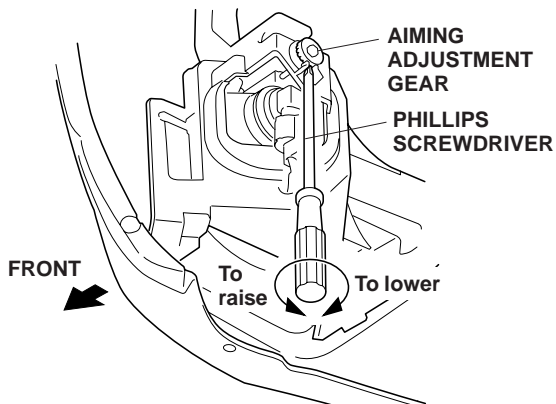

62. Install the inner fenders to the front bumper (four clips and two self-tapping screws).

63. Reset the clock, and reset the radio station presets.

NOTE: Whenever the battery is disconnected, the driver's window AUTO function is disabled.

64. Start the engine. Push down on the driver's window switch until the window is fully open.

65. Pull up on the driver's window switch fully to close the window completely, then hold the switch for 2 seconds.

66. Test the driver's window AUTO function.

BULB REPLACEMENT

1. Remove the two clips and one self-tapping screw, then pull the inner fender out as shown.

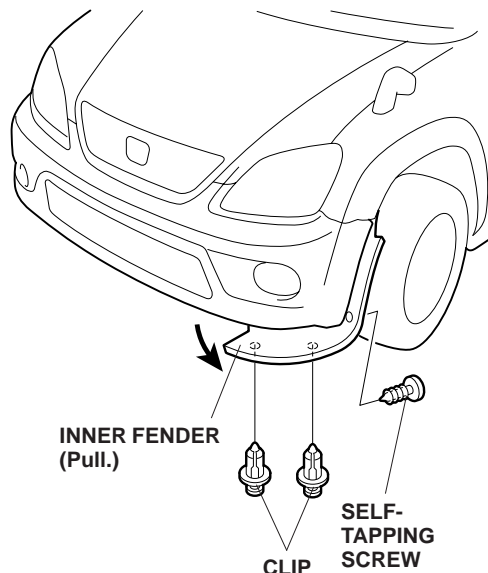

2. Unplug the connector and remove the bulb from the fog light.

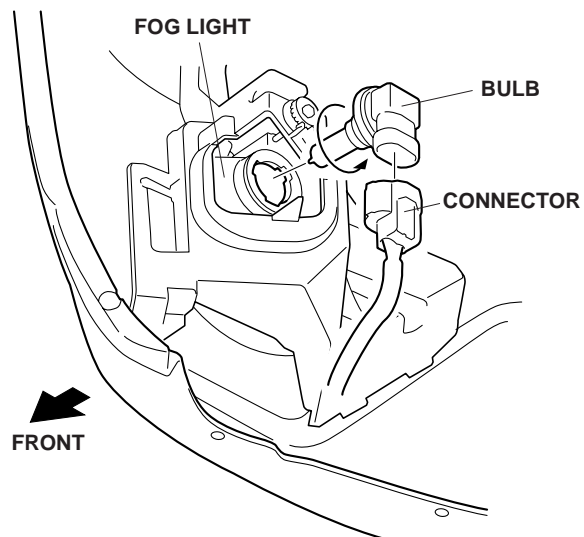

3. Install the new bulb into the fog light and connect the connector to the new bulb.

- Use only a genuine Honda halogen light bulb of specified wattage.

Rating: 12V 55W HB4 Halogen Light Bulb
P/N 33104-SL5-A02-M2

- Do not touch the bulb. Oily or greasy substances on the bulb can shorten its service life due to the heat produced when the bulb is turned on. If the bulb is accidentally touched, wipe it with a clean, soft cloth that has been dampened with a denatured alcohol or a mild detergent solution.
- Align the tab on the fog light with the cutout in the bulb when installing the new bulb. If not aligned, the fog light may annoy oncoming drivers.

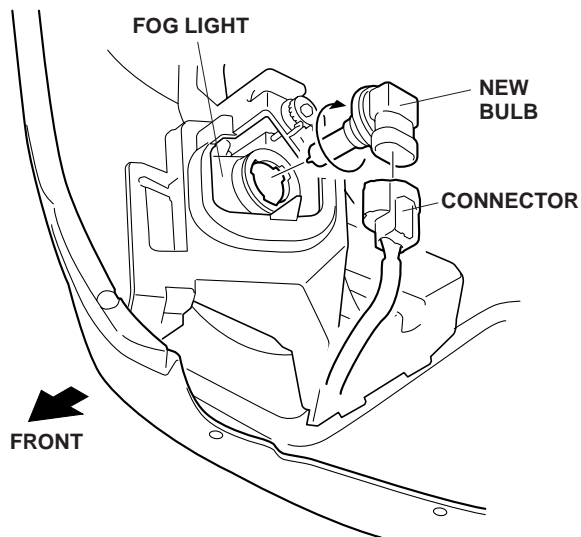

4. Reinstall the removed parts in the reverse order of removal.

- Check that the wire harnesses are not pinched.
- Be sure to tighten the self-tapping screw and bolts securely.

5. Check the operation of the fog light; adjust the aiming if necessary.

CIRCUIT DIAGRAM

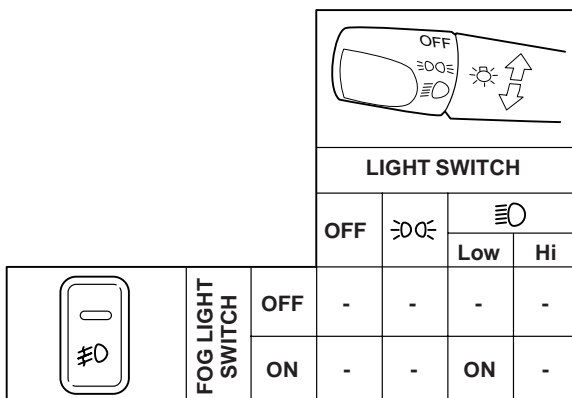
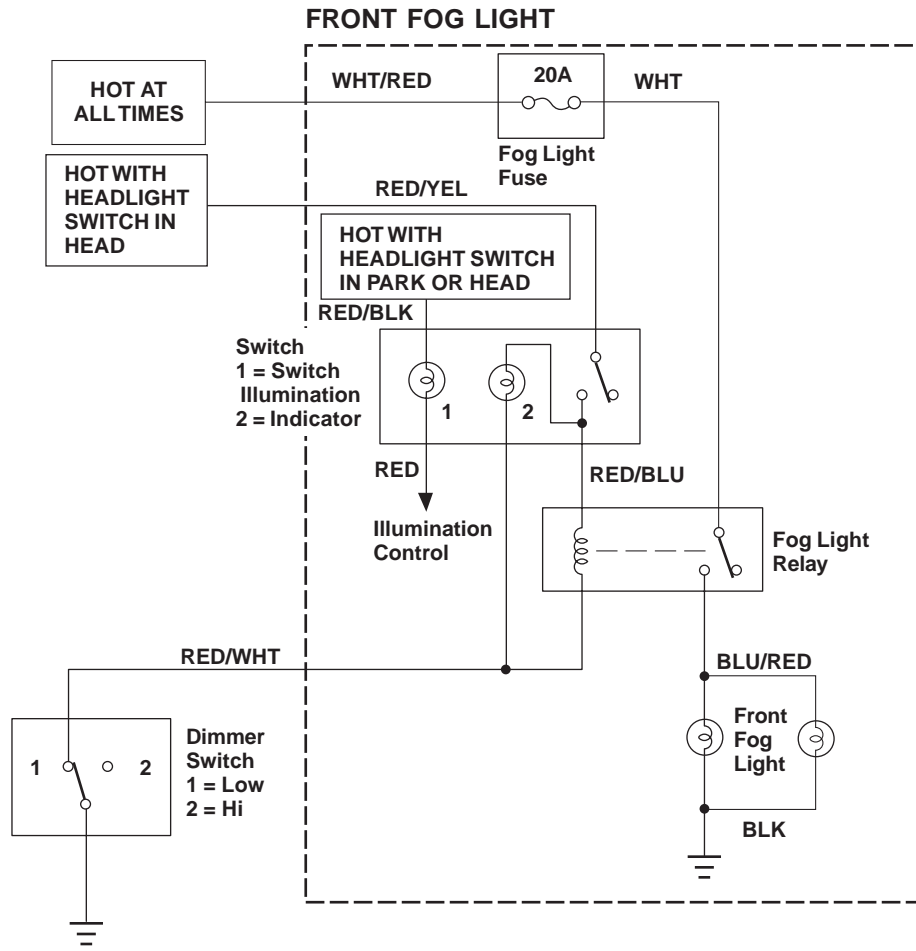

BLK	BLACK	BRN	BROWN
YEL	YELLOW	ORN	ORANGE
BLU	BLUE	PUR	PURPLE
GRN	GREEN	PNK	PINK
RED	RED	GRY	GRAY
WHT	WHITE	LT GRN	LIGHT GREEN
LT BLU	LIGHT BLUE	—	—