



INSTALLATION INSTRUCTIONS

Accessory

**RUNNING BOARD
P/N 08L33-S9A-100B**

Application

CR-V

Publications No.

All 27187

Issue Date

SEP 2004

PARTS LIST

Left running board

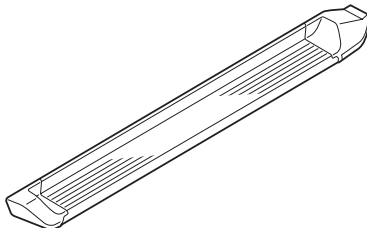

Right running board

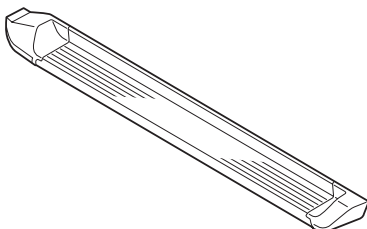

6 Brackets A

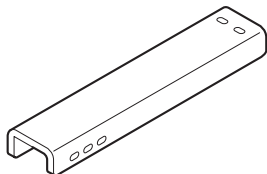

6 Brackets B

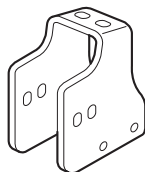

6 Brackets C

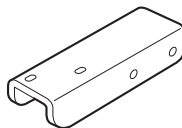

72 Flange bolts



60 Flange nuts



TOOLS REQUIRED

Ratchet

13 mm Combination wrench

13 mm Socket

Torque wrench

INSTALLATION

Customer Information: The information in this Installation Instruction is intended for use only by skilled technicians who have the proper tools, equipment, and training to correctly and safely add equipment to your vehicle. These procedures should not be attempted by "do-it-yourselfers."

NOTE:

- Clean the bottom of the body from the rear of the front wheels up to the front of the rear wheels.
- To prevent damage to the running board during installation, place a blanket under the running board.
- These instructions show the left running board being installed; the same procedure applies to installing the right running board.

1. Position the three brackets B on the underside of the body, and install the two flange bolts for each bracket B. Torque all the flange bolts to 27 N·m (20 lb-ft).

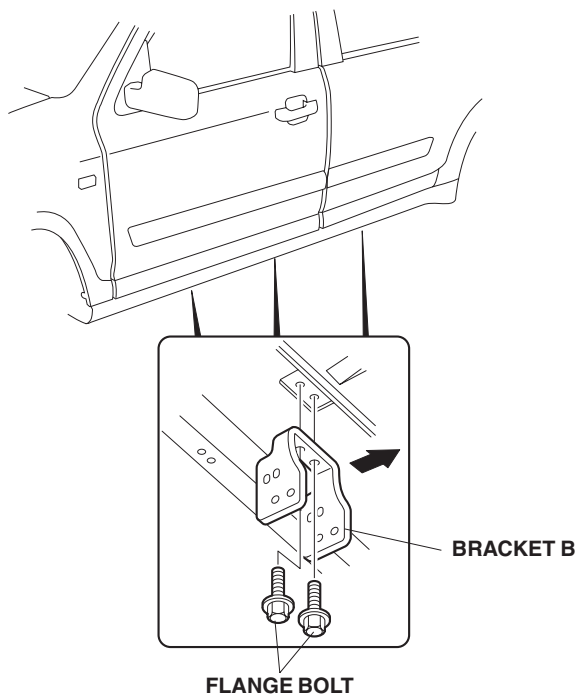

2. Position the three brackets A in the brackets B you just installed, and install the six flange bolts and four flange nuts for each bracket A. Torque all the flange bolts to 27N·m (20 lb-ft).

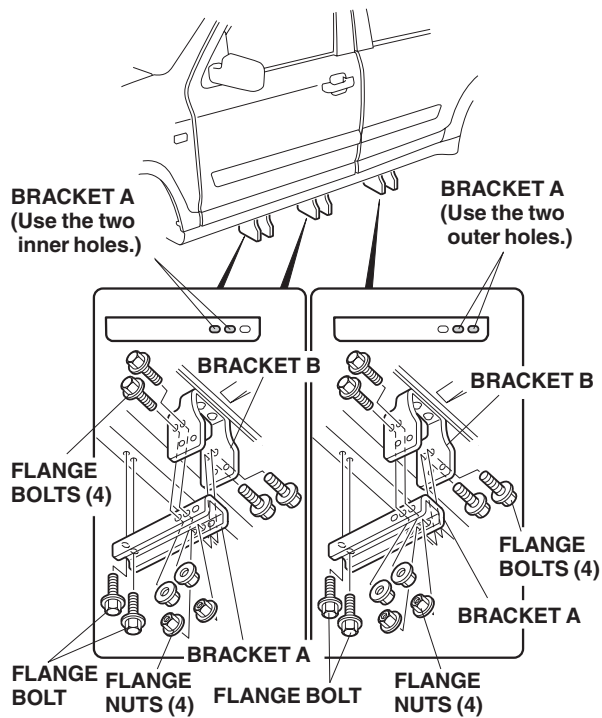

3. Position the three brackets C in the brackets B, and install the two flange bolts and two flange nuts. Do not tighten them yet.

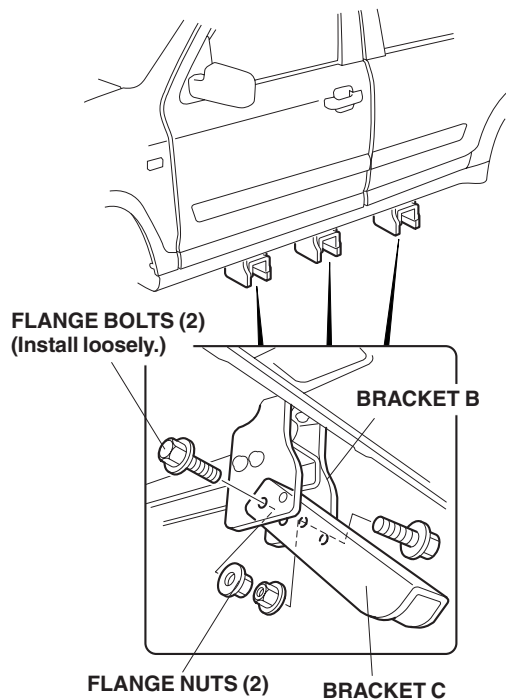

4. Insert the six studs of the running board into the holes in the three brackets C, then install a flange nut on the end of each stud, but do not tighten the flange nuts yet.

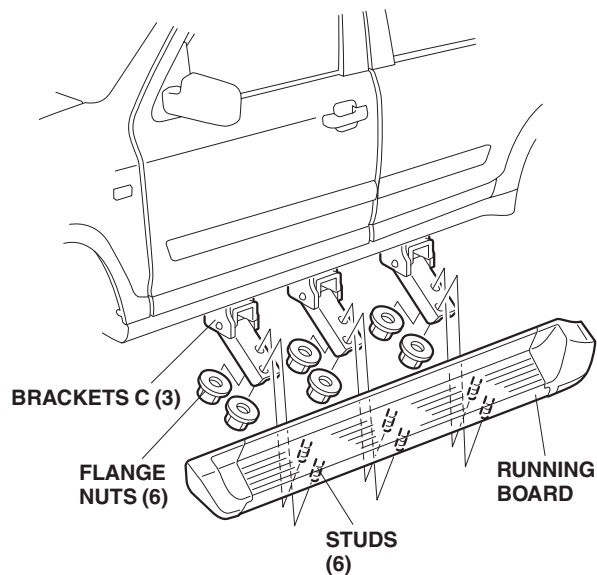

5. Raise the running board to align the holes in the brackets B with the holes in the brackets C. Install and tighten the two flange bolts and two flange nuts.

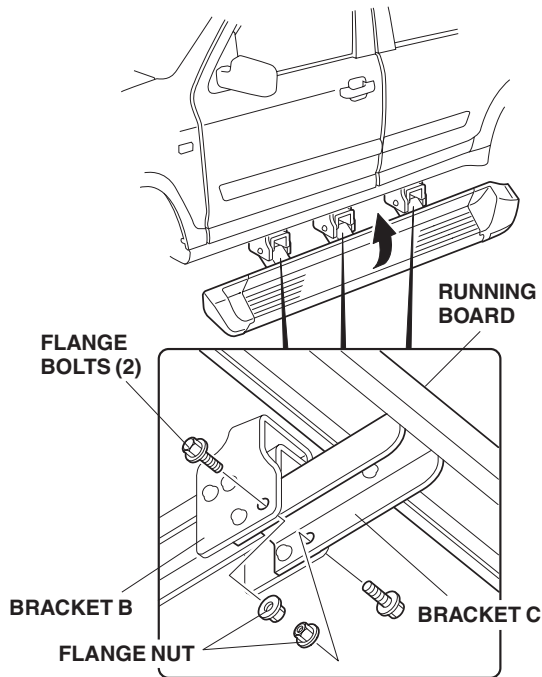

6. Adjust the rear of the running board, so it's flush with the wheel well trim, then tighten the six flange nuts installed in step 4.

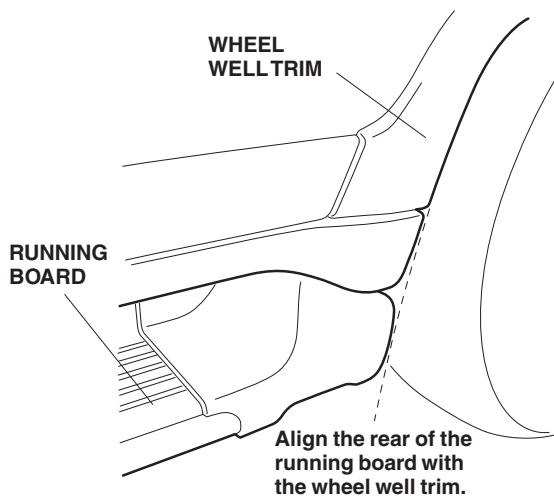

7. Tighten all flange bolts installed in step 3.
8. Torque all the flange nuts and bolts to 27 N·m (20 lb-ft).
9. Repeat steps 1 through 8 to install the running board on the right side.