



INSTALLATION INSTRUCTIONS

Accessory
SECURITY SYSTEM

Application
CR-V

Publications No.
All 27188
Issue Date
SEP 2004

PARTS LIST

Security System
P/N 08E51-EP4-100

Security unit

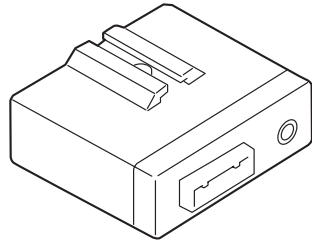

LED



Push nut



2-pin connector (for LED)

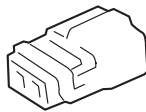

Microphone

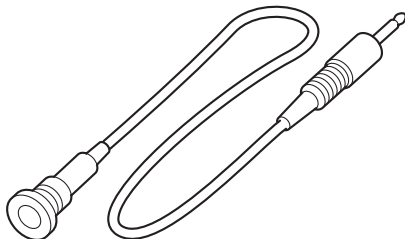

Window decal

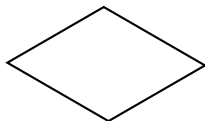

Owner's manual

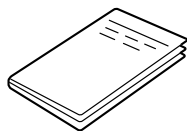

Security System Attachment P/N 08E55-S9A-100

Security harness

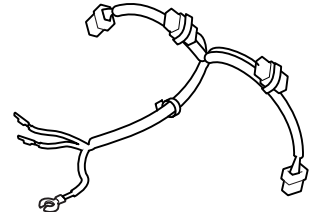

Unit bracket

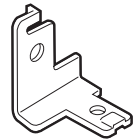

Fuse label

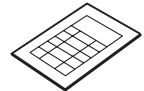

2 Cushion tapes

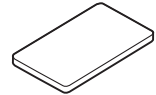

Ground bolt



4 Wire ties

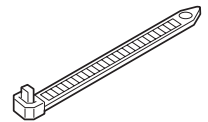

TOOL AND SUPPLIES REQUIRED

#2 Phillips screwdriver

Small flat-tip screwdriver

Felt-tip pen

10 mm Combination wrench

10 mm Socket

Ratchet

Center punch

Drill

3 mm, 5.5 mm, 8 mm Drill bits

Eye protection (face shield, safety goggles, etc.)

Isopropyl alcohol

Tape measure

Illustration of the Security System Installed on the Vehicle

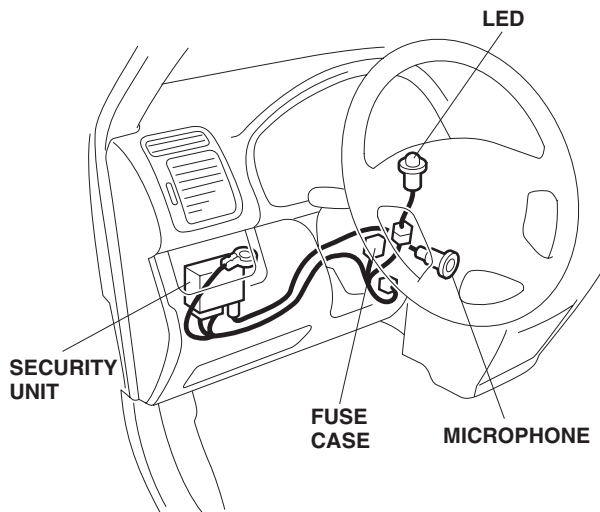

INSTALLATION

Customer Information: The information in this installation instruction is intended for use only by skilled technicians who have the proper tools, equipment, and training to correctly and safely add equipment to your vehicle. These procedures should not be attempted by “do-it-yourselfers.”

1. Make sure you have the anti-theft code for the radio, then write down the radio station presets.
2. Disconnect the negative cable from the battery.
3. Remove the driver's dashboard under cover by turning the knob clockwise, and releasing one clip.

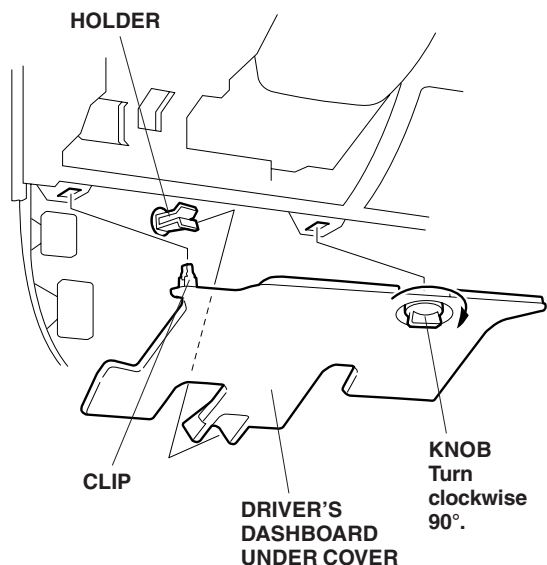

4. Remove the driver's dashboard lower cover:
 - Remove the fuse box lid, and open the pocket.
 - Remove the two self-tapping screws.
 - Gently pull out on the driver's dashboard lower cover to release the eight clips. If equipped, unplug the vehicle connector and remove the lower cover.

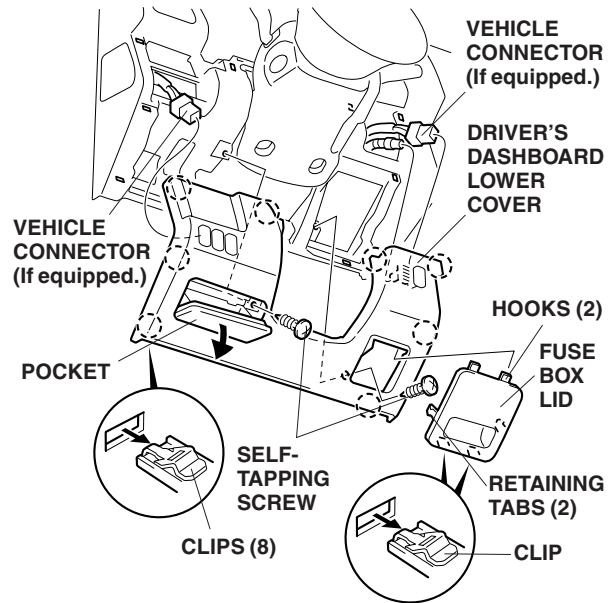

5. Lower the steering wheel tilt lever. Remove the upper and lower steering column covers. (two self-tapping screws, one screw, and six tabs). Gently push on the six retaining tabs, and separate the two steering column covers.

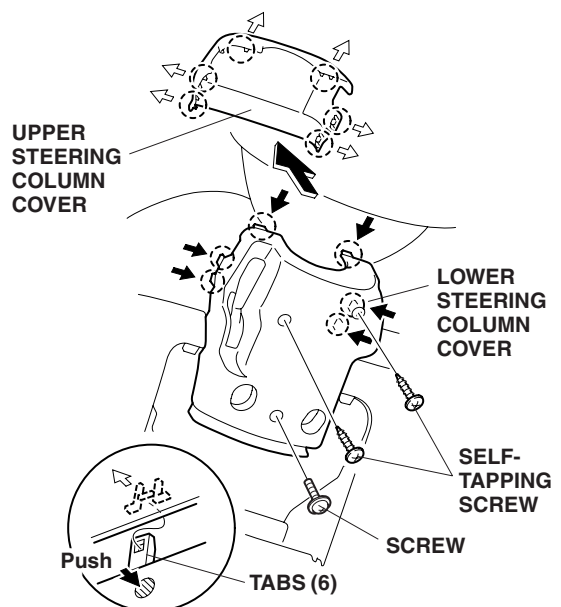

6. Measure and mark the upper steering column cover.

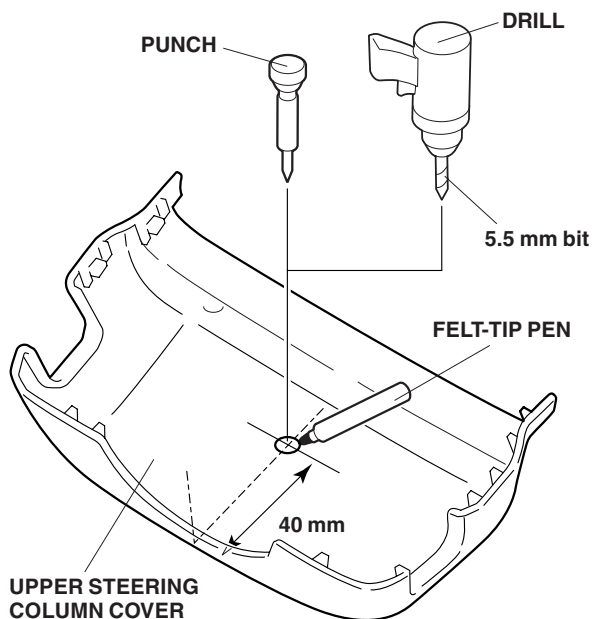

7. While wearing eye protection, lightly center-punch the mark, and drill a 5.5 mm hole through the upper steering column cover. Remove all burrs.
8. Route the terminal ends of the LED through the hole you just drilled, and secure the LED with the push nut. Using isopropyl alcohol, clean the area where the half of the cushion tape will attach. Secure the harness of the LED to the back of the upper column cover with half of a cushion tape.

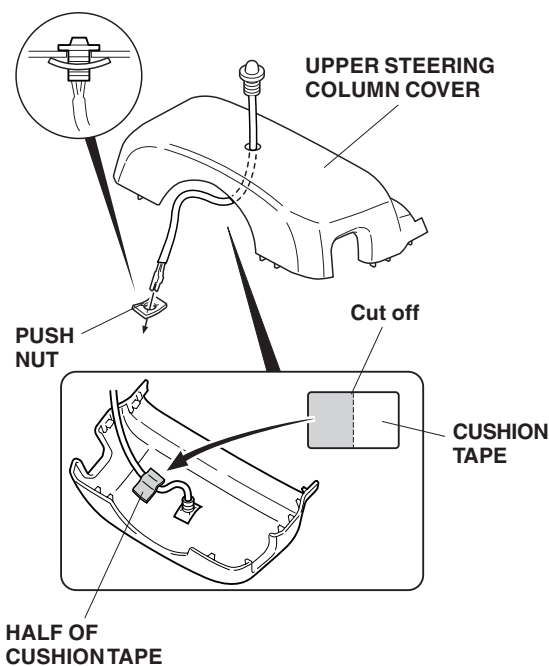

9. Locate the 2-pin connector from the kit. Firmly push the LED terminals into the 2-pin connector, and lower the lock.

NOTE: If the wires are not correctly installed in the connector, the LED will not work.

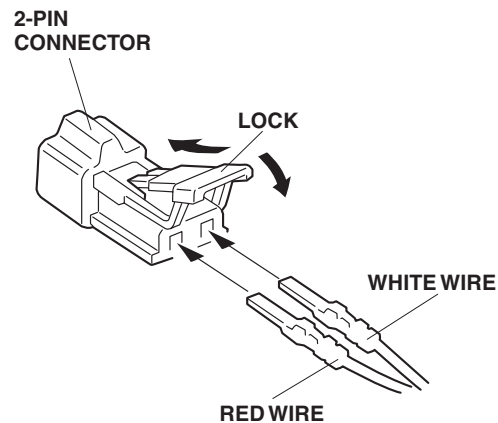

10. Measure and mark the driver's dashboard lower cover.

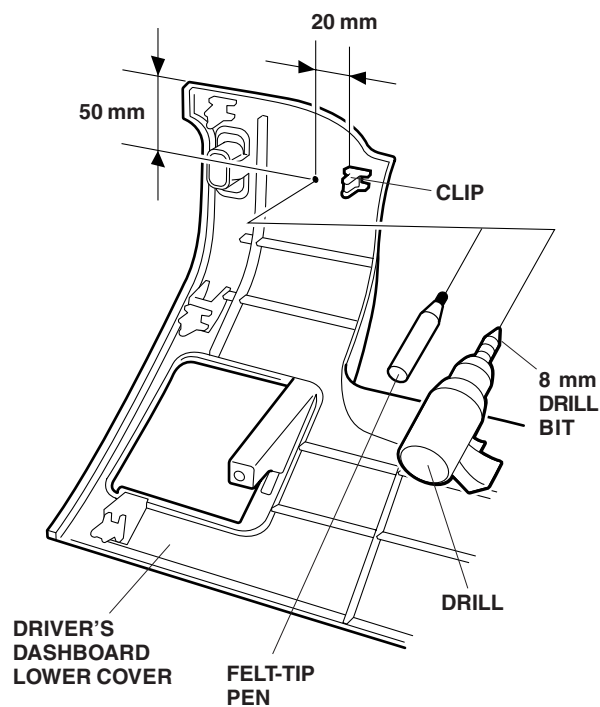

11. While wearing eye protection, lightly center-punch the mark, and drill an 8 mm hole through the center-punched mark, Remove all burrs.

- First drill a pilot hole with a 3 mm drill bit, then finish with an 8 mm drill bit.

- Route the microphone jack through the hole you just drilled, and secure the microphone in the hole.

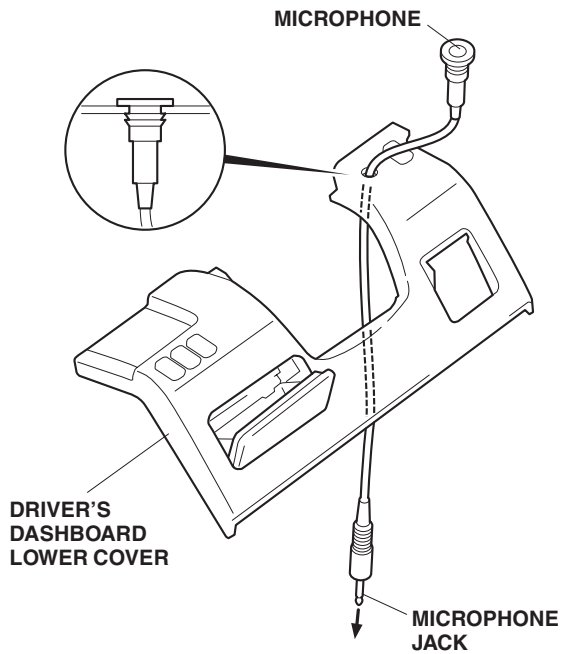

- Attach the unit bracket to the security unit by pushing the bracket into place. Do not push the connector area.

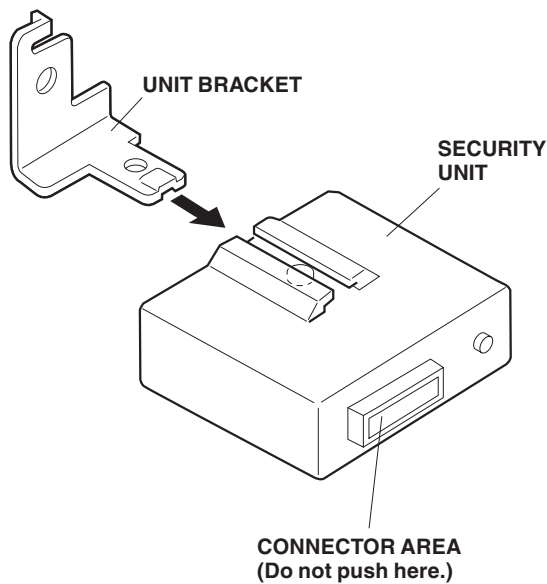

- Remove and discard the mounting bolt, and remove cruise control.

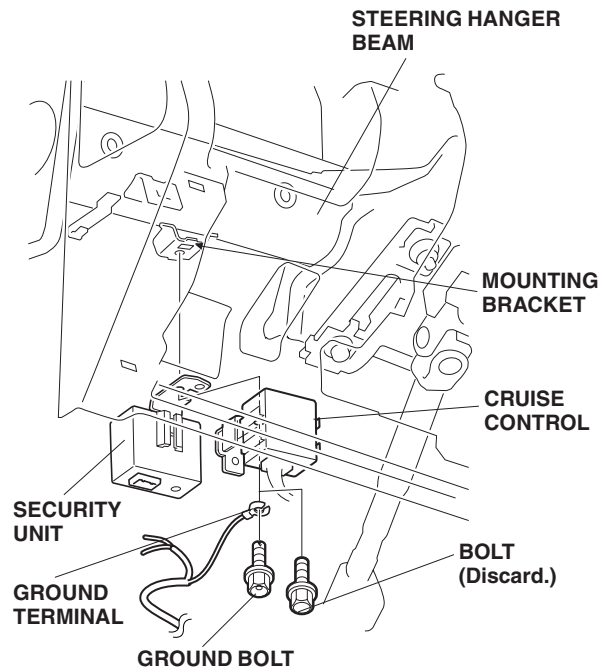

- Align the security unit, the cruise control unit, the ground terminal, and the mounting bracket on the steering hanger beam. Install the new ground bolt from the kit.

- On the left side of the steering shaft bracket, locate the 22-pin connector taped to the vehicle harness, and remove the tape to free the connector. Release the lock on the 22-pin connector, and push the white and white/red wire terminals from the security harness into the appropriate cavities in the 22-pin connector. Reattach the lock on the 22-pin connector, and then plug it into the security unit.

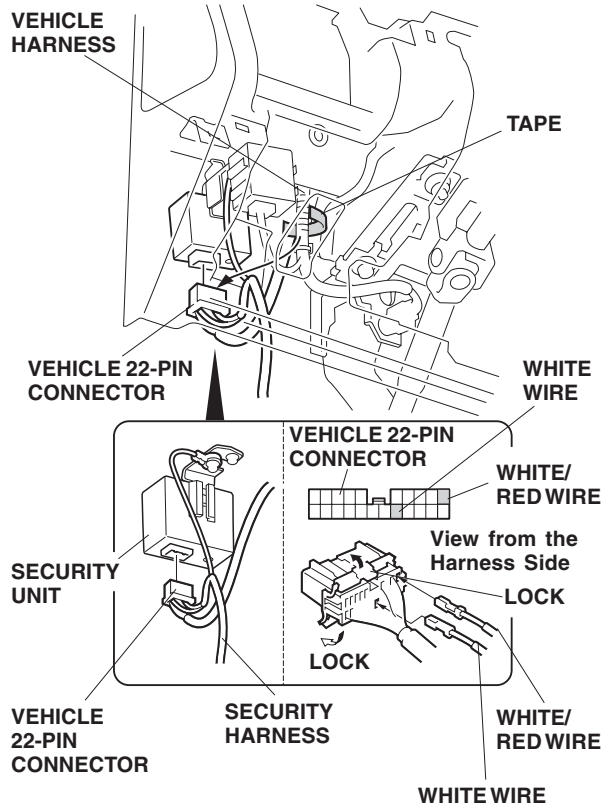

- Route the security harness above the steering column and secure it to the hole in the right front corner of the steering bracket with the clip on the security harness.

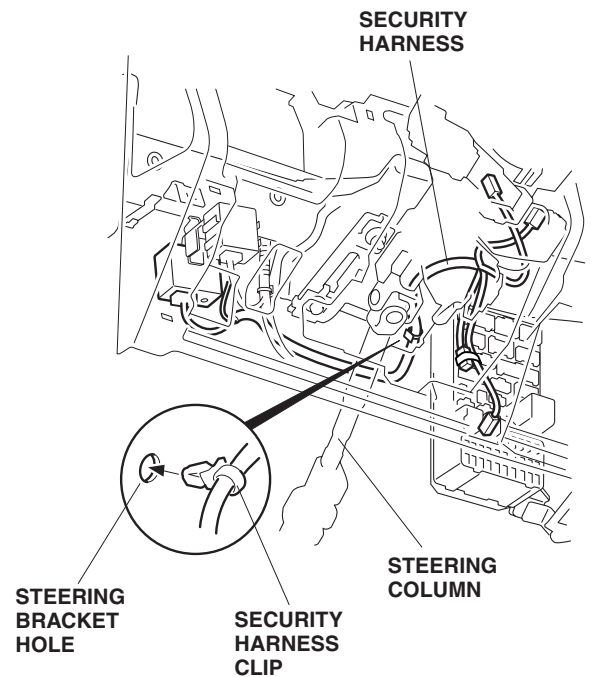

- Plug the security harness 1-pin connector into the fuse box accessory terminal (+B).

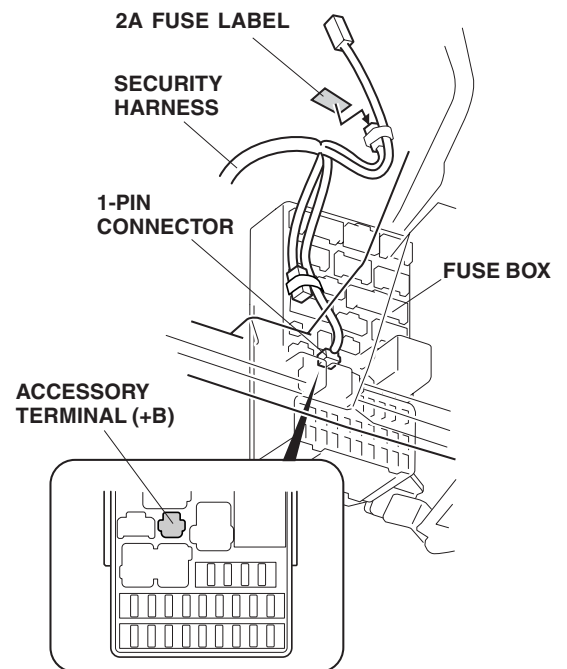

- Attach the 2A fuse label to the security harness fuse case.

NOTE: If another accessory is already plugged into the 1-pin connector: Connect the 1-pin connector from the other accessory harness into the 1-pin connector taped to the security harness, then connect the 1-pin connector from the security harness into the fuse box.

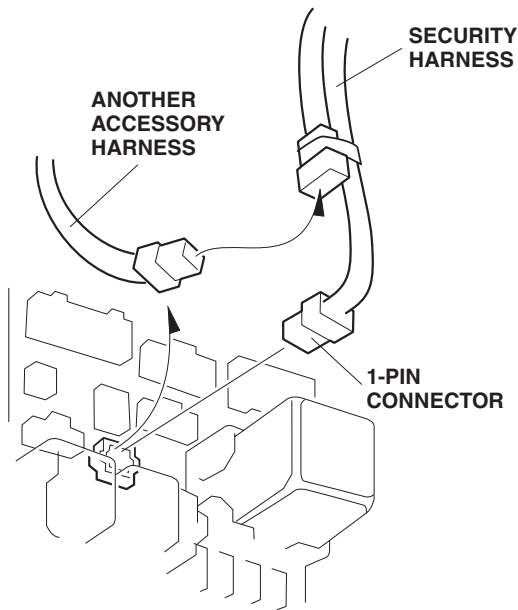

20. Reinstall the upper column cover; then, route the LED harness along the vehicle harness.

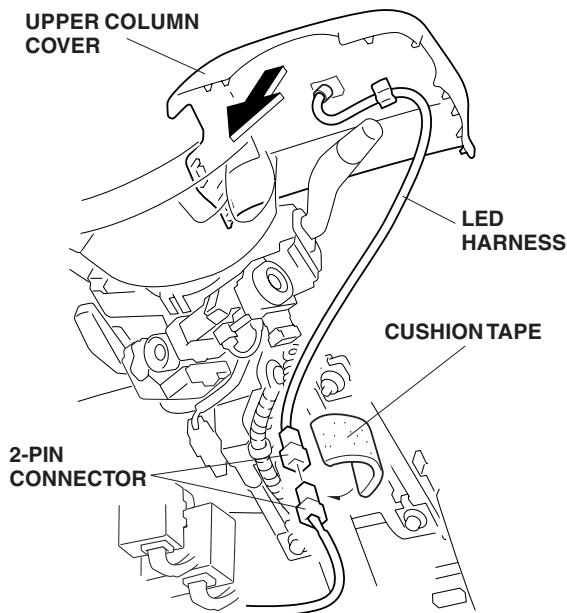

21. Connect the LED harness 2-pin connector to the security harness 2-pin connector, and wrap one cushion tape around the 2-pin connectors.

22. Reinstall the lower column cover.

23. Route the microphone cord along the security harness, and plug the microphone jack into the security unit. Secure the microphone cord to the vehicle harness with the one wire tie.

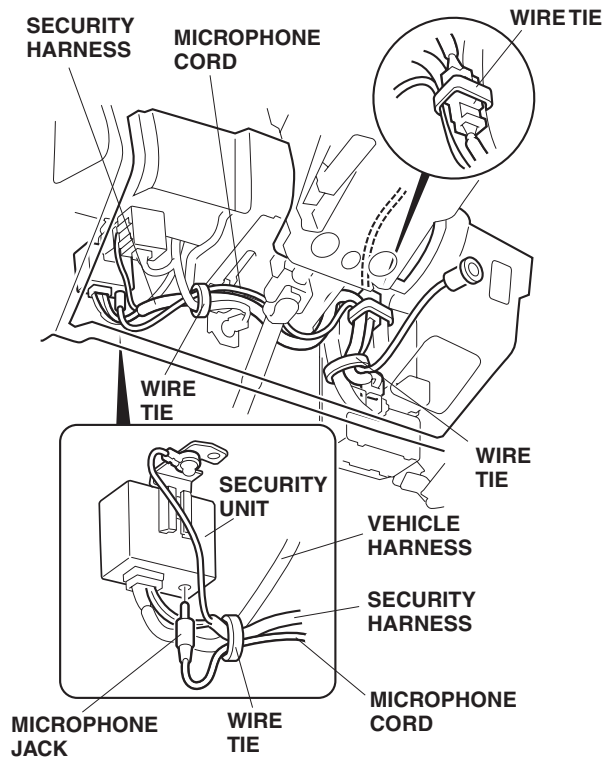

24. Secure the security harness and microphone cord to the vehicle harness with three wire ties in the area shown.

25. Check that all wire harnesses are routed properly and all connectors are plugged in.

26. Reinstall all removed parts.

27. Reconnect the negative cable to the battery.

28. Enter the customer's radio anti-theft code, and reset the radio station presets.

29. Reset the clock.

30. Check operation of the security system according to the Security System owner's manual supplied.

NOTE: Whenever the battery is disconnected, the driver's window AUTO function is disabled.

31. Start the engine. Push down on the driver's window switch until the window is fully open.

32. Pull up on the driver's window switch fully to close the window completely, then hold the switch for 2 seconds or more.

33. Test the driver's window AUTO function.