



INSTALLATION INSTRUCTIONS

Accessory	Application	Publications No.
TRAILER HITCH	ELEMENT	All 28695
		Issue Date JAN 2005

PARTS LIST

Trailer Hitch Kit
P/N 08L92-SCV-100

Trailer hitch

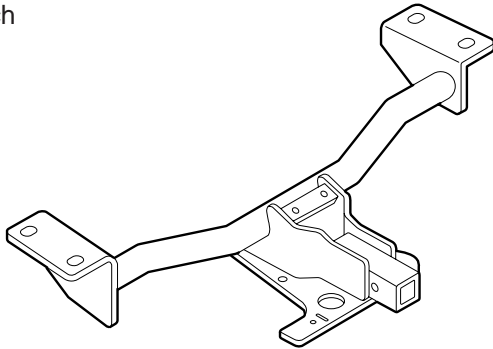

Left stay

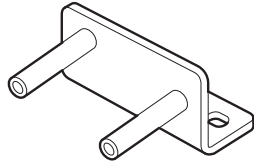

Right stay

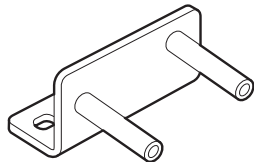

4 Side plates



Ball mount

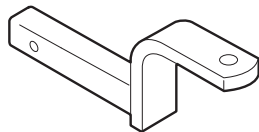

4 Bolts, 12 x 135 mm



4 Bolts, 12 x 35 mm



U-bolt

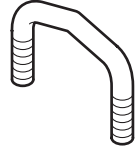

2 Nuts, 8 mm



2 Washers, 8 mm



2 Spring washers, 8 mm



8 Nuts, 12 mm



12 Washers, 12 mm



8 Spring washers, 12 mm



Retaining pin

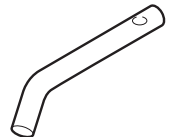

Retaining pin clip



Receiver cover

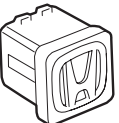

**Harness Kit (sold separately)
P/N 08L91-SCV-102**

Trailer harness

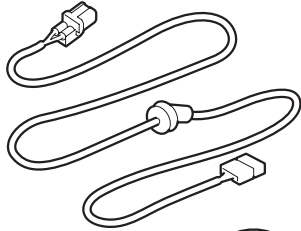

Trailer unit harness

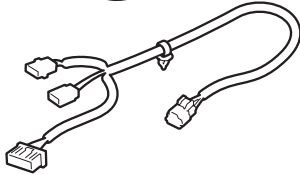

Trailer unit

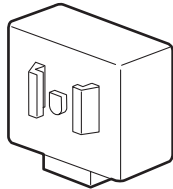

Connector bracket

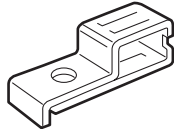

Unit bracket

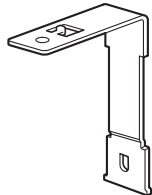

Flange nut



2 Flange bolts



8 Wire ties

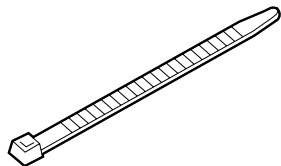

2 Wire tie with clips

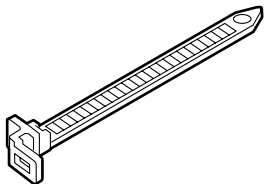

Bracket

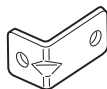

Fuse label A

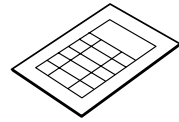

Fuse label B



3 EPT sealers

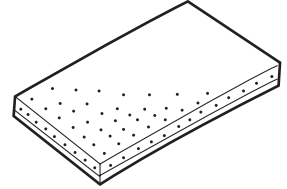

Fuse, 7.5A

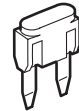

Owner's Manual

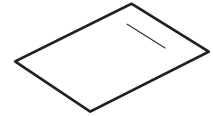

3 Cushion tapes

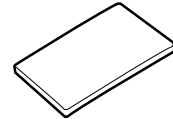

TOOLS AND SUPPLIES REQUIRED

Phillips screwdriver

Flat-tip screwdriver

10 mm, 13 mm, 14 mm and 19 mm Combination wrenches

Torque wrench

Tape measure

Diagonal cutters

Piece of steel wire

Isopropyl alcohol

Shop towel

Cardboard or blanket

12 mm T-wrench

Clip remover

Utility knife

Scissors

INSTALLATION

Customer information: The information in this installation instruction is intended for use only by skilled technicians who have the proper tools, equipment, and training to correctly and safely add equipment to your vehicle. These procedures should not be attempted by "do-it-yourselfers."

1. Make sure you have the anti-theft code for the radio, then write down the radio station presets.
2. Disconnect the negative cable from the battery.

Routing the Trailer Harness

3. Remove the rear bumper (two 4 x 20 mm self-tapping screws, two 5 x 16 mm self-tapping screws, two bolts, two clips).

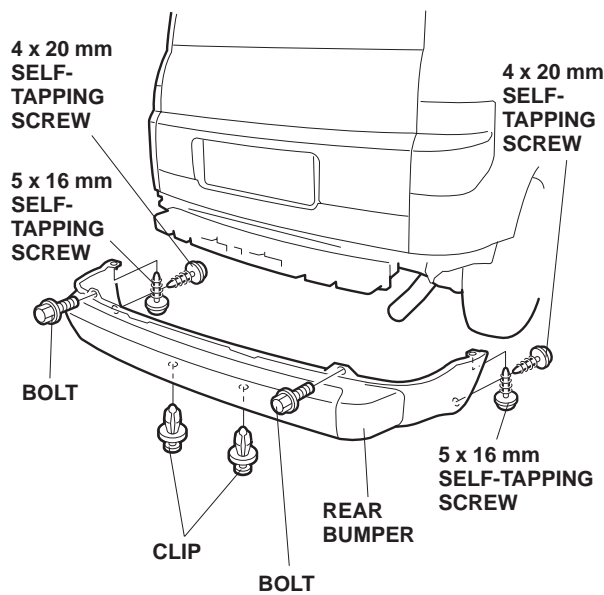

4. Open the upper and lower tailgates and take out the cargo area floor (two hooks).

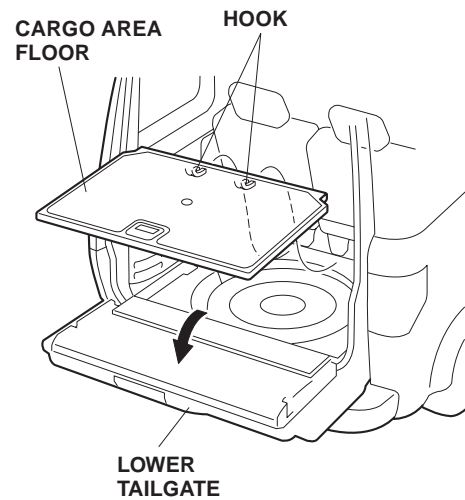

5. Get the trailer harness and two EPT sealers. Attach the EPT sealers to the trailer harness at the location shown.

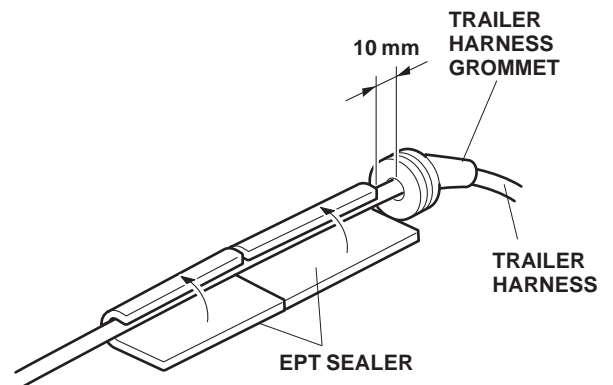

6. Inside the spare tire well, turn over the lower half of the plastic hole cover, attached to the square hole in the inner panel, to the slit in the center.

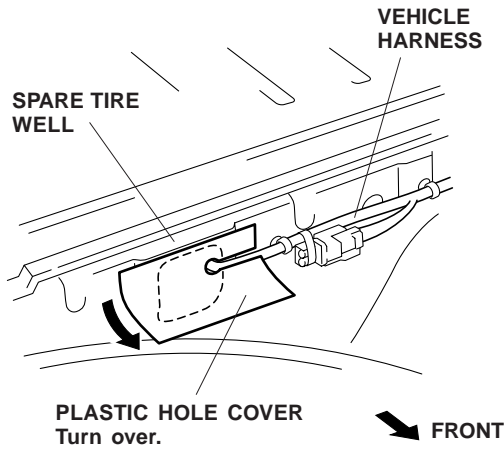

7. Remove and discard the rear left grommet from the body. Attach a piece of steel wire to the trailer harness 4-pin connector and pull the 4-pin connector through the vehicle grommet hole and into the hole in the spare tire well. Seat the trailer harness grommet in the vehicle grommet hole with the end facing down.

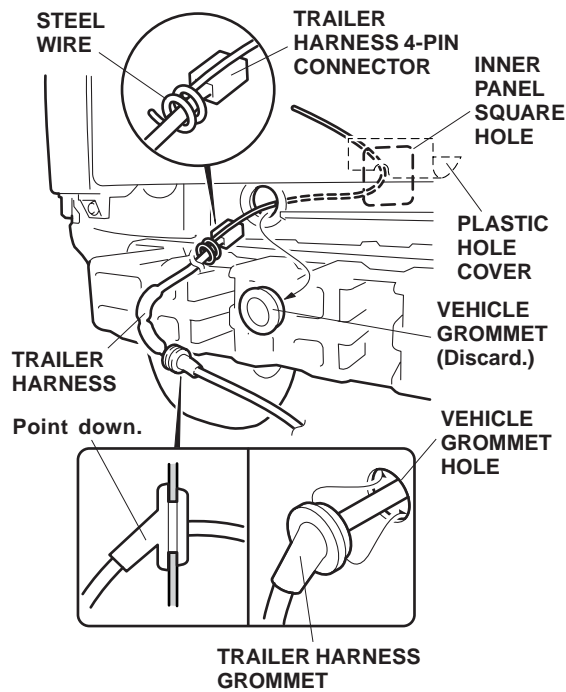

8. Remove the steel wire from the trailer harness 4-pin connector.

9. Install a wire tie with clip to the trailer harness 4-pin connector. Remove the blue tape to free the vehicle harness 4-pin connector in the spare tire well. Remove the dummy connector from the vehicle harness 4-pin connector and connect the harness connector to the 4-pin connector of the trailer harness. Secure the connectors to the vehicle harness with the wire tie with clip and wrap an EPT sealer (cut in half) around the connector.

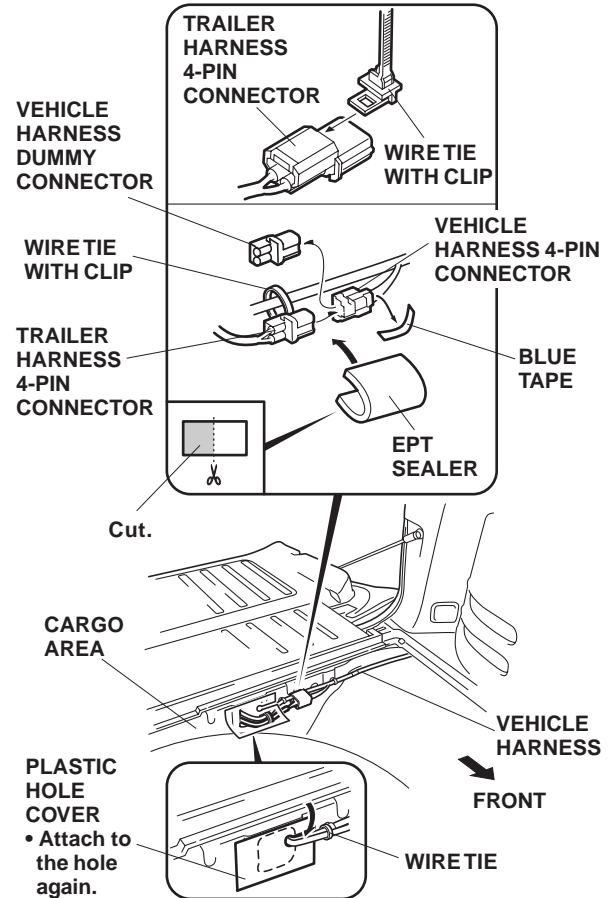

10. Secure the trailer harness to the vehicle harness with one wire tie as shown. Route the trailer harness through the square hole in the inner panel and reattach the plastic hole cover.

11. Route the trailer harness down through the clearance between the rear bumper beam and body panel, and reinstall the rear bumper.

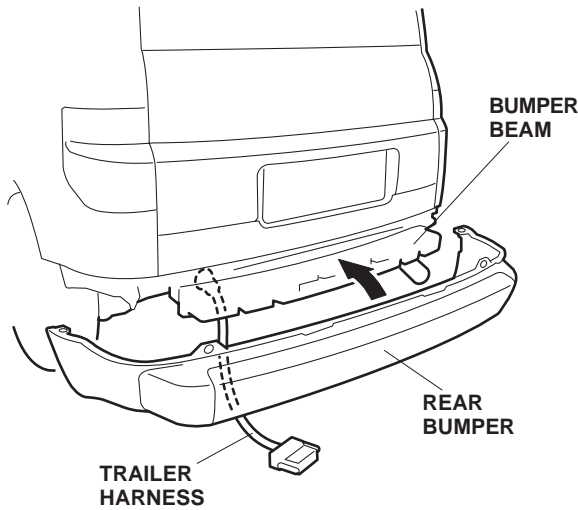

Routing the Trailer Unit Harness

12. Slide the driver's seat all the way forward and raise the seat to the highest position. Behind the driver's seat, remove the eight clips that secure the rear cover to the vehicle panel and remove the cover. Take care not to damage the clips. If the seals came off the clips, reattach the seals to the clips.

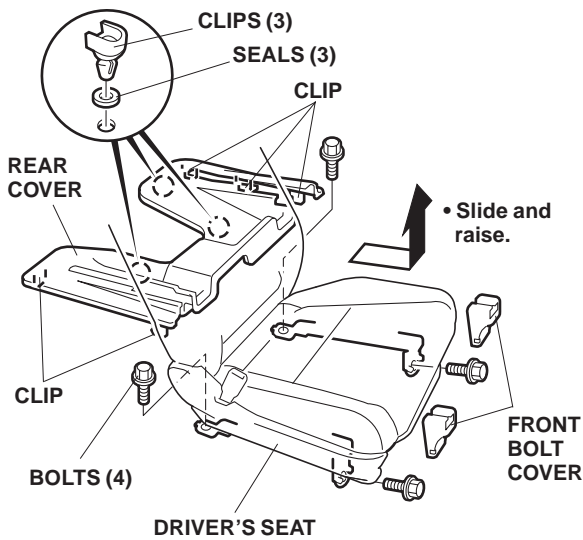

13. Remove the two front bolt covers, then remove the four bolts that fasten the driver's seat side rails so that the driver's seat can be lifted.

14. Remove the driver's door side sill trim (nine clips and two retaining tabs). Take care not to damage the clips and retaining tabs. If the seals came off the clips, reattach the seals to the clips.

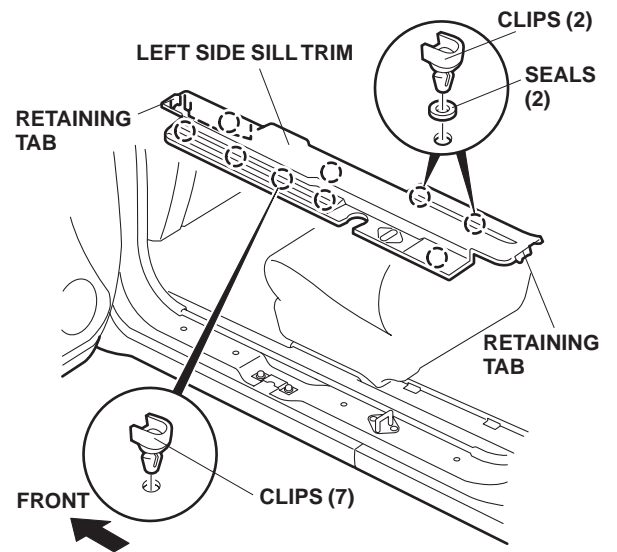

15. To remove the driver's dashboard lower cover, turn the knobs clockwise, then pull the lower cover out toward you to release the six retaining tabs.

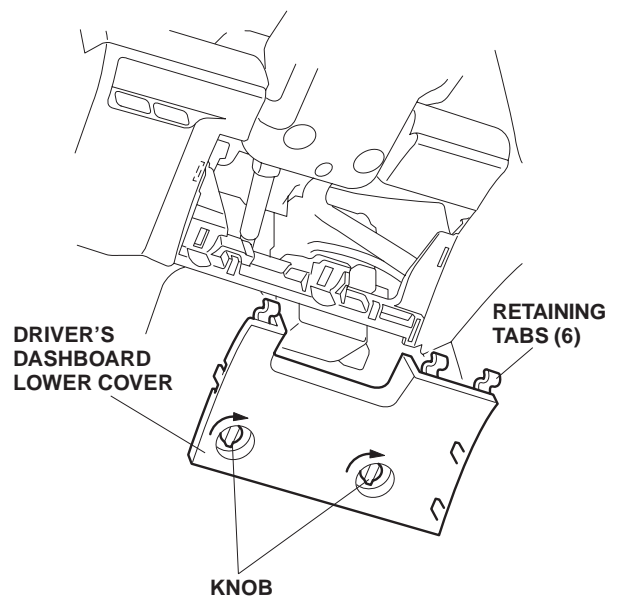

16. Remove the weatherstrip around the driver's kick panel, and remove the driver's kick panel (pull the driver's kick panel out toward you to release the two clips and two hooks). Take care not to damage the clips and hooks.

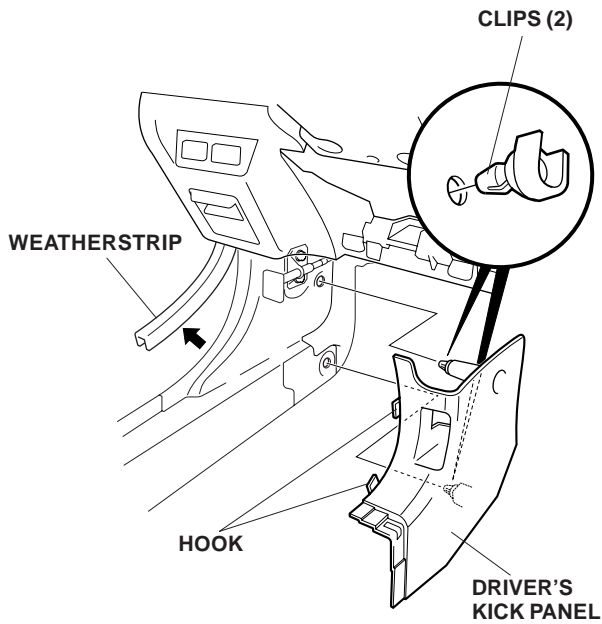

17. Slide the unit bracket onto the trailer unit. Do not push at the connector area.

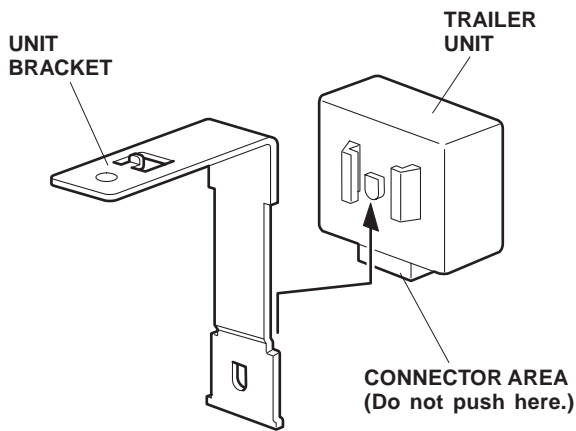

18. Install the trailer unit.

Without Keyless Entry System:

Attach the unit bracket to the steering hanger beam with the flange bolt (from the kit).

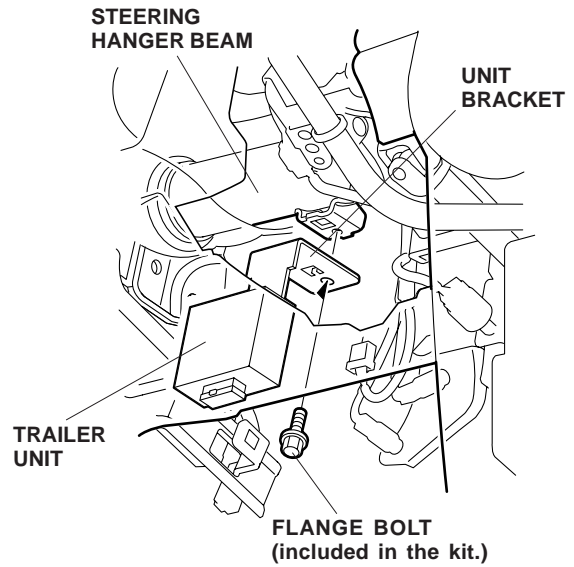

With Standard Keyless Entry System:

Unplug the vehicle 5-pin connector from the keyless receiver unit, and remove the vehicle bracket from the steering hanger beam (one bolt).

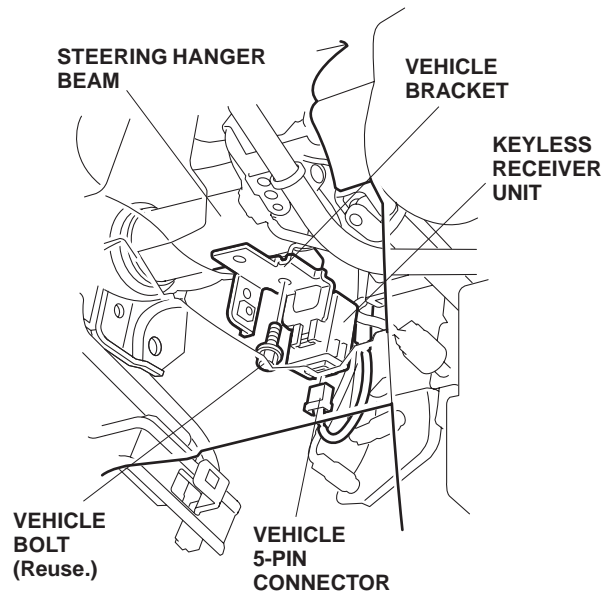

Combine the vehicle bracket and the unit bracket and attach them with the vehicle bolt you removed. Reconnect the 5-pin connector to the keyless receiver unit.

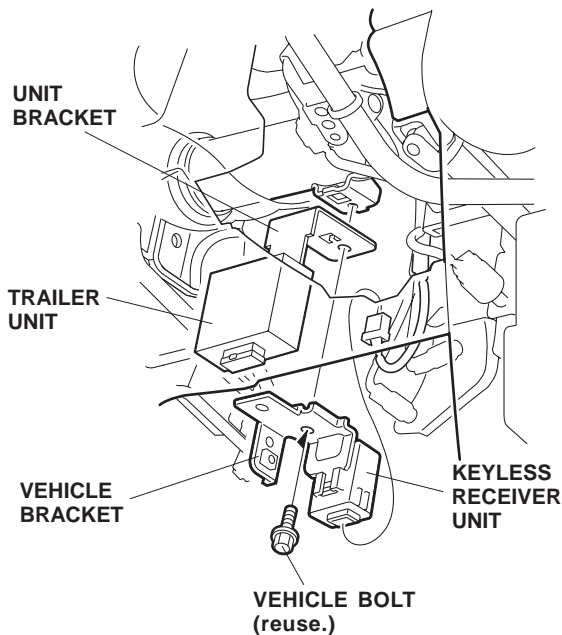

With Optional Security System:

Combine the keyless entry unit bracket and the unit bracket and attach them with the flange bolt (included in the kit).

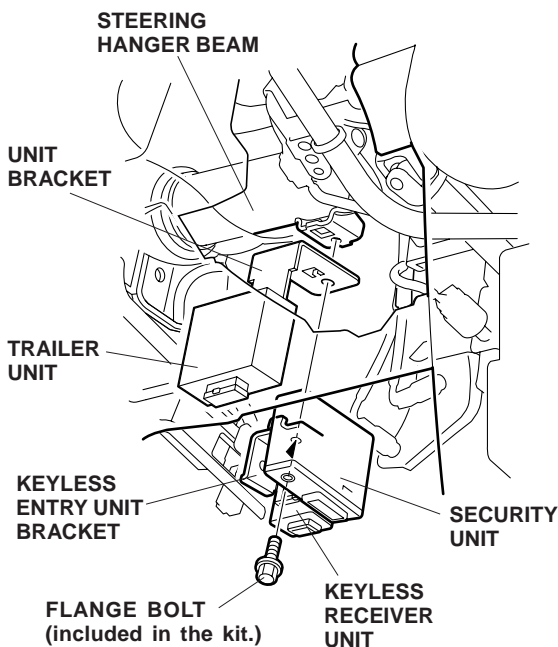

- Attach the fuse label A (OPTION FUSE 5A) to the fuse case of the trailer unit harness. Remove the blue tape from the vehicle harness, free the vehicle 6-pin connector, and connect the 6-pin connector of the trailer unit harness.

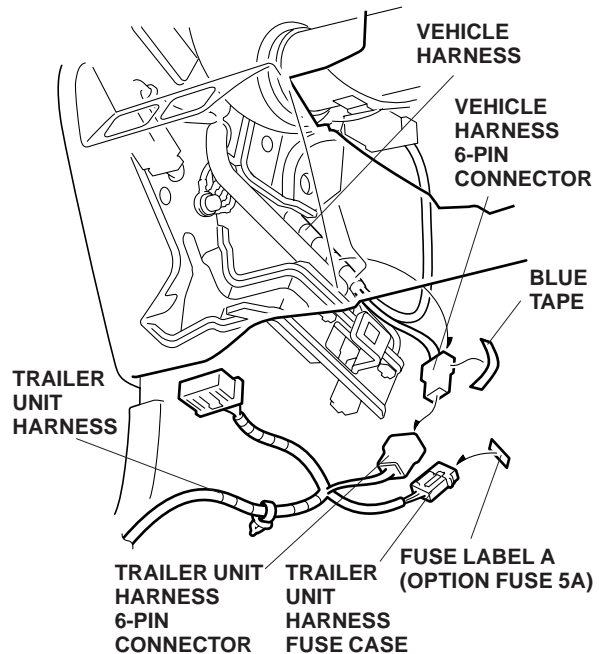

- Install the fuse case of the trailer unit harness by sliding it onto the coupler holder of the vehicle harness.

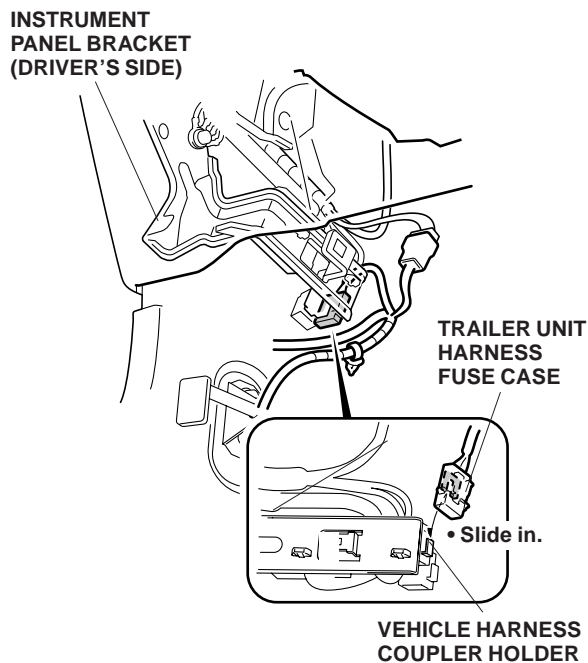

21. Remove the vehicle bolt from the bottom hood opener bracket and install the bracket from the kit, reusing the vehicle bolt.

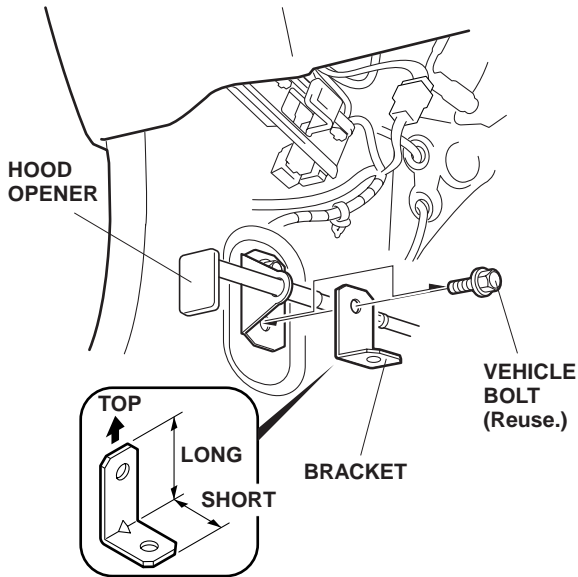

22. Connect the trailer unit harness 12-pin connector to the trailer unit and secure the trailer unit harness to the instrument panel bracket with one wire tie. When installing the wire tie, do not damage the trailer unit harness with the edge of the instrument panel bracket.

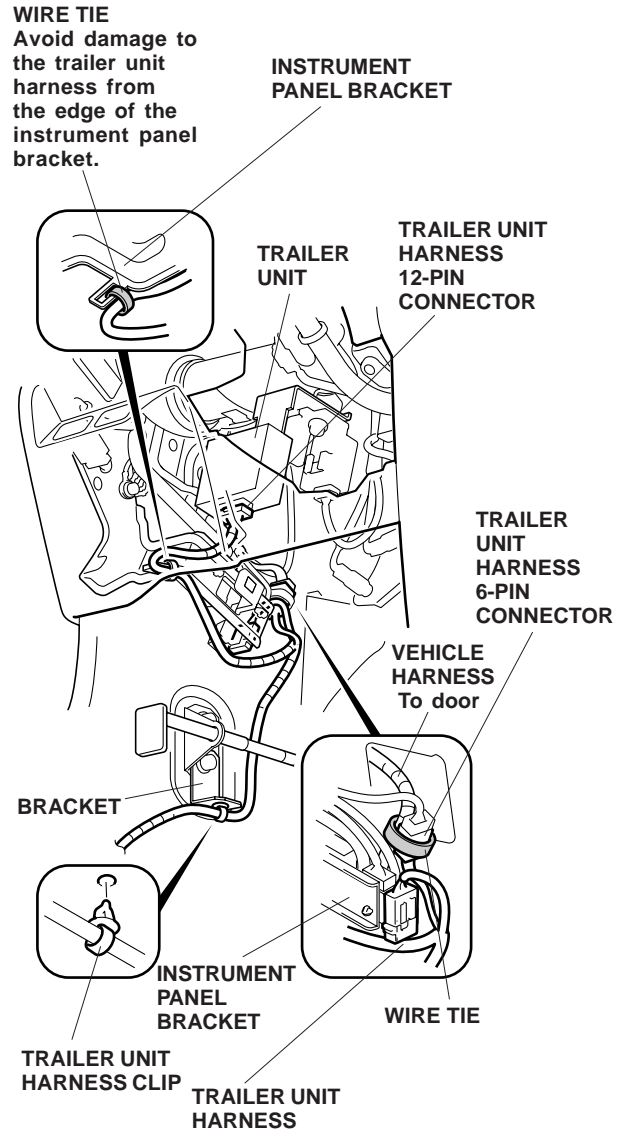

23. Insert the trailer unit harness clip into the hole in the bracket. Secure the 6-pin connector connected in step 19 to the vehicle harness with one wire tie.

24. Route the trailer unit harness on top of the left side step of the vehicle. Turn up the floor carpet. Remove the blue tape to free the 3-pin connector of the vehicle harness, and remove the dummy connector from the vehicle 3-pin connector. Install a wire tie with clip to the vehicle 3-pin connector.

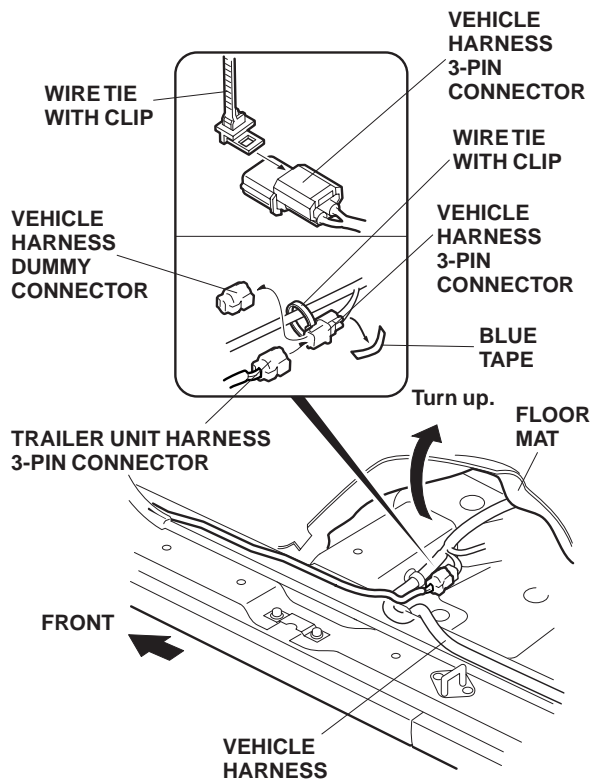

25. Connect the 3-pin connector of the trailer unit harness to the vehicle 3-pin connector. Then secure the trailer unit harness to the vehicle harness with the wire tie with clip installed in step 23.

26. Measure the dimensions with the side step holes as reference, and secure the harness with two cushion tapes as shown.

- Moisten a shop towel with isopropyl alcohol and clean the surface where the cushion tape will attach.

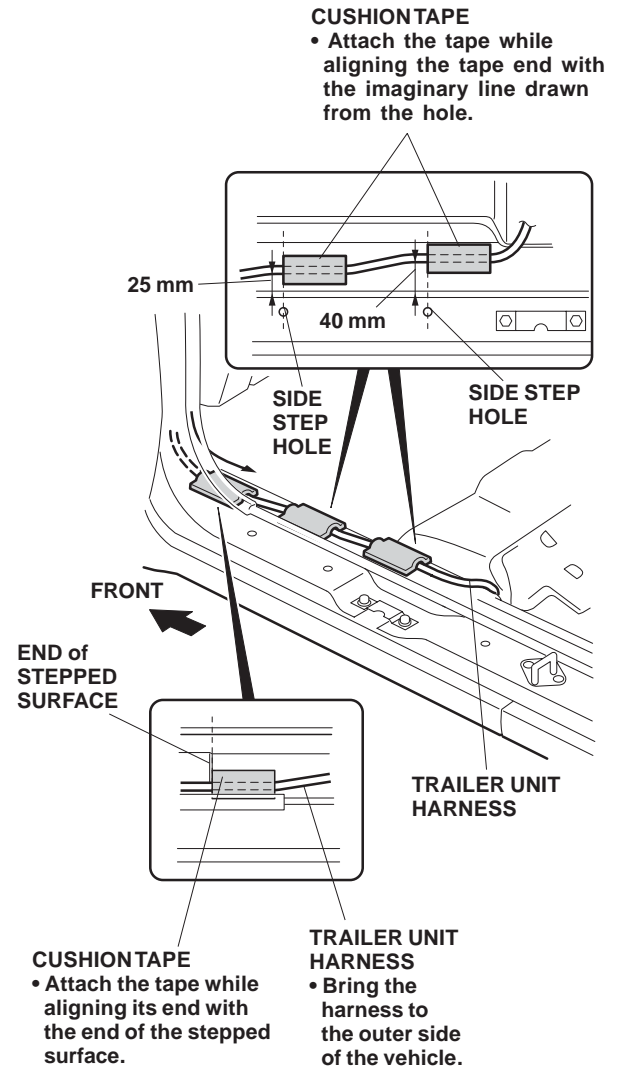

27. Bring the trailer harness to the outer side of the vehicle. Secure the trailer harness with the cushion tape while aligning the end of the tape with the end of the stepped surface of the side step as shown.

- Clean the surface where the cushion tape will be attached with isopropyl alcohol.

27. In the engine compartment, remove the cover from the relay box and install the fuse (7.5 A) included in the kit into the No. 8 slot of the relay box.

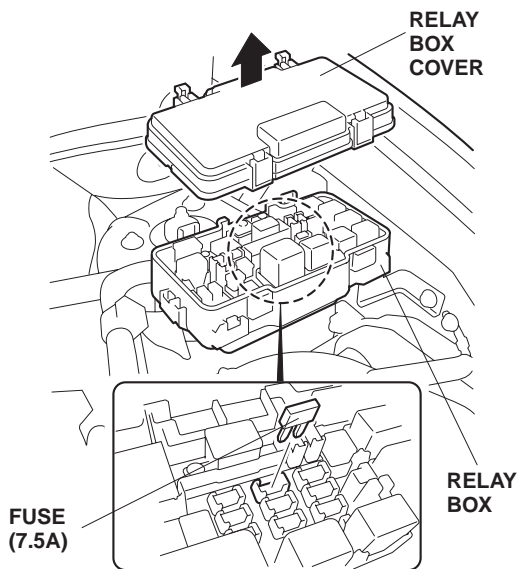

28. Attach the fuse label B (7.5A) over the No.15 on the back of the relay box cover. Reinstall the relay box cover.

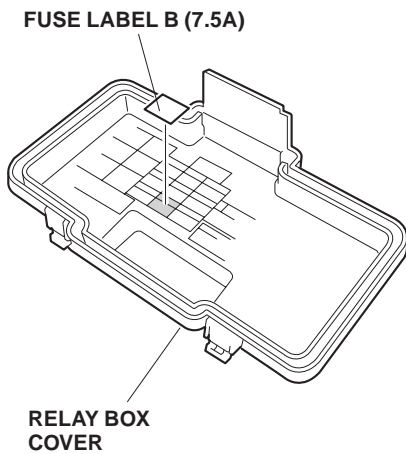

Installing the Trailer Hitch

29. Slide the four 12 x 135 mm bolts into the right and left stays.

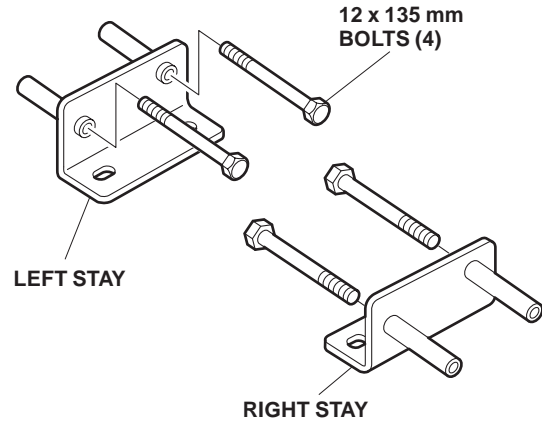

30. From the inboard side of the vehicle frame, slide the right and left stays into the right and left rear frame rails.

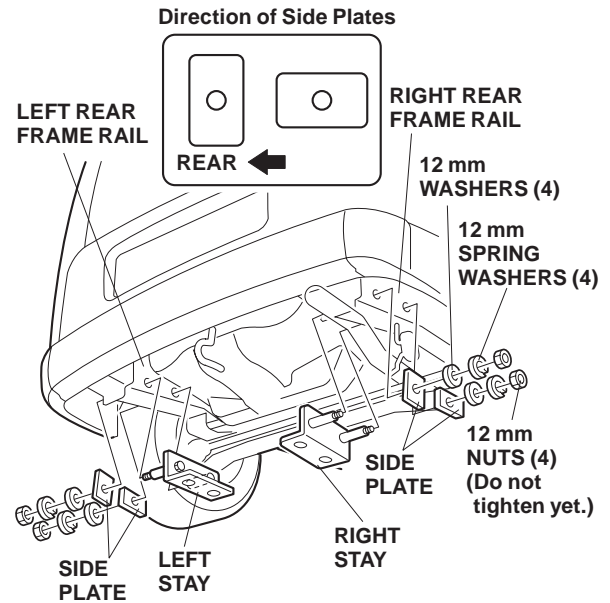

31. From the outboard side, slide the side plates onto the 12 x 135 mm bolts in the direction shown, then install the four 12 mm washers, four 12 mm spring washers and four 12 mm nuts on the ends of the 12 x 135 mm bolts. Do not tighten the nuts yet.

32. With the help of an assistant, position the trailer hitch on the right and left stays and align the holes. Install the four 12 x 35 mm bolts, eight 12 mm washers, four 12 mm spring washers and four 12 mm nuts, but do not tighten the bolts yet.

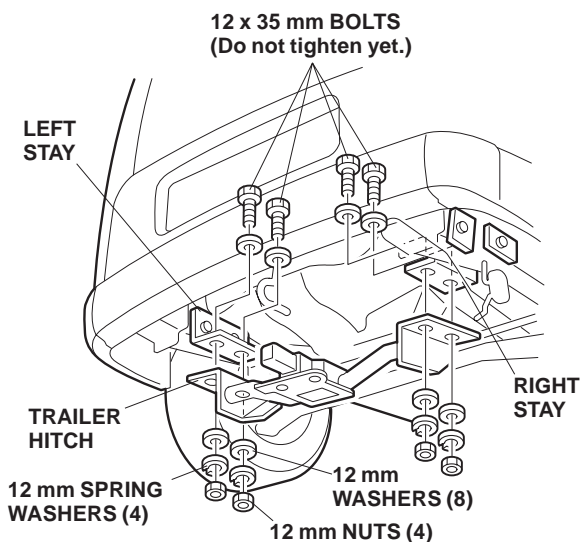

33. Insert the U-bolt around the tie-down hook and into the holes in the plate. Install an 8 mm washer, an 8 mm spring washer and an 8 mm nut on each end. But do not tighten the nuts yet.

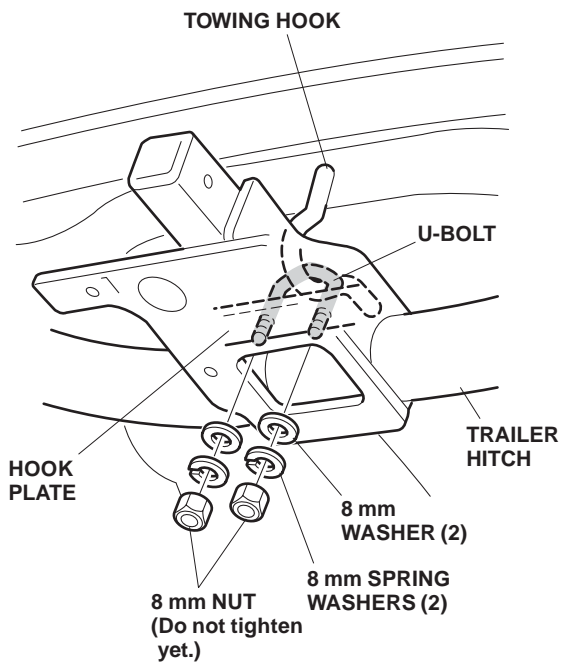

34. Torque all bolts and nuts to their specified torques in the order of 1, 2 and 3.

1

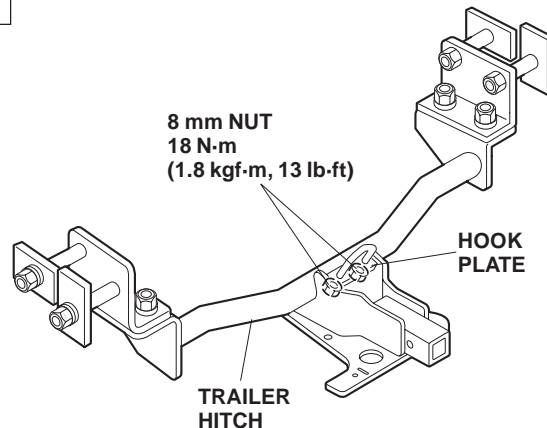

2

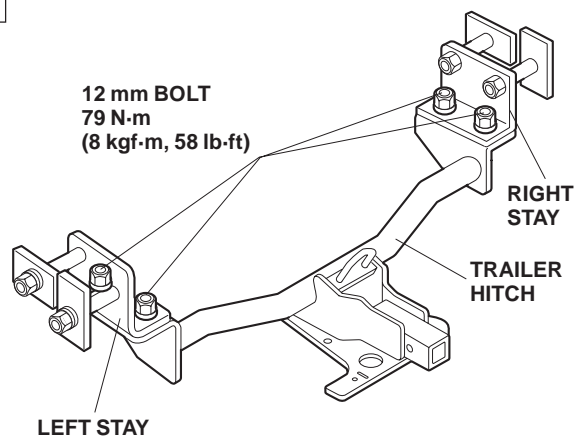

3

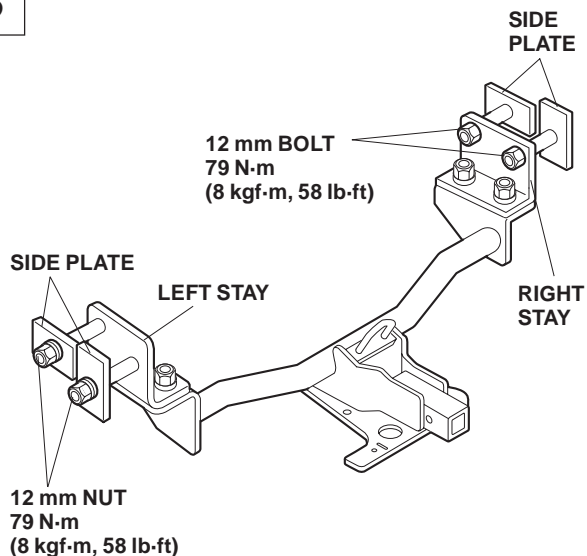

35. Slide the ball mount into the trailer hitch. Align the holes in the trailer hitch with the holes in the ball mount, then insert the retaining pin into the holes. Secure the retaining pin with the retaining clip.

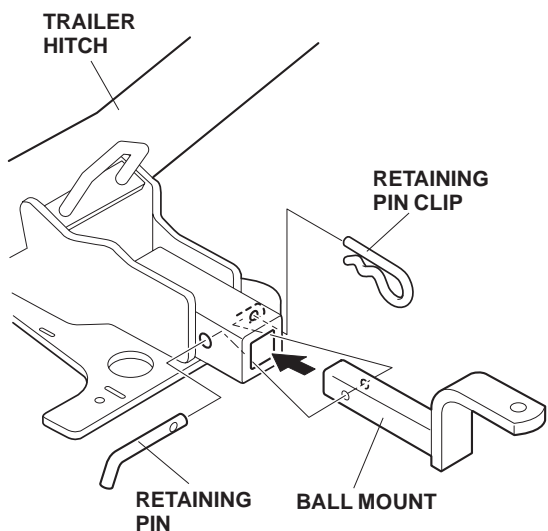

36. Route the trailer harness 4-pin connector to the hitch plate along the trailer hitch.

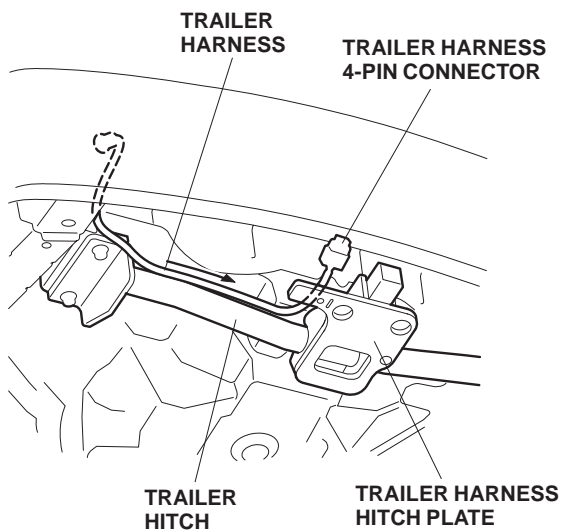

37. Install the connector bracket on the trailer harness 4-pin connector, and secure them to the trailer hitch with the flange bolt and flange nut.

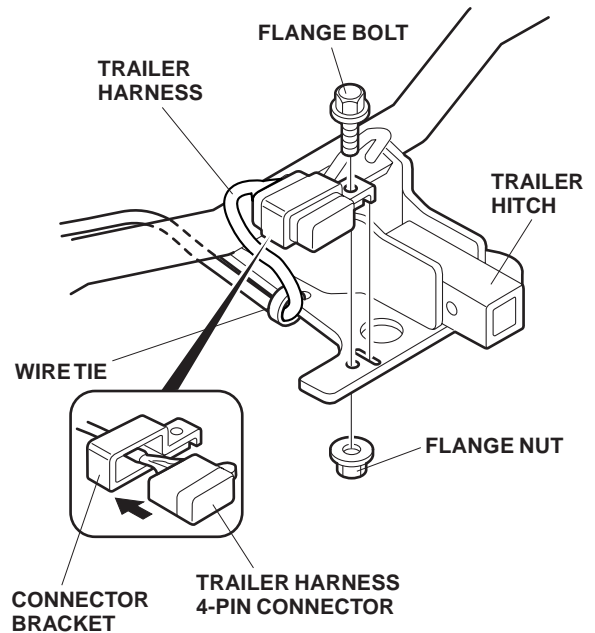

38. Secure the trailer harness to the trailer hitch with one wire tie.
39. Secure the trailer harness to the trailer hitch and to the vehicle panel with four wire ties in the areas shown.

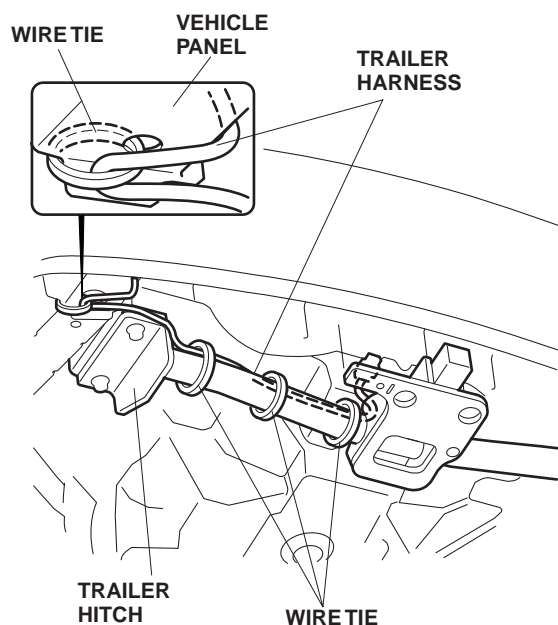

40. Check that all wire harnesses are routed properly and all connectors are plugged in.
41. Reconnect the negative cable to the battery.
42. Enter the customer's radio anti-theft code, and reset the radio station presets.
43. Reset the clock.
44. Reinstall all removed parts. Torque the seat mounting bolts to 32 - 38 N·m (23 - 27 lb·ft)

NOTE: Whenever the battery is disconnected, the driver's window AUTO function is disabled.

45. Start the engine. Push down on the driver's window switch until the window is fully open.
46. Pull up on the driver's window switch to close the window completely, then hold the switch for 2 seconds or more.
47. Lower and raise the window to check operation of the driver's window AUTO function.

NOTE: After about 620 miles (1,000 km) of use, retighten the bolts and nuts to the specified torque.

Put a Copy of This Page in the Glove Box for Your Customer

Installing the Receiver Cover

Whenever you remove the retaining pin clip, the retaining pin, and the ball mount, securely store them in the cargo area. Then press the receiver cover into the opening at the end of the trailer hitch. When you reinstall the ball mount, store the receiver cover in the cargo area.

