



# INSTALLATION INSTRUCTIONS

Accessory  
**SIDE STEP**  
 P/N 08L33-SCV-101

Application  
**2008 ELEMENT**  
 (EXCEPT SC)

Publications No.  
**All 36562**

Issue Date  
**MAY 2007**

## PARTS LIST

Left side step

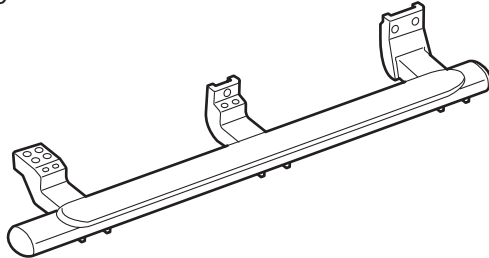

Right side step

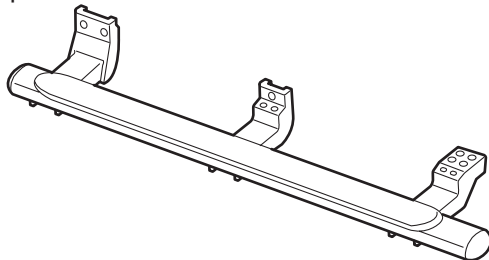

2 Brackets

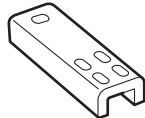

20 Flange bolts



4 Plate bolts

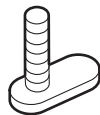

8 Small flange nuts



4 Large flange nuts



4 Plastic washers



2 Washers



## TOOLS REQUIRED

- Ratchet
- 13 mm and 18 mm Combination wrench
- 13 mm and 18 mm Socket
- Torque wrench

## INSTALLATION

**Customer Information:** The information in this installation instruction is intended for use only by skilled technicians who have the proper tools, equipment, and training to correctly and safely add equipment to your vehicle. These procedures should not be attempted by "do-it-yourselfers."

NOTE: Be careful not to damage the body paint finish.

- Position one bracket on the left front side step holder, and install four flange bolts with four small flange nuts. Do not tighten the flange bolts yet.

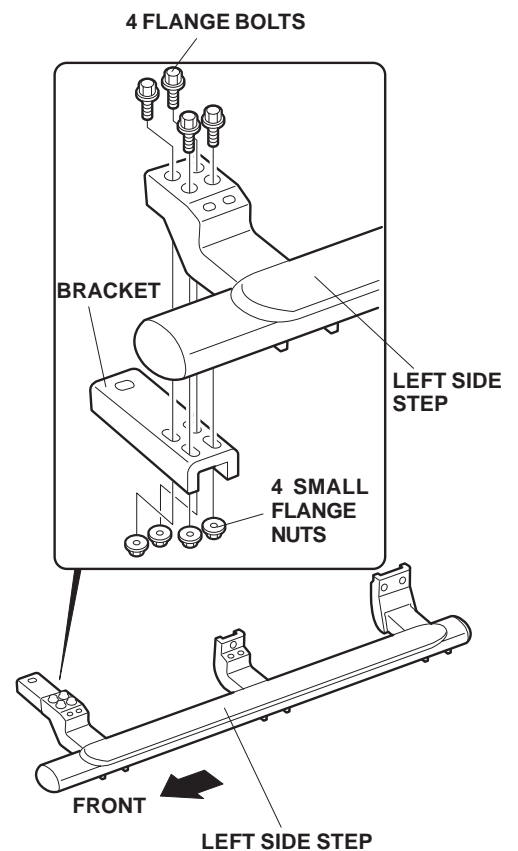

2. Install one plastic washer halfway onto each plate bolt.

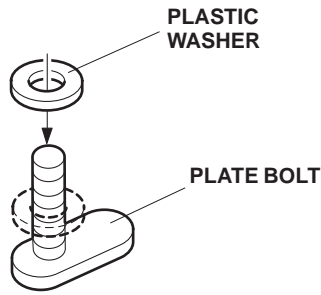

3. Insert the head of the plate bolt into the frame hole as shown. Hold the bolt by the threads and rotate it into position, then push the plastic washer against the frame. Install the other plate bolt the same way.

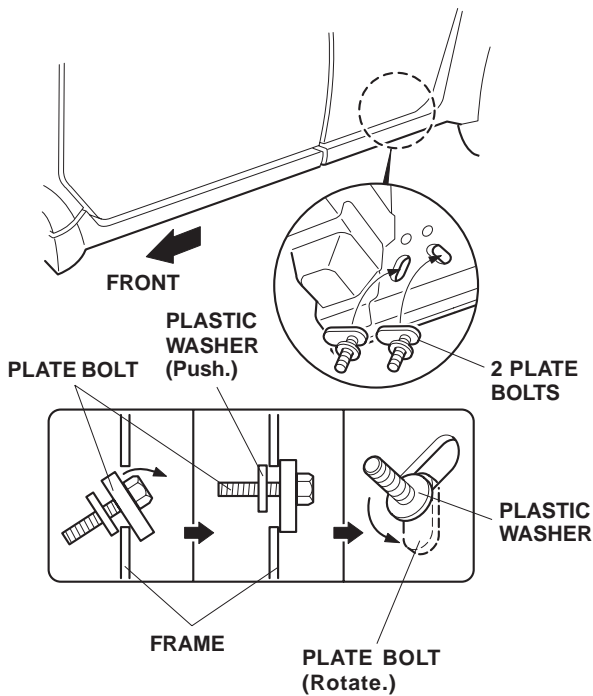

4. Position the left side step on the body and install six flange bolts, one washer, and two large flange nuts.

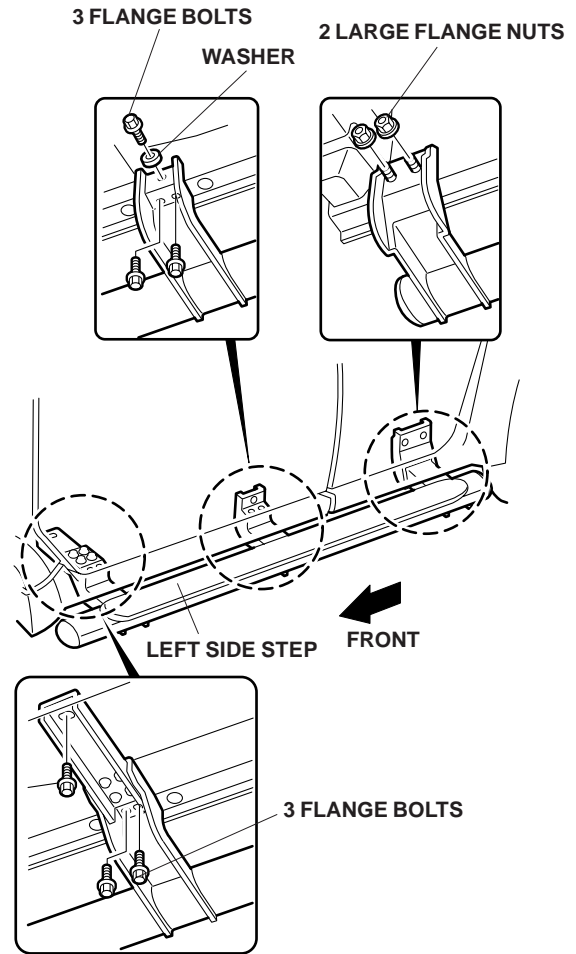

5. Torque the small flange nuts, installed in step 1, to 21 N·m (15 lbf-ft).
6. Torque the large flange nuts and bolts to 21 N·m (15 lbf-ft).
7. Repeat steps 1 thru 6 to install the right side step.