



INSTALLATION INSTRUCTIONS

Accessory	Application	Publications No.
FOG LIGHTS	ELEMENT	All 24288
		Issue Date
		DEC 2002

PARTS LIST

Fog Light Kit [REDACTED]
P/N 08V31-SCV-100

2 Fog lights

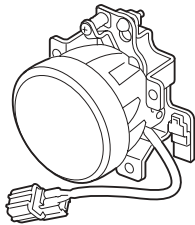

Switch harness

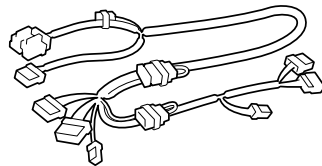

Fog light harness

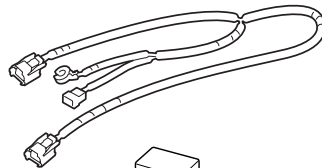

Relay

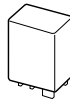

Fuse label

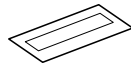

20 Wire ties

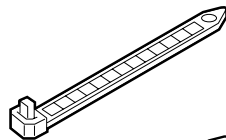

13 Wire ties with clip

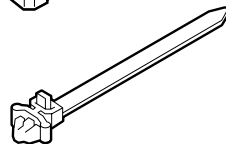

8 Self-tapping screws



Fog Light Switch Kit [REDACTED]
P/N 08V31-SCV-110A (black)
P/N 08V31-SCV-120A (gray)

Switch

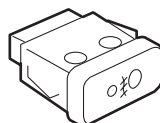

TOOL AND SUPPLIES REQUIRED

- Phillips screwdriver
- Flat-tip screwdriver
- Ratchet
- 10 mm socket
- File
- Drill
- 3 mm and 20 mm Drill bits
- Utility knife
- Diagonal cutters
- Pushpin
- Hacksaw blade
- Clip remover

Illustration of the Fog Lights Installed on the Vehicle

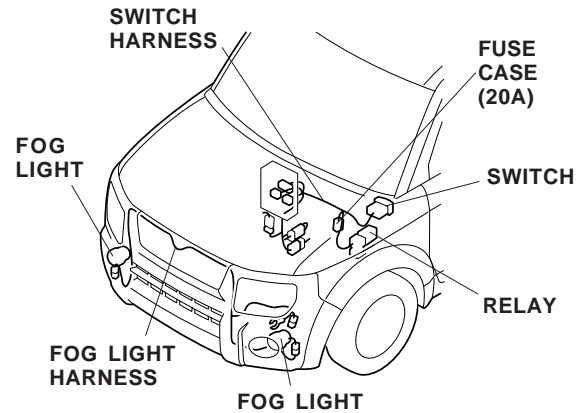

INSTALLATION

Customer Information: The information in this installation instruction is intended for use only by skilled technicians who have the proper tools, equipment, and training to correctly and safely add equipment to your vehicle. These procedures should not be attempted by “do-it-yourselfers.”

NOTE: This installation instruction shows the left fog light being installed; the same procedure applies to installing the right fog light.

1. Make sure you have the anti-theft code for the radio, then write down the frequencies for the preset buttons.
2. Disconnect the negative cable from the battery.

Installing the Fog Light

- Open the hood and remove the radiator cover (five clips).

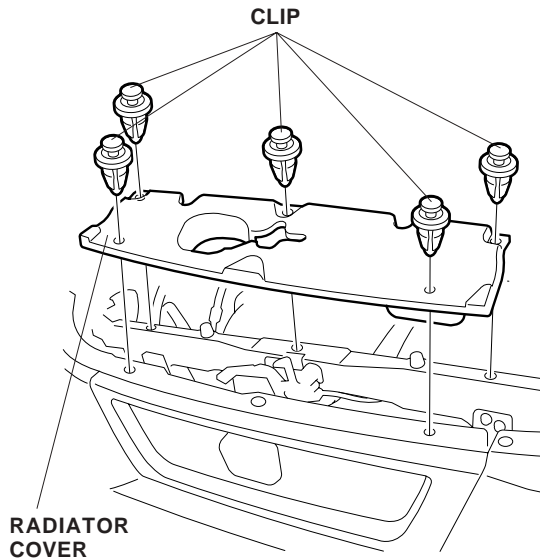

- Remove the front bumper (seven clips at the top, six clips and four stepped bolts at the bottom and one self-tapping screw on each side).

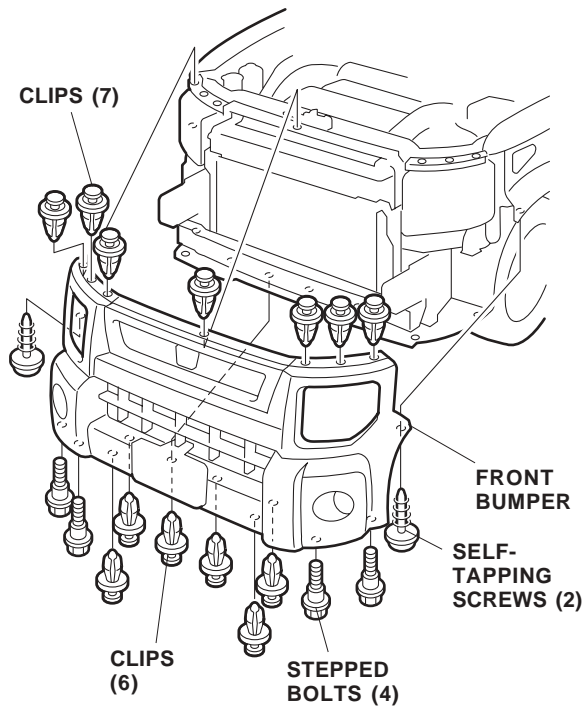

- Inside the front bumper, locate the three marks on the fog light housing, on the left side. Using a pushpin, pierce the bumper at the center of each mark. While wearing eye protection, drill a 3 mm pilot hole then finish with a 20 mm hole through the bumper at the center of each mark.

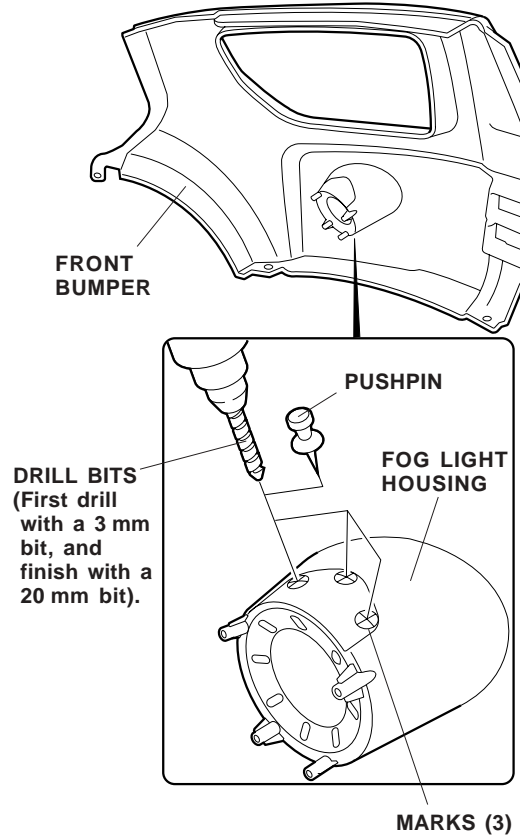

- While being careful not to scratch the bumper, use a hacksaw blade to cut out the marked area from the front bumper along the inside of the scribed line and the groove on the back. Remove all burrs from the edges of the cutout.

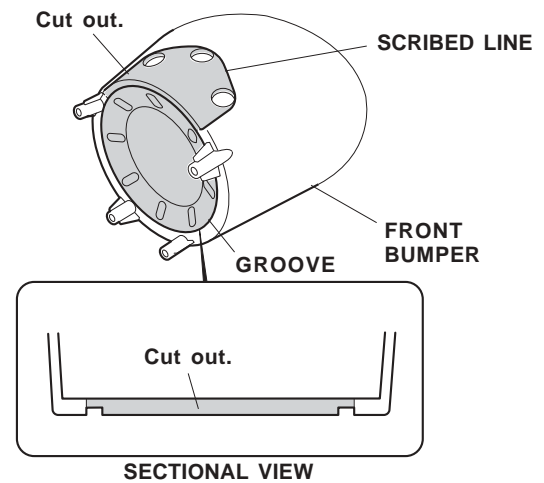

7. Inside the front bumper, slide the fog light into the cutout you made, and secure it with four self-tapping screws.

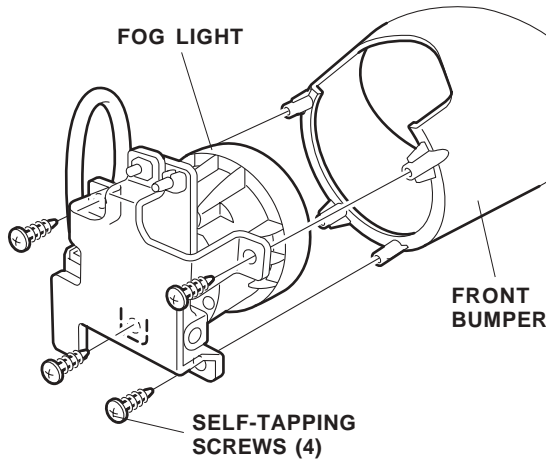

8. Repeat steps 5 thru 7 to cut the bumper and install the fog light on the right side of the bumper.

Routing the Fog Light Harness

9. Starting under the left headlight, route the fog light harness 1-pin connector and ground terminal through the hole in the front bulkhead.

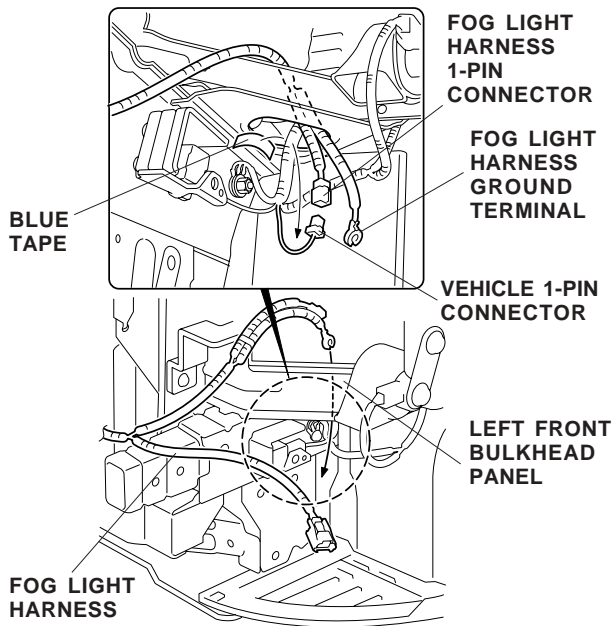

10. Locate the 1-pin connector blue-taped to the vehicle harness and remove the blue tape to free the 1-pin connector. Connect the 1-pin connector you just freed to the fog light harness 1-pin connector.

11. Loosen the ground bolt that fastens the vehicle ground terminal and secure the fog light harness ground terminal using this ground bolt.

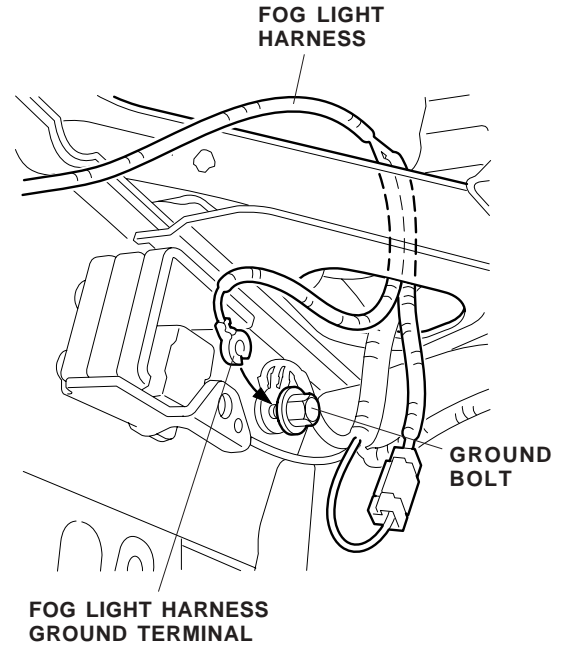

12. Secure the fog light harness 1-pin connector and the fog light harness to the vehicle harness with one wire tie. Do not secure the 1-pin connector to the SRS harness with the wire tie.

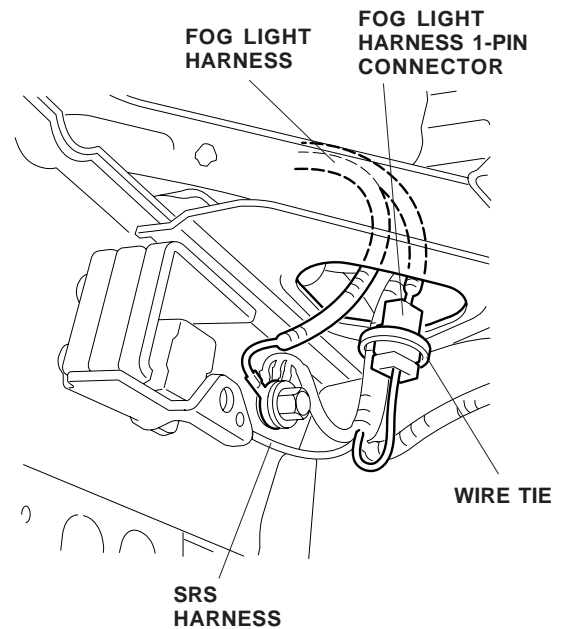

13. Behind the front side frame, route the fog light harness 2-pin connector (short end) down, and out through the clearance between the side frame and front bumper beam. Attach the wire tie with clip to the fog light harness at the green tape, then push the clip into the hole in the side frame.

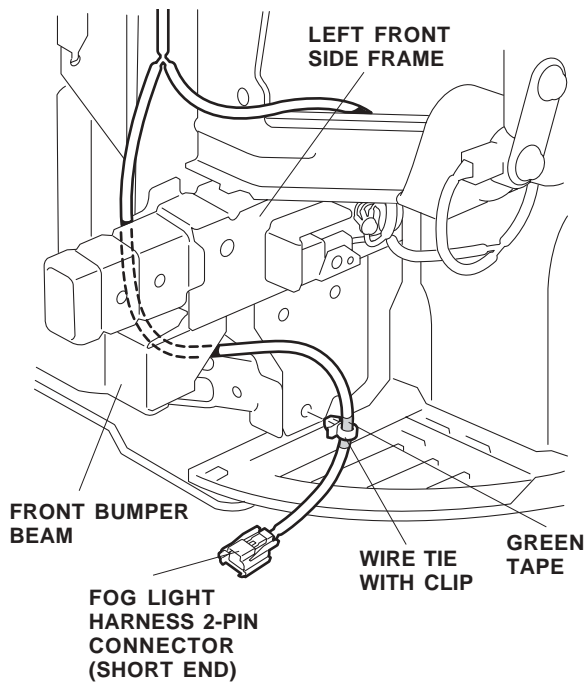

14. Route the fog light harness 2-pin connector (long end) up along the bulkhead side stay, then along the vehicle harness behind the front bulkhead upper frame.

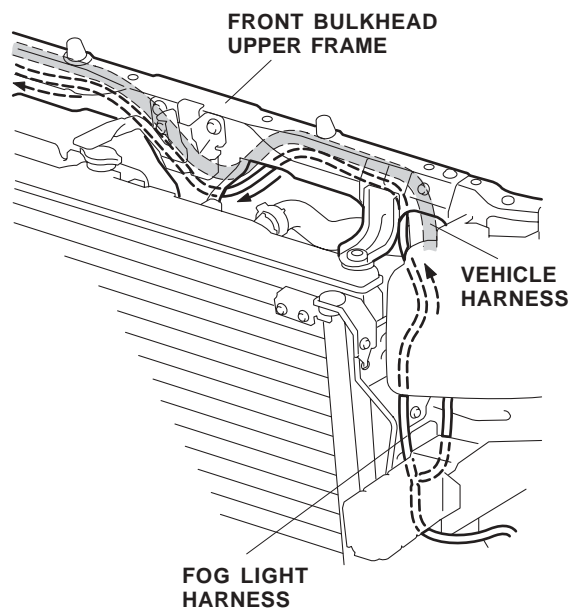

15. Continue routing the fog light harness 2-pin connector forward, then down to the bottom of the front side frame along the outside of the right bulkhead side stay.

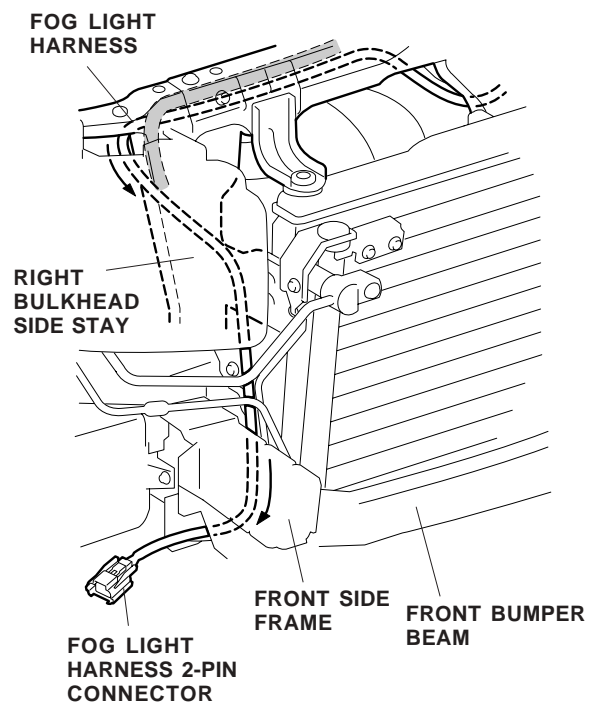

16. Align the green tape on the fog light harness (closest to the connector) with the hole in the front lower cross member, then secure the harness to the hole with the wire tie in the area shown.

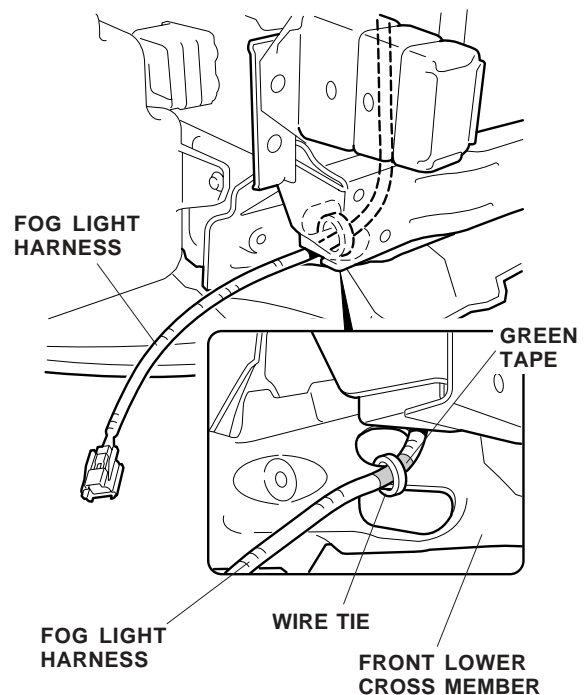

- Attach the three wire ties with clips to the fog light harness at the green tapes, then push the clips into the holes in the bulkhead side stay. Further secure the fog light harness to the vehicle harness with two wire ties in the areas shown.

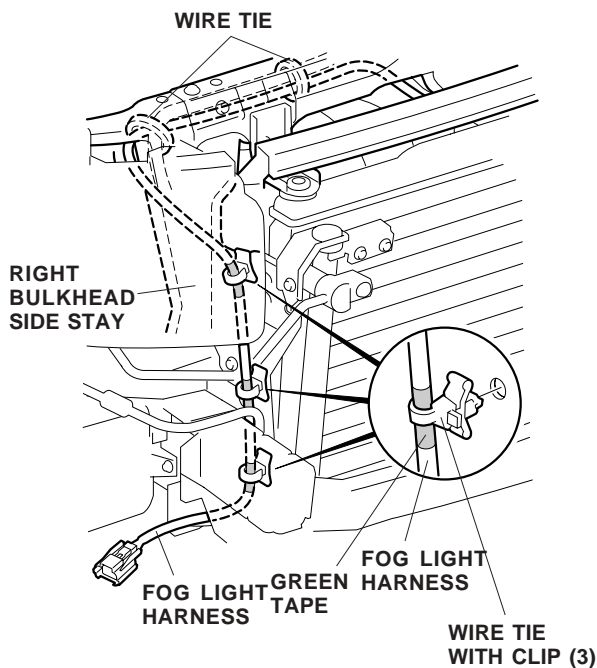

If the vehicle is equipped with an engine block heater:

Secure the engine block heater and fog light harnesses to the bulkhead side stay with the wire ties on the engine block heater harness and two wire ties with clips on the fog light harness.

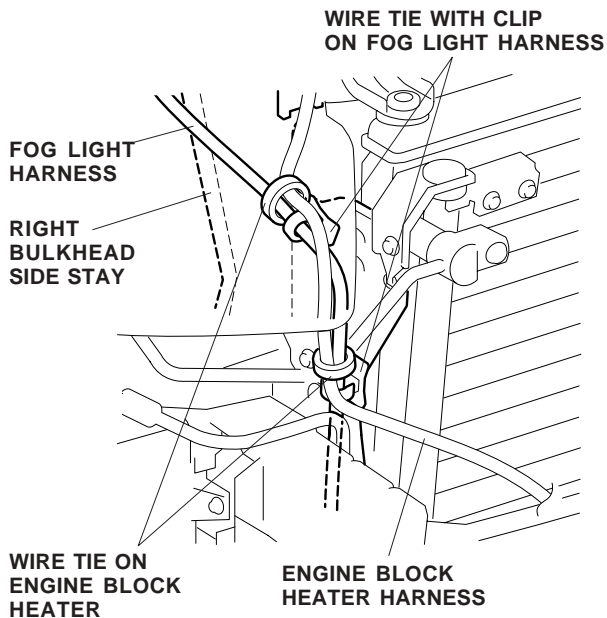

- Secure the fog light harness to the vehicle harness with six wire ties in the areas shown.

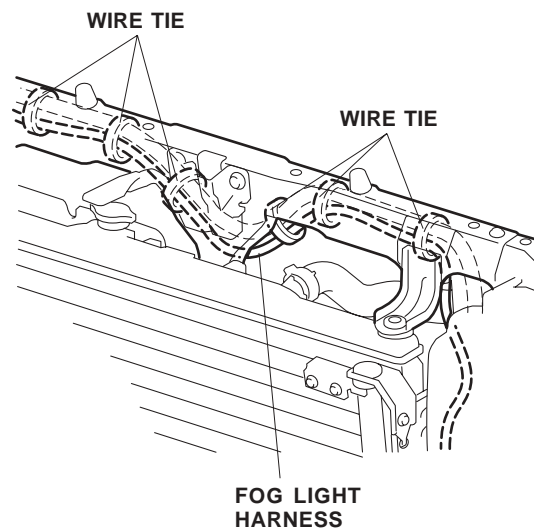

- Secure the fog light harness to the holes in the bulkhead side stay and the side frame with four wire ties with clip.

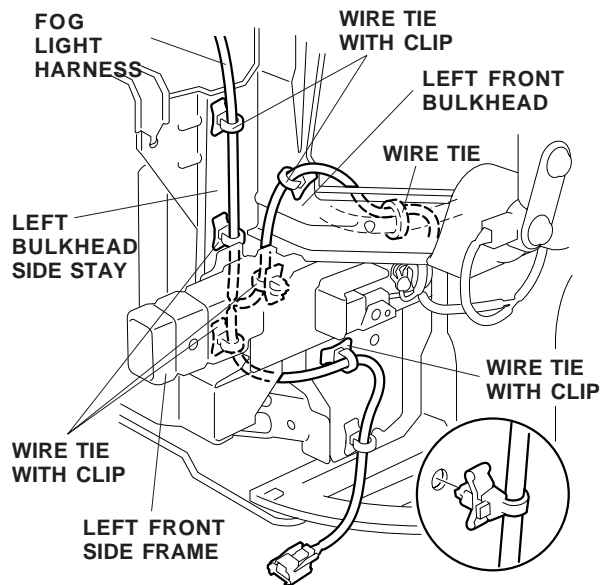

- Secure the fog light harness to the front bulkhead area with the wire tie with clip, and to the vehicle harness with one wire tie.
- Secure the fog light harness to the hole under the front side frame with one wire tie with clip.

22. While holding the front bumper near the front of the vehicle, plug the fog light harness 2-pin connectors into the 2-pin connectors from the fog lights. Reinstall the front bumper.

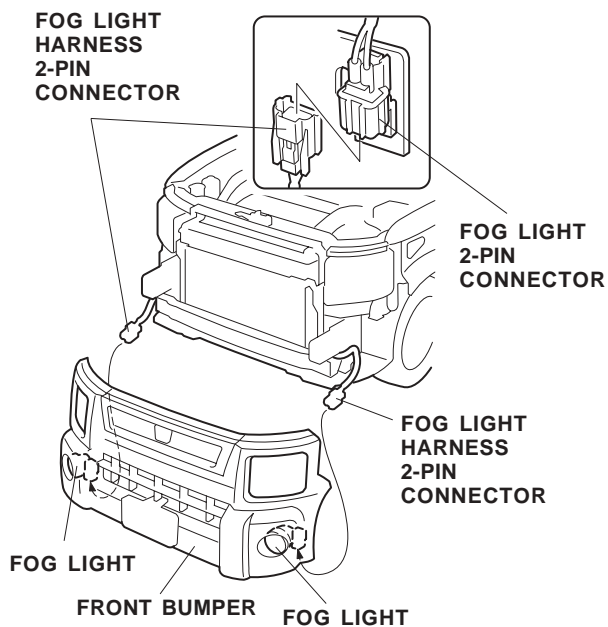

Routing the Switch Harness

23. Remove the driver's dashboard lower cover, turn the knobs clockwise, then pull the cover out toward you to release the six retaining tabs.

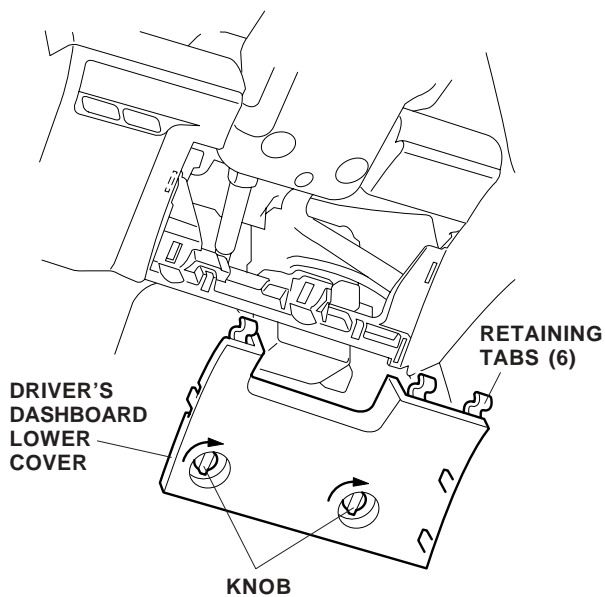

24. Remove the center dashboard lower cover (two expansion clips, two clips and four retaining tabs).

NOTE: This illustration shows the center lower cover with subwoofer. Remove the center lower cover without subwoofer the same way.

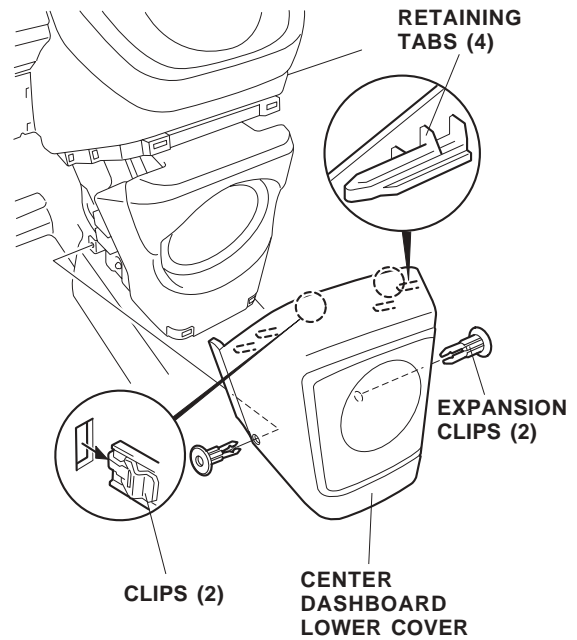

25. Starting from behind the instrument panel, route the switch harness 8-pin connectors down along the vehicle harness. On the left of the instrument panel frame, unplug the vehicle 8-pin connectors (gray), and plug the switch harness 8-pin connectors in between the switch harness connectors and the vehicle connector.

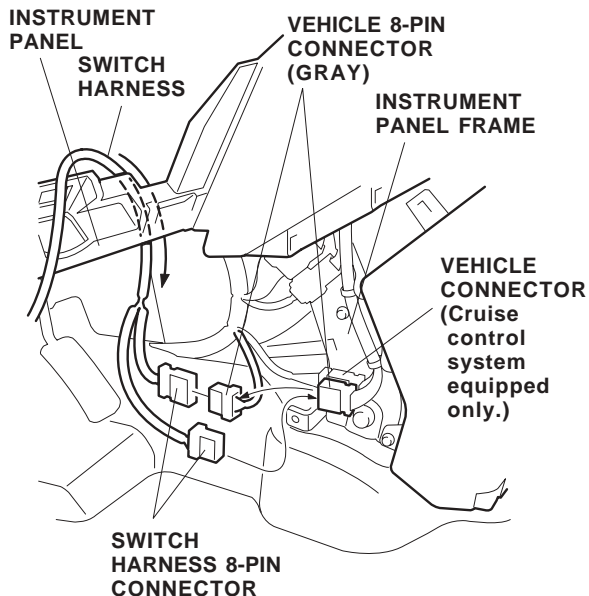

26. Slide the switch harness 8-pin connector onto the holder on the vehicle 8-pin connector (gray).

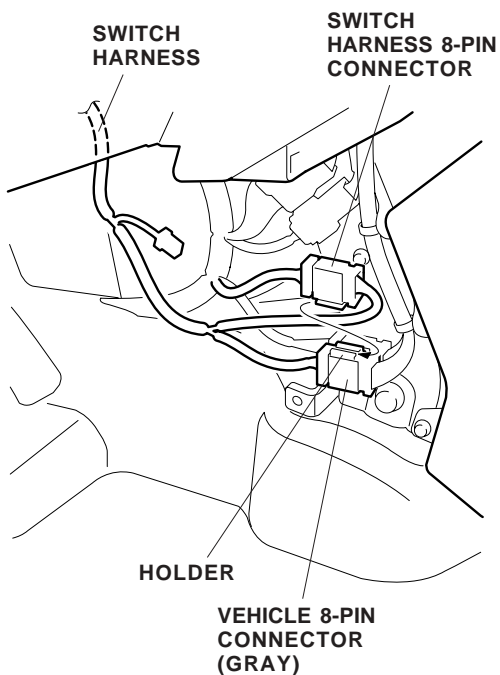

27. Locate the 1-pin connector blue-taped to the vehicle harness and remove the blue tape to free the connector. Plug the vehicle harness 1-pin connector into the switch harness 1-pin connector (blue/red).

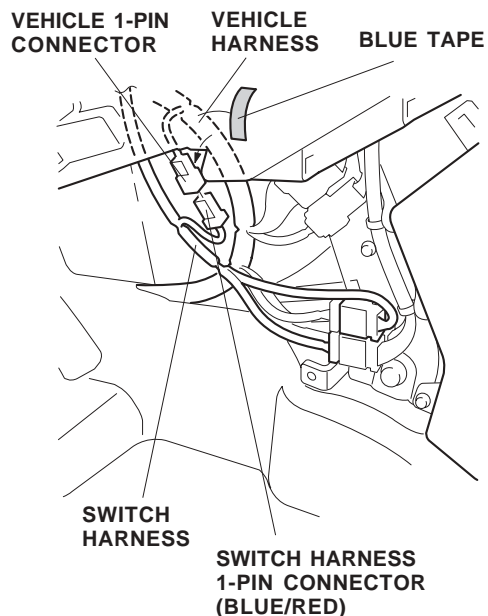

28. At the fuse box, plug the switch harness 1-pin connector (white/red) into the fuse box in the location shown.

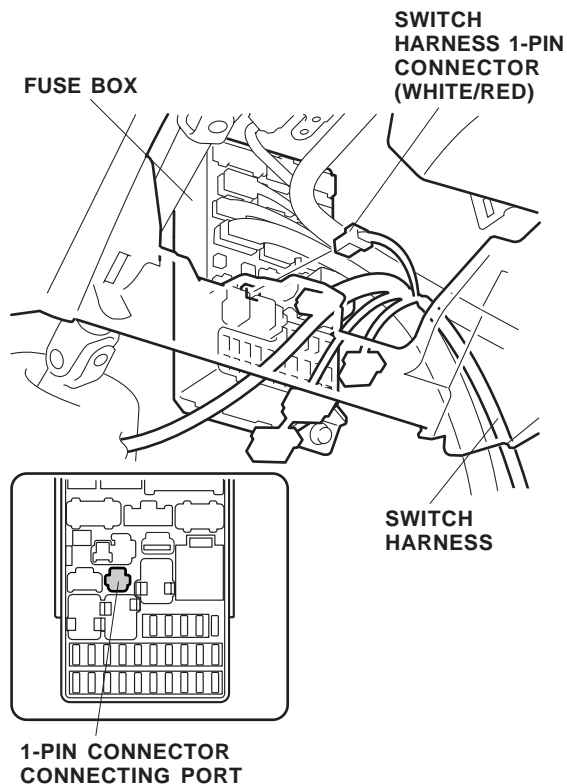

29. *On A/T only:* Unplug the vehicle 6-pin connector from the fuse box. Remove and discard the dummy connector from the 6-pin connector black-taped to the switch harness. Plug the switch harness 6-pin connectors in between the fuse box and the vehicle connector.

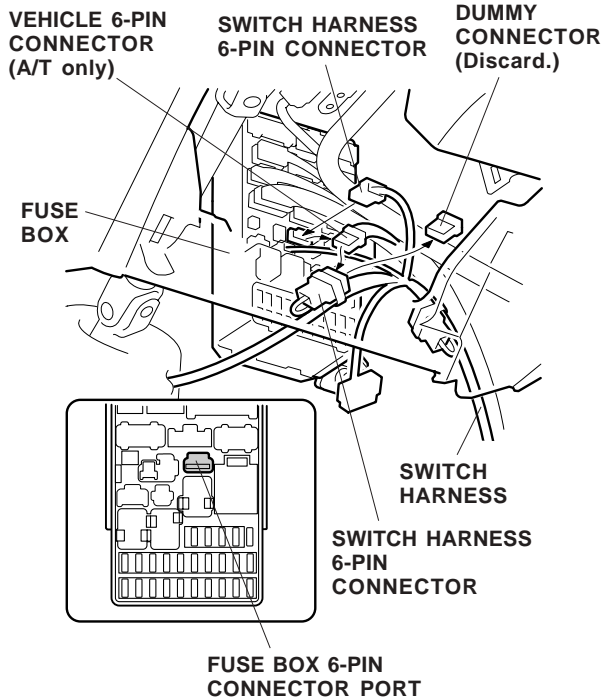

30. *On M/T only:* Plug the switch harness 6-pin connector into the fuse box.

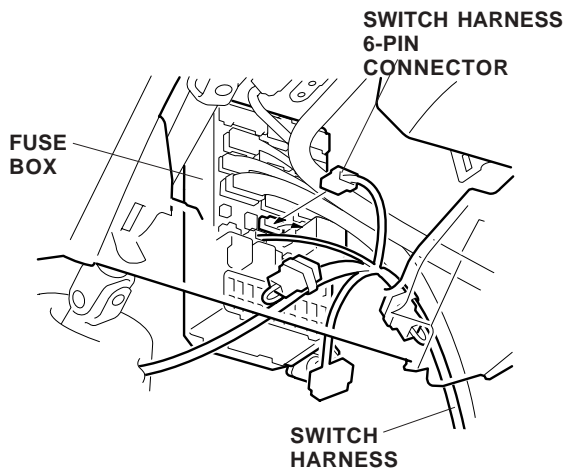

31. Unplug the vehicle 12-pin connector from the fuse box and plug the switch harness 12-pin connectors in between the fuse box and the vehicle connector.

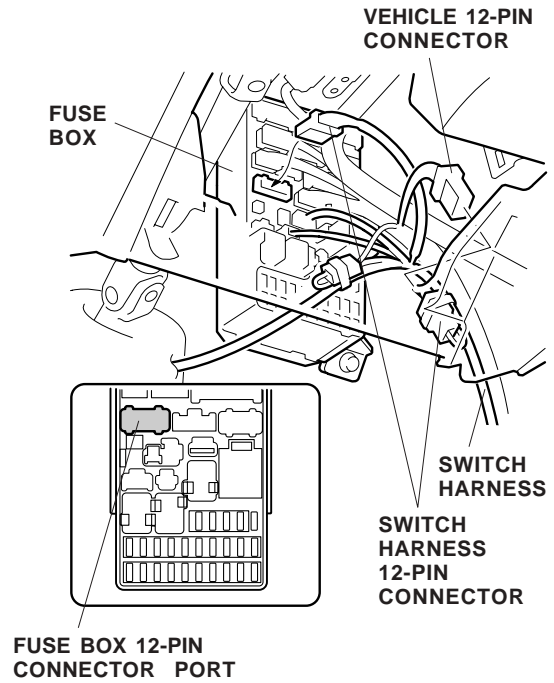

32. Attach the fuse label (20A) to the fuse case on the switch harness.
33. From under the steering shaft, route the switch harness 5-pin connector to the left from behind the knee bolster.

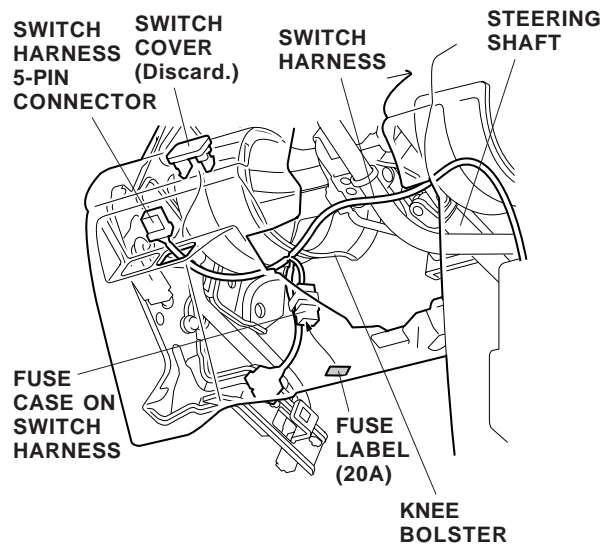

34. Remove the switch cover from the instrument panel, and pull the switch harness 5-pin connector out through the hole.

35. Plug the relay into the switch harness relay block, then slide the relay block onto the instrument panel bracket stay.

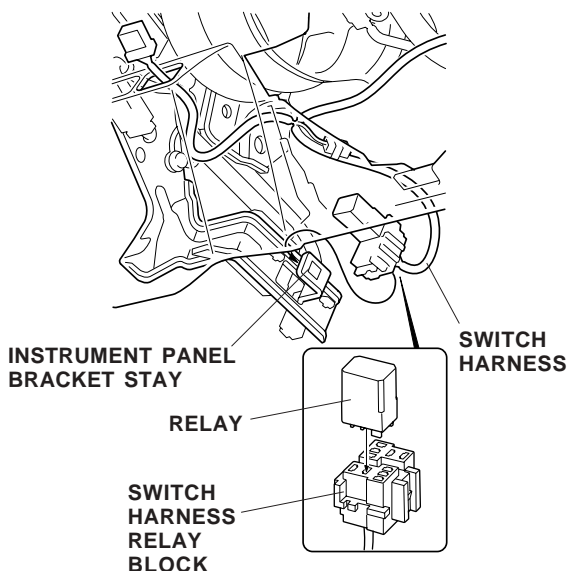

36. Align the green tape on the switch harness with the vehicle harness clip, then secure the switch harness to the vehicle harness with the three wire ties in the areas shown.

NOTE: If the vehicle is not equipped with a cruise control switch, attach the wire tie with clip to the switch harness. Push the switch harness clip from the wire tie with clip into the hole in the instrument bracket.

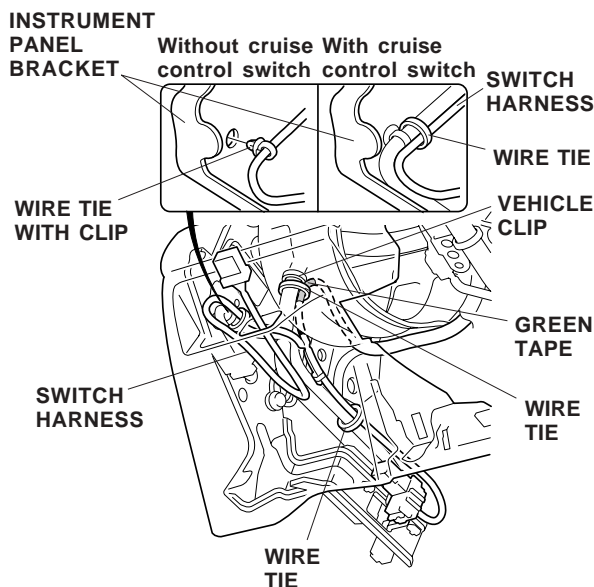

37. Attach a wire tie with clip to the switch harness at the green tape, then push the clip into the hole in the steering hanger lower bracket.

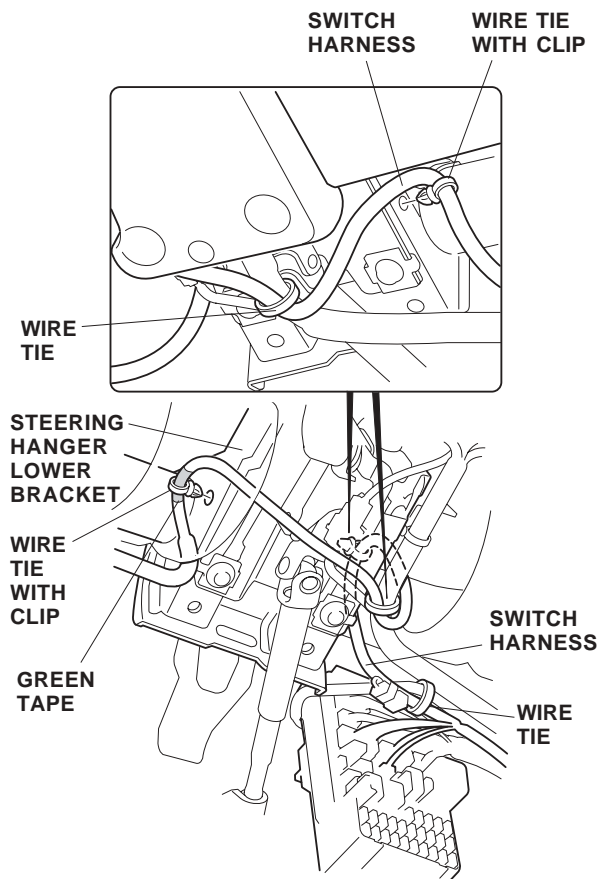

38. Secure the switch harness to the vehicle harness and to the hole in the steering hanger lower bracket with two wire ties and one wire tie with clip. Move the steering wheel up and down to confirm that the switch harness is not being pulled. Readjust if necessary.

39. Secure the switch harness to the vehicle harness with two wire ties in the areas shown.

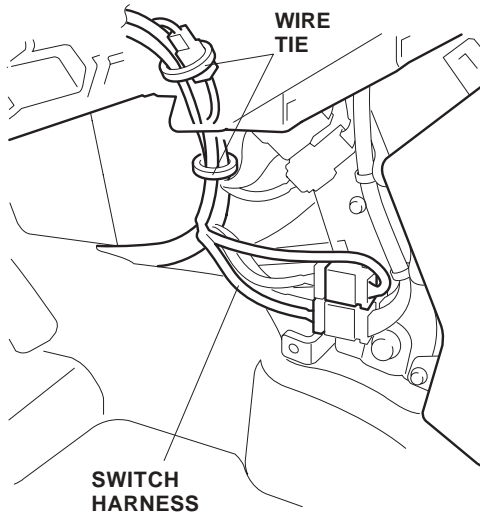

40. Plug the switch harness 5-pin connector (blue) into the switch, then install the switch in the hole in the instrument panel.

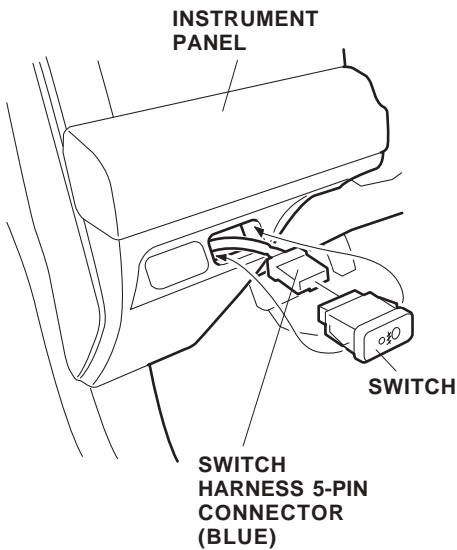

41. Check that all wire harnesses are routed properly and all connectors are plugged in.
42. Reinstall all removed parts. Check that all clips and fasteners are installed securely.
43. Reconnect the negative cable to the battery.
44. Reset the clock, and reset the radio station presets.

NOTE: Whenever the battery is disconnected, the driver's window AUTO function is disabled.

45. Start the engine. Push down on the driver's window switch until the window is fully open.
46. Pull up on the driver's window switch to close the window completely, then hold the switch for 2 seconds.
47. Lower and raise the window to check the operation of the driver's window AUTO function.

USE AND CARE

How to Operate Fog Lights

- Turn the light switch to the "FOG" position (headlights on low beam).
- Press the fog light switch (indicator is on).

The fog light lenses can cloud when the outside temperature is cold; this is a normal condition.

Fog Light Aiming Adjustment

- Adjust the aiming according to local laws and regulations.
- To adjust, turn the aiming adjustment screw in or out until the correct aiming is obtained.

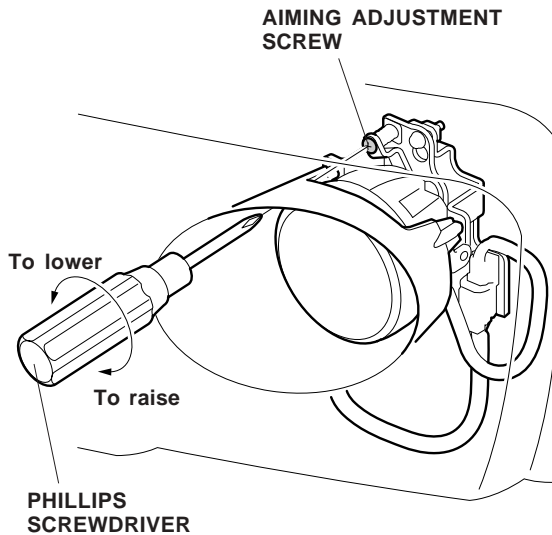

Replacing the Fog Light Bulb

1. Loosen the upper right screw on the fog light. Lift the fog light up, then pull it out toward you.

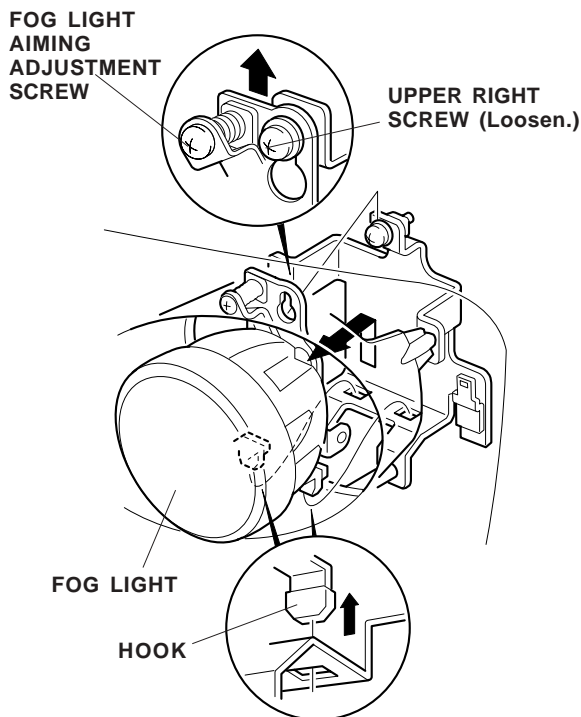

2. Remove the fog light connectors from the bracket stay, then unplug the connectors. Remove the fog light.

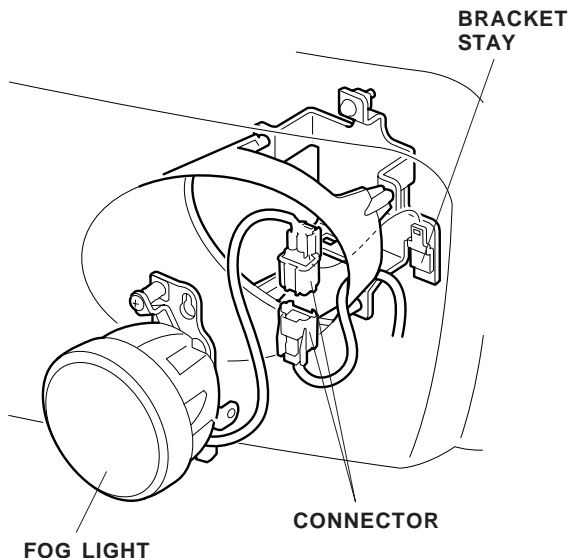

3. Remove the fog light rear cover (five screws).

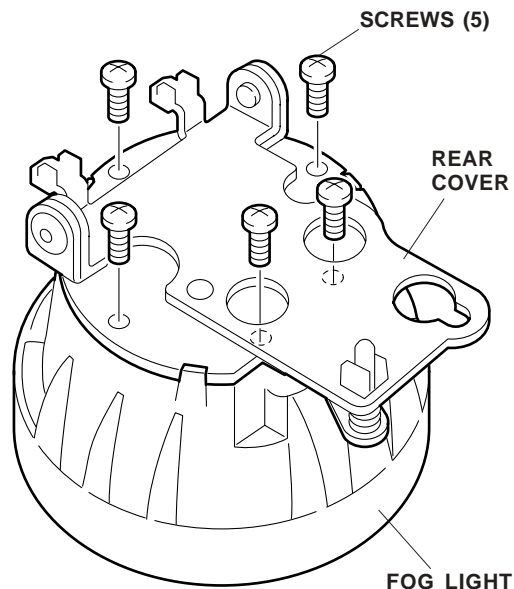

4. Remove the retainer spring, and pull out the bulb and socket as a unit.

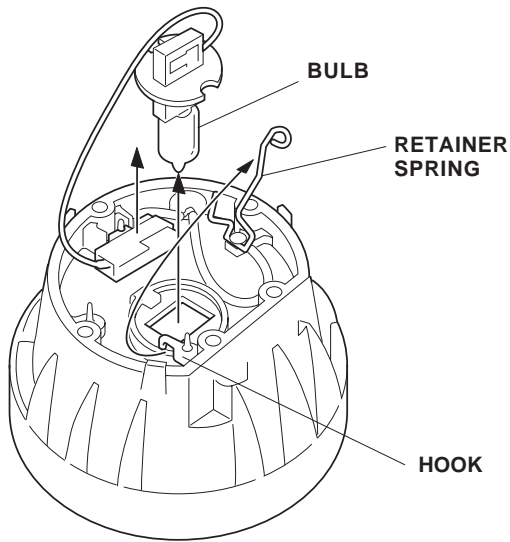

5. Install the new bulb into the socket.

- Use only a genuine Honda halogen light bulb of specified wattage.

Rating: 12V 55W H3 Halogen Light Bulb
P/N 33165-SB0-7310-M1

- Do not touch the bulb. Oily or greasy substances on the bulb can shorten its service life due to the heat produced when the bulb is turned on. If the bulb is accidentally touched, wipe it clean with a soft cloth that has been dampened with denatured alcohol or a mild detergent solution.
- Align the tab on the fog light with the cutout when installing the new bulb. If it is not aligned, the fog light may annoy oncoming drivers.

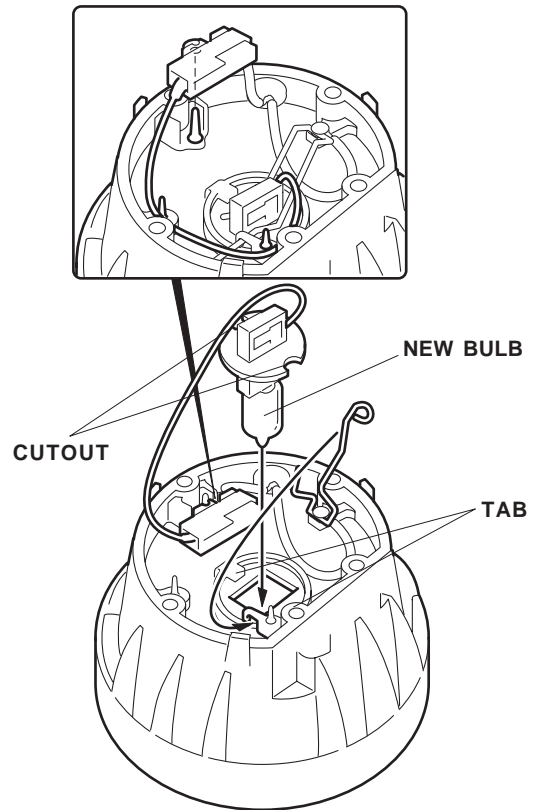

6. Reinstall the removed parts in the reverse order of removal.

- Check that the wire harnesses are not pinched.
- Make sure to tighten the screws securely.

CIRCUIT DIAGRAM

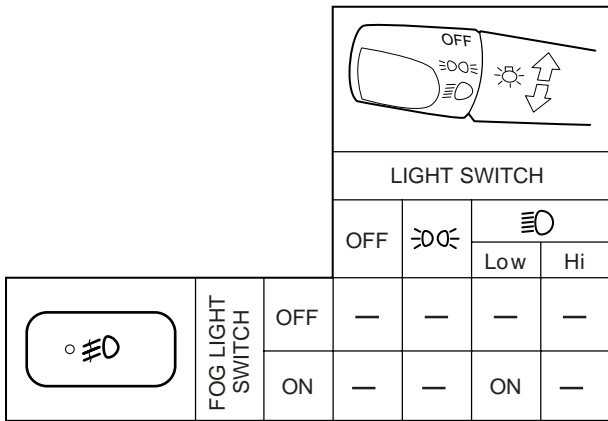
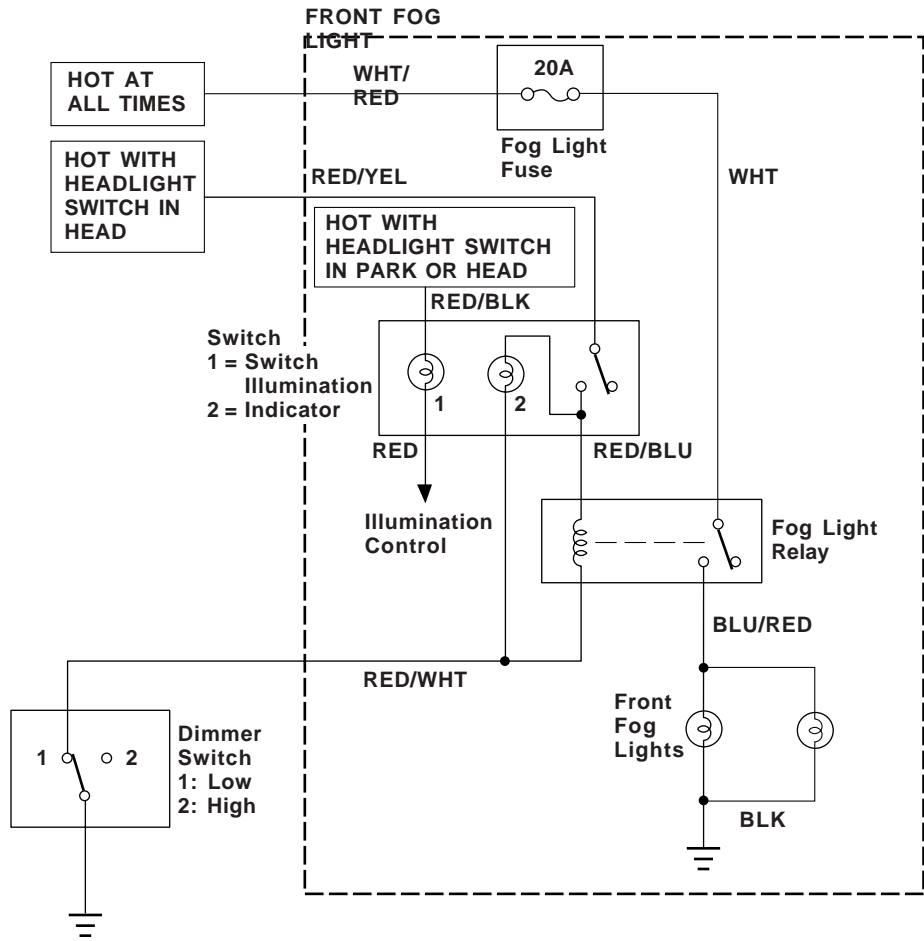

BLK	BLACK	LT BLU	LIGHT BLUE
YEL	YELLOW	BRN	BROWN
BLU	BLUE	ORN	ORANGE
GRN	GREEN	PNK	PINK
RED	RED	GRY	GRAY
WHT	WHITE	LT GRN	LIGHT GREEN