



INSTALLATION INSTRUCTIONS

Accessory

SKI ATTACHMENT
P/N 08L03-TA1-100B

Application

ELEMENT

Publications No.

All 36558

Issue Date

MAY 2007

Put this information in the glove box with the vehicle owner's manual.

PARTS LIST

2 Ski attachments

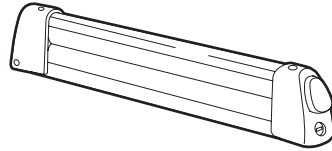

4 Knobs



4 Short T-bolts (not used)

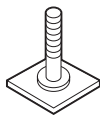

4 Long T-bolts

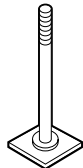

4 Spacers

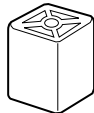

Key



TOOLS AND SUPPLIES REQUIRED

Flat-tip screwdriver

Shop towel

INSTALLATION

NOTE:

- The ski attachments are designed to be used exclusively with a Honda roof rack, which is sold separately. If the vehicle is not equipped with a roof rack, install a roof rack before installing the ski attachment.
- The ski attachments may be installed either with both on the driver's side or with both on the passenger's side.

- Using a flat-tip screwdriver wrapped with a shop towel, push in on the locking tab and remove the roof rack cover. Remove the roof rack cover from the other roof rack the same way.

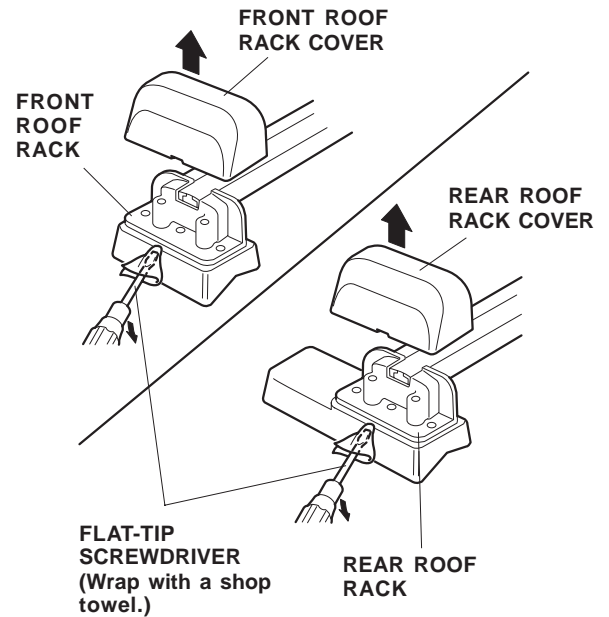

- Remove the rubber moldings from the front and rear roof rack crossbars. Retain the rubber moldings to reinstall if the attachment is removed.

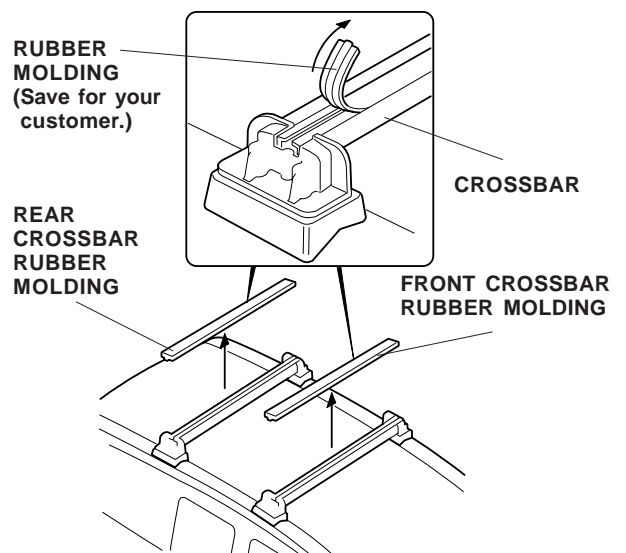

- Slide two long T-bolts into each crossbar.

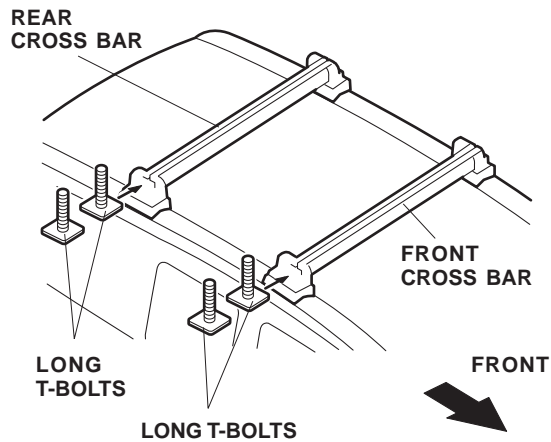

- Reinstall the roof rack cover.
- Insert the key, and turn it clockwise to unlock the front ski attachment. Press the button, and open the top frame completely.

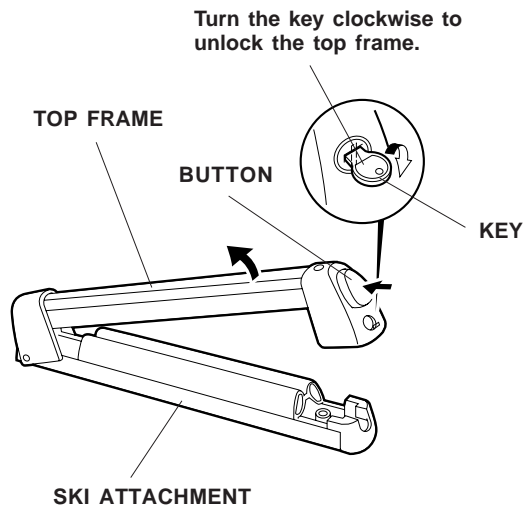

- Position the spacers and the front ski attachment onto the long T-bolts, and install the two knobs. Tighten the knobs securely.

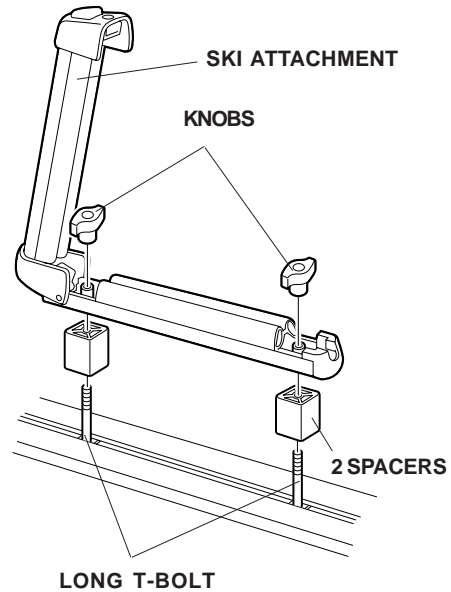

- Repeat steps 5 and 6 to install a ski attachment to the rear crossbar.
- Close the top frame, and listen for it to "click" into position, then turn the key counterclockwise to lock the top frame.
- Rock the ski attachment in all directions to make sure it is installed securely. If necessary, retighten the T-bolts or reinstall the ski attachment.
- Write down the key number, and put the number in the glove box in case the key is lost or stolen.
- Put the rubber moldings removed in step 2 in a clean plastic bag, and put them in the passenger's foot well. Put the keys in the glove box with this instruction and the key number.

Loading Skis on the Attachment

1. Insert the key, and turn it clockwise to unlock the top frame. Push the button, and raise the top frame completely.

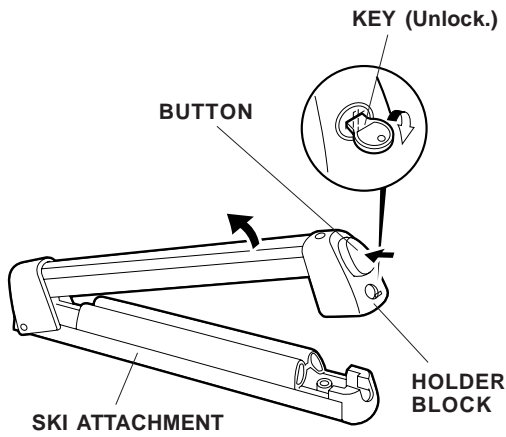

2. Position the skis on the attachment:
 - Load the skis with the rear of the skis facing forward and the bindings between the front and rear attachments.

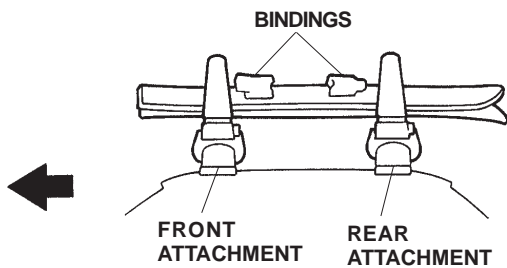

- If the bindings cannot be positioned between the front and rear attachments, install the skis with one of the bindings positioned behind the rear attachment.

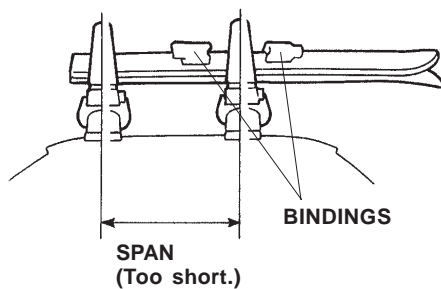

3. Close the top frame, and listen for it to click into position. Depending on the thickness of the ski, you may need to attach the hook in the second position.

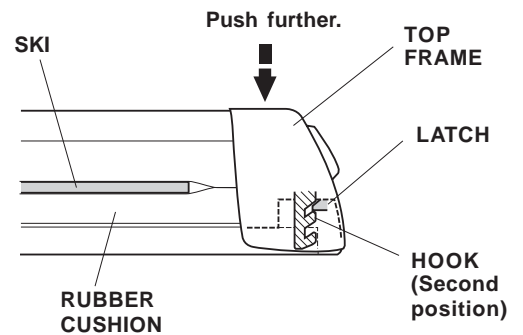
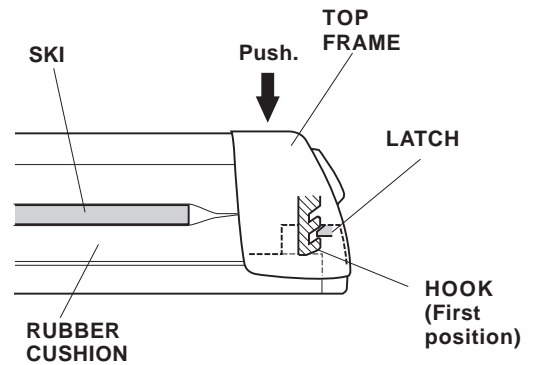

4. Lock the top frame by turning the key counterclockwise. Remove the key.

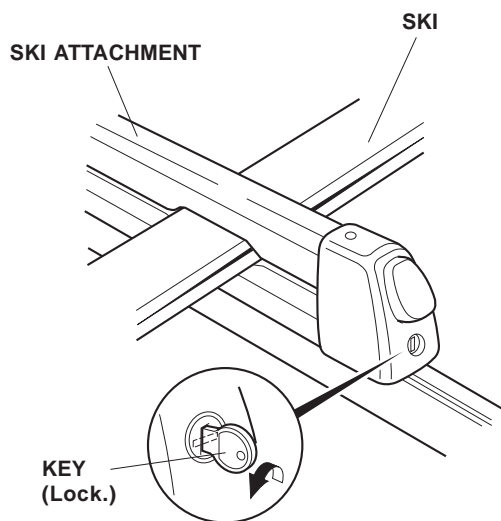

5. With the skis attached, rock the attachment in all directions to make sure it is installed securely. Adjust as necessary.

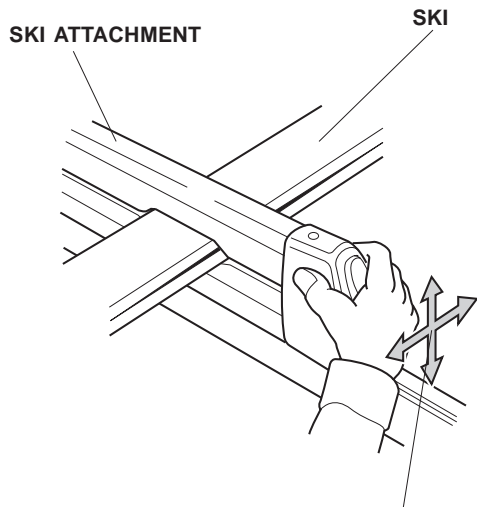

Rock the ski attachment in all directions to make sure it is installed securely.