



Applies To: **2003–05 Element – ALL**  
**2006 Element 2WD** – From VIN 5J6YH1...6L000001 thru 5J6YH1...6L007635  
**2006 Element 4WD** – From VIN 5J6YH2...6L000001 thru 5J6YH2...6L012681

**November 3, 2006**

## Element: Driver's Seat Rocks

(Supersedes 03-032, dated June 25, 2004, to update the information marked by the black bars)

### SYMPTOM

The driver's seat rocks back and forth during normal driving.

### PROBABLE CAUSE

There are worn bushings in the height adjustment mechanism.

### CORRECTIVE ACTION

Install new seat bushings, nuts, and spacers.

Use brake cleaner to remove grease from any threads before installing the nut.

### PARTS INFORMATION

Nut With Washer, (six required):  
P/N 90321-SCV-A11, H/C 7952138

Seat Link Bushing (six required):  
P/N 90502-S3N-013, H/C 6690440

Spacer (three required):  
P/N 90503-S3N-003, H/C 6852578

### REQUIRED MATERIALS

Brake Cleaner: P/N 08732-0010, H/C 6985634  
(One can repairs four vehicles.)

### REPAIR PROCEDURE

1. Make sure you have the anti-theft code for the radio, then write down the frequencies for the preset buttons.
2. Disconnect the negative cable from the battery, and wait at least 3 minutes before beginning work.
3. Remove the driver's seat from the vehicle.
  - Refer to page 20-86 of the *2003–06 Element Service Manual*, or
  - Online, enter keyword **SEAT**, and select **Front Seat Removal/Installation** from the list.
4. Place the seat on a workbench covered with shop towels.
5. Pull off the recline handle.

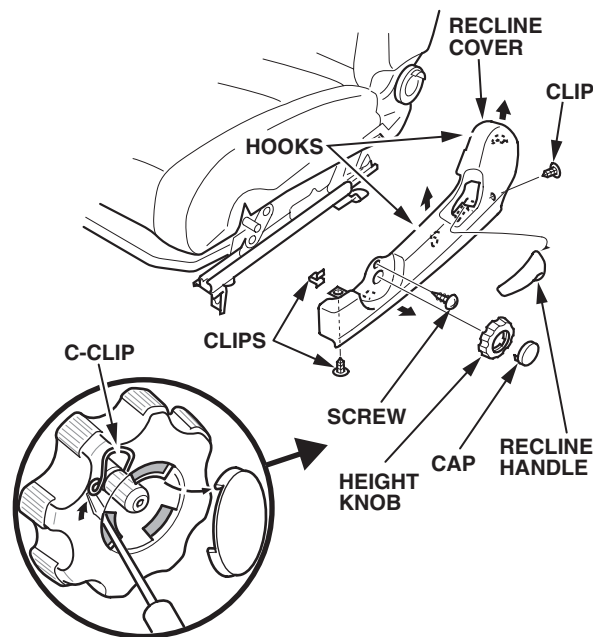

6. Pry the center cap from the height knob with a flat-tip screwdriver. Remove the C-clip, and pull off the knob.
7. Remove the recline cover (one screw, three clips, and two hooks).

8. Remove and discard the three nuts. Remove and retain the washers from the outboard front link and from the seat track. Remove and discard the three bushings.

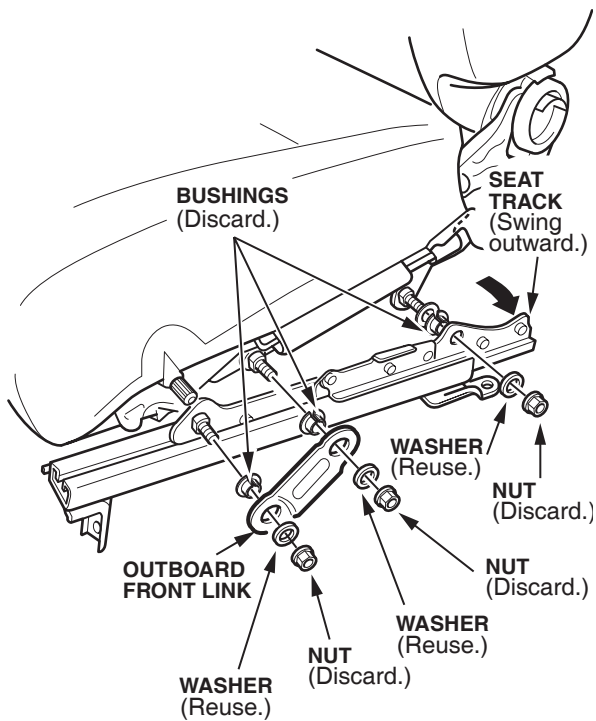

9. Install the three new bushings and the outboard front link.

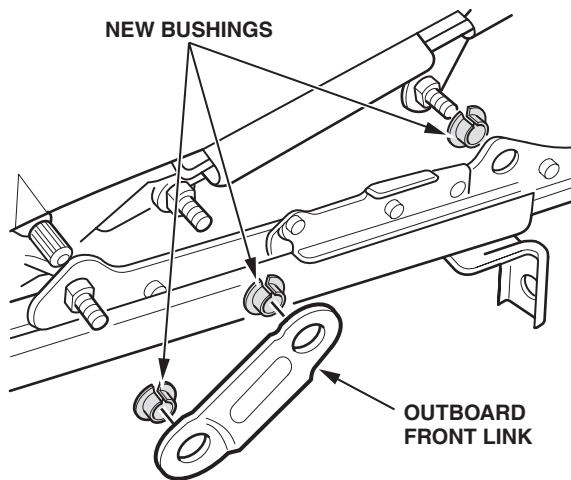

10. Use brake cleaner to remove grease from any threads before installing the nuts. Install the original washers and new nuts. Torque the nuts to **22 N·m (16 lb-ft)**.

11. Remove the center cover (three clips and two hooks) from the inboard seat track. Then remove the seat belt buckle (center anchor bolt, collar, spring washer, and toothed lock washer).

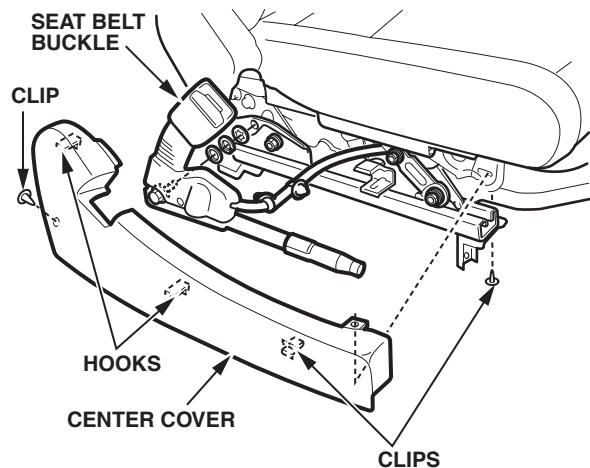

12. Remove and discard the three nuts. Remove and retain the washers from the inboard front link and the seat track. Remove and discard the three bushings. Remove and discard the spacers between the seat and the seat track.

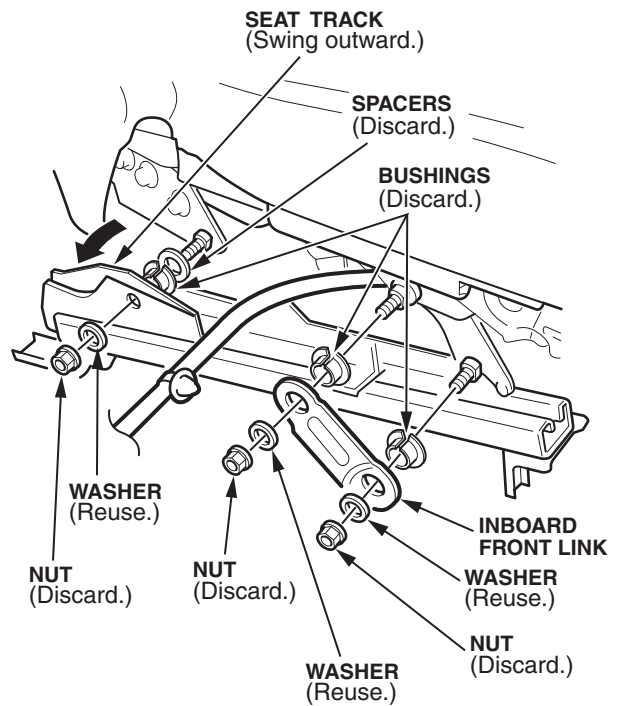

13. Add the three new spacers to the rear mounting stud.

**NEW SPACERS**

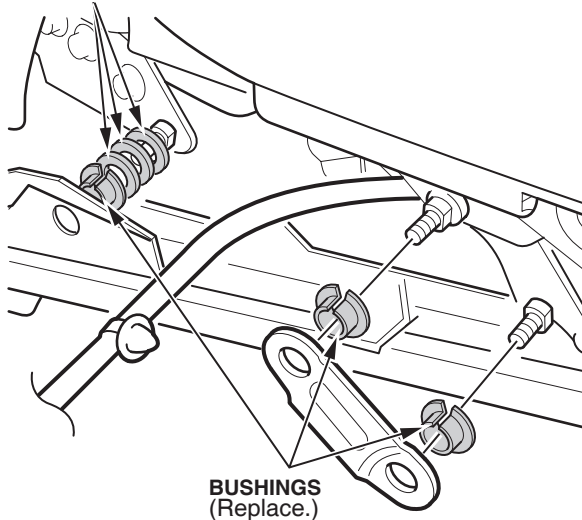

14. Install the three new bushings and the inboard front link.
15. Use brake cleaner to remove grease from any threads before installing nuts.  
Install the original washers and new nuts. Torque the nuts to **22 N·m (16 lb-ft)**.
16. Reinstall the seat belt buckle. Torque the center anchor bolt to **32 N·m (24 lb-ft)**.
17. Reinstall the center cover and the recline cover.
18. Reinstall the height knob and the recline handle.
19. Reinstall the driver's seat:
- Torque the mounting bolts to **34 N·m (25 lb-ft)**.
  - Make sure each connector is properly plugged in.
20. Confirm that the problem is resolved. If the driver's seat still rocks, look for other causes.
21. Reconnect the negative cable to the battery.
22. Turn the ignition switch to ON (II), and check the SRS indicator. If the indicator comes on for 6 seconds and then turns off, the SRS is OK. If the indicator stays on, check for codes, and do normal troubleshooting.

23. Enter the anti-theft code for the radio and your customer's radio station presets. Set the clock.

24. Initialize the driver's window auto-up feature:

- Make sure the driver's window is fully closed.
- Push down and hold the window switch until the window goes all the way down.
- Pull back and hold the window switch until the window goes all the way up, then hold the switch for at least 2 more seconds.

25. Do the ECM/PCM idle learn procedure:

- Make sure all electrical items (A/C, audio unit, defogger, lights, etc.) are off.
- Start the engine, and let it warm up to its normal operating temperature (the cooling fans cycle twice).
- Let the engine idle (throttle fully closed with all electrical items off) for 10 minutes.