



INSTALLATION INSTRUCTIONS

Accessory
TRAILER HITCH KIT

Application
ODYSSEY

Publications No.
All 24142
Issue Date
AUG 2002

PARTS LIST

Trailer Hitch:
P/N 08L92-S0X-100

Trailer hitch

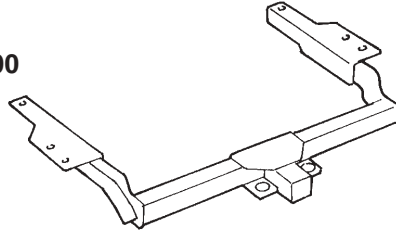

Ball mount



Hitch pin



Hitch pin clip



6 Bolts, 12 x 40 mm



6 Plain washers, 12 mm



6 Lock washers, 12 mm



Trailer hitch harness

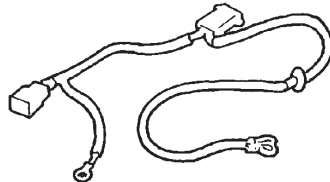

Plate R

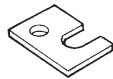
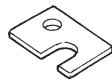

Plate L



Receiver cover



2 Small wire ties
(1 not used)

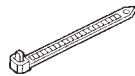

7 Cushion tapes



Washer-bolt, 6 x 12 mm



Flange nut, 6 mm



Heavy-Duty P/S Cooler Kit
P/N 53765-S0X-305

Heavy-duty P/S Cooler

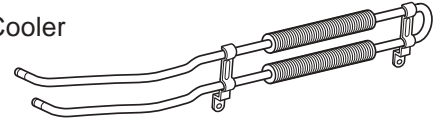

ATF Cooler Kit
P/N 06255-P7T-305

ATF Cooler

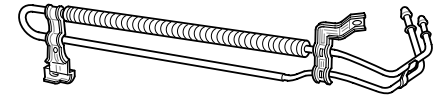

Rubber hose

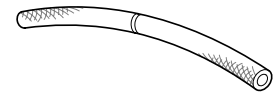

Washer-bolt, 6 x 15 mm



2 Bolts, 6 x 10 mm (not used)



Bracket (not used)



3 Hose clamps



Hose spacer



Mirror "hang tag"



TOOLS AND SUPPLIES REQUIRED

Phillips screwdriver
Flat-tip screwdriver
Ratchet
5 mm, 6 mm, 10 mm, 12 mm, and 19 mm Sockets
Pliers
Utility knife
Clip remover
Sandpaper
Torque wrench
Drill
17 mm Hole saw
Gloves
Blanket

INSTALLATION

Customer Information: The information in this installation instruction is intended for use only by skilled technicians who have the proper tools, equipment, and training to correctly and safely add equipment to your vehicle. These procedures should not be attempted by “do-it-yourselfers.”

NOTE: Let the P/S fluid, the ATF, and the surrounding parts cool down before you install the coolers.

Installing the Trailer Hitch

1. Remove the rear taillights:
 - Using a flat-tip screwdriver, pry open the two bolt covers.
 - Remove the two 5 mm washer-bolts, and pull the taillight out toward you to release the clip.
 - Unplug the 5-pin connector, and remove the taillight.
 - Repeat on the other side.

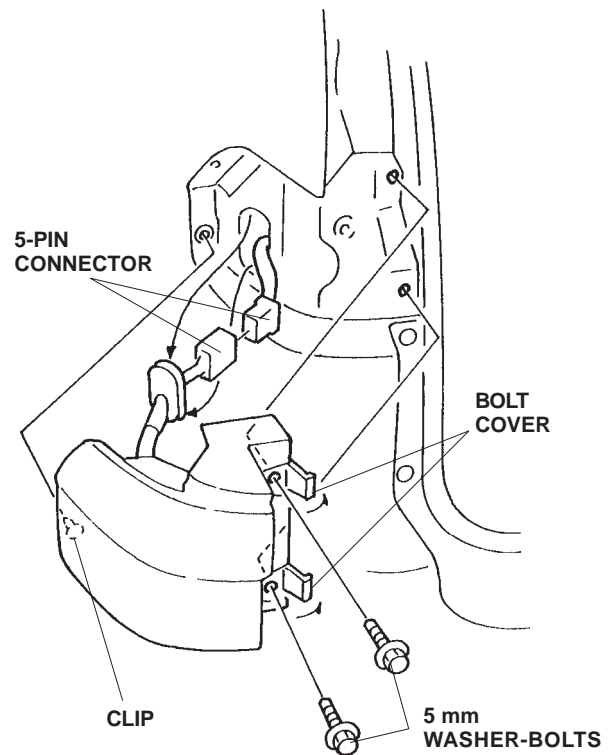

2. Remove the rear bumper:

- Remove the eight clips along the top and bottom of the bumper.
- Remove the four screws (two on each side) from the top at the taillight area and from the bottom near the rear wheel.
- Using a clip remover, pry out and remove one clip from each fenderwell.
- Using a flat-tip screwdriver, pry out and remove the bumper bolt covers, then remove the four bumper bolts.
- With the help of an assistant, release the bumper from the fenderwell, and slide the bumper away from the vehicle.
- Set the bumper on a blanket.

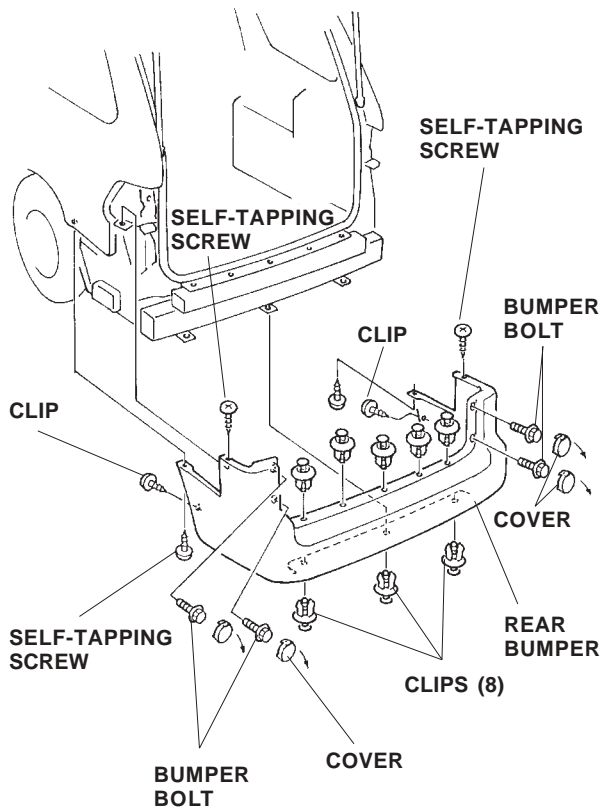

3. On the inside of the rear bumper, locate the scribed line on each side of the bumper. Using a utility knife, cut out the marked areas.

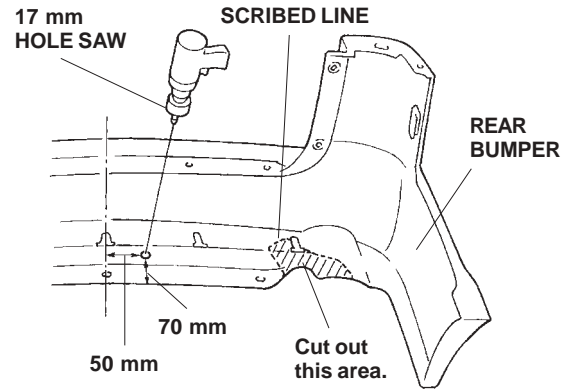

4. In the center of the bumper, measure and mark the bumper in the area shown.
5. While wearing eye protection, use a hole saw to drill a 17 mm hole through the bumper.
6. Install the trailer hitch to the rear frame, using the six 12 x 40 mm bolts, lock washers, and plain washers. Place plate L and plate R between the frame and the hitch on the left and right sides at the rear bolts.

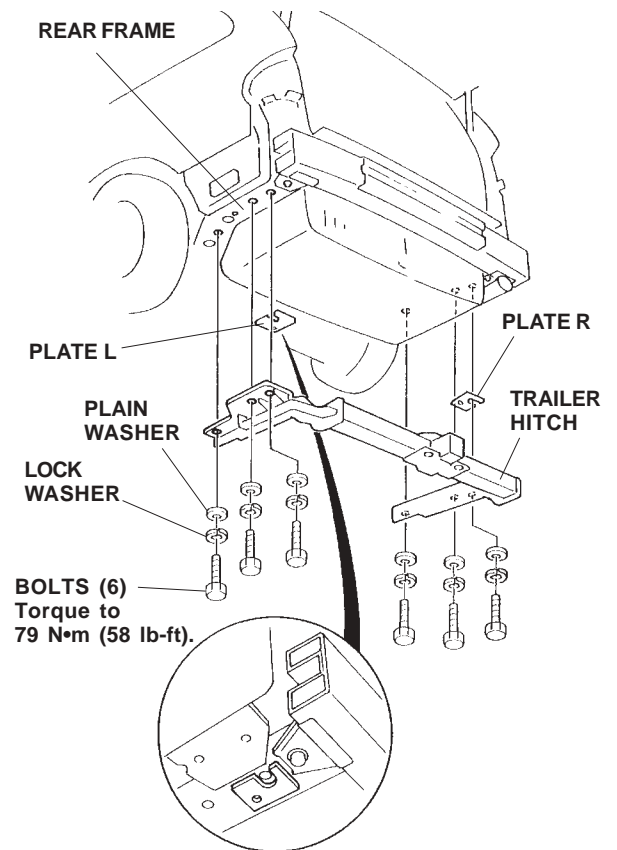

7. Torque the trailer hitch bolts to 79 N•m (58 lb-ft).

8. Remove the tailgate weatherstrip and rear panel (ten clips and two self-tapping screws).

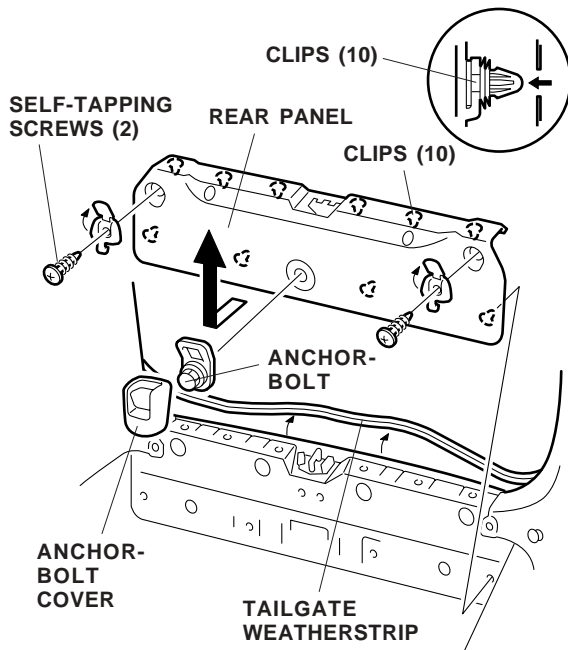

9. Remove the jack cover and the jack (one knob and four retaining tabs).

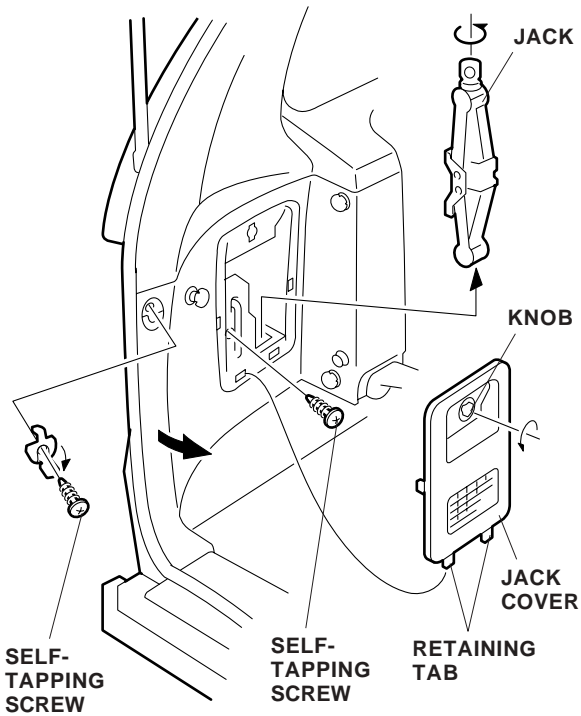

10. Remove the two self-tapping screws.

11. Pry out on the two clips and the three retaining tabs, and pull out the left side panel.

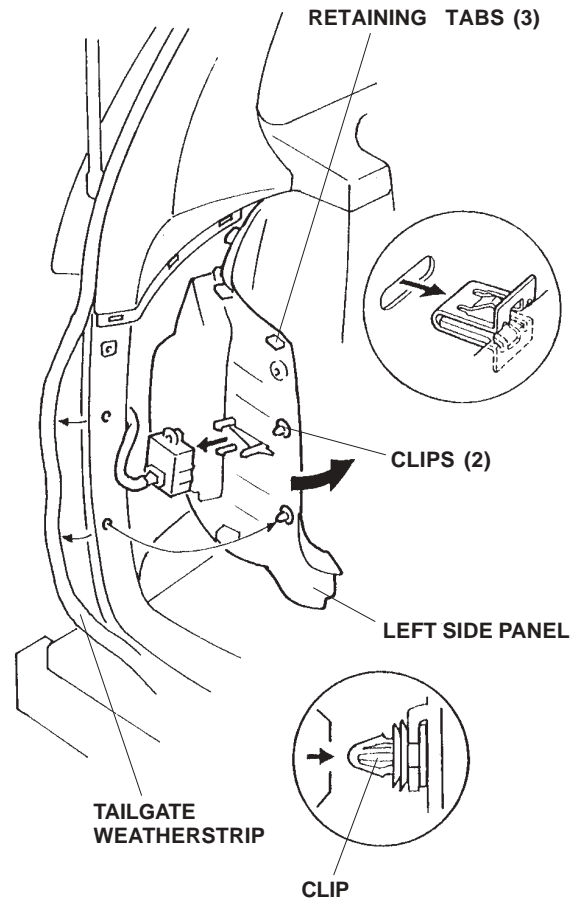

- Remove the wire tie with clip, which secures the vehicle harness, from the body hole; then secure the harness to the body with one cushion tape.

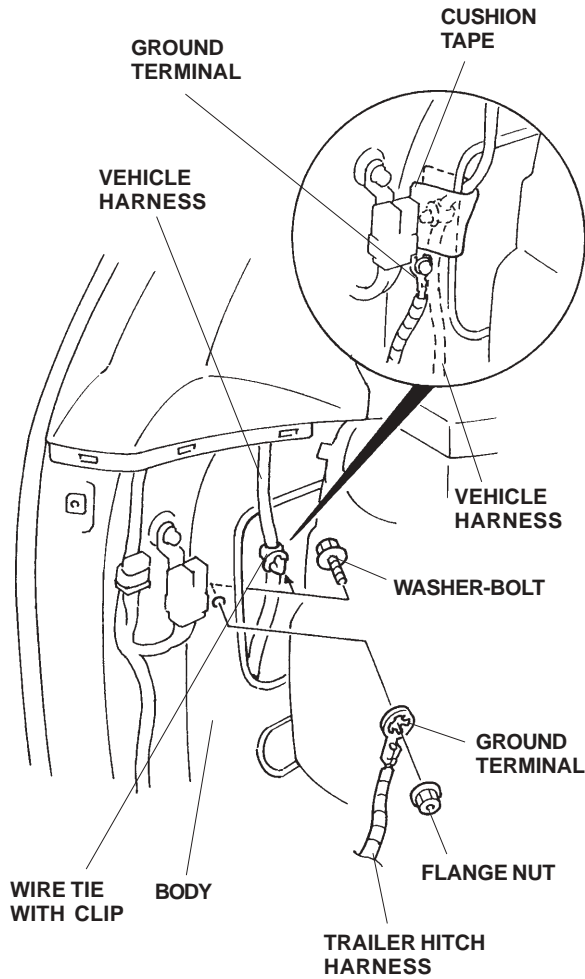

- Using sandpaper, remove the paint from around the body hole where the clip was removed.
- Attach the ground terminal of the trailer hitch harness to the body hole with the washer-bolt, toothed washer, and flange nut from the kit. Tighten the bolt securely.

- Locate the 6-pin connector blue-taped to the vehicle harness, and remove the blue tape to free the connector. Plug the 6-pin connector of the trailer hitch harness into the 6-pin connector you just freed.

Without a Backup Sensor:

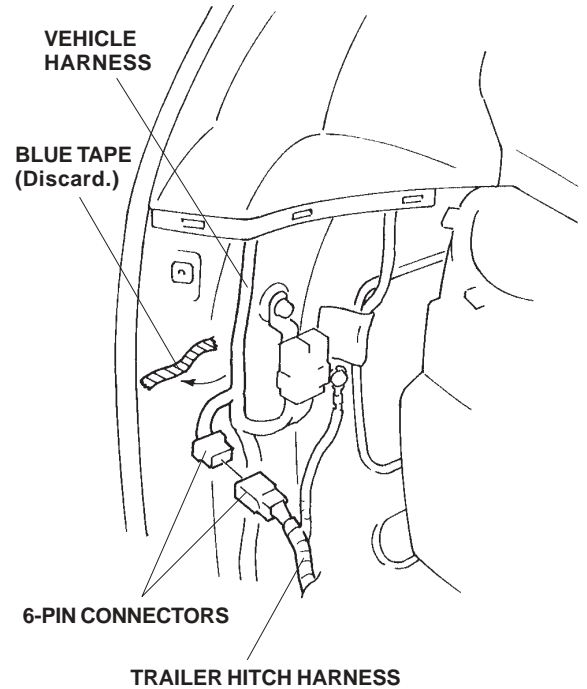

With Backup Sensor:

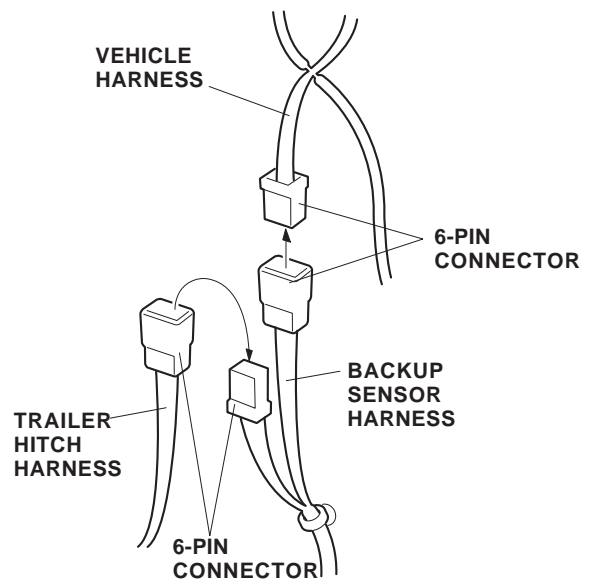

16. Remove the adhesive backing from the trailer hitch harness converter, and attach it to the body in the area shown.

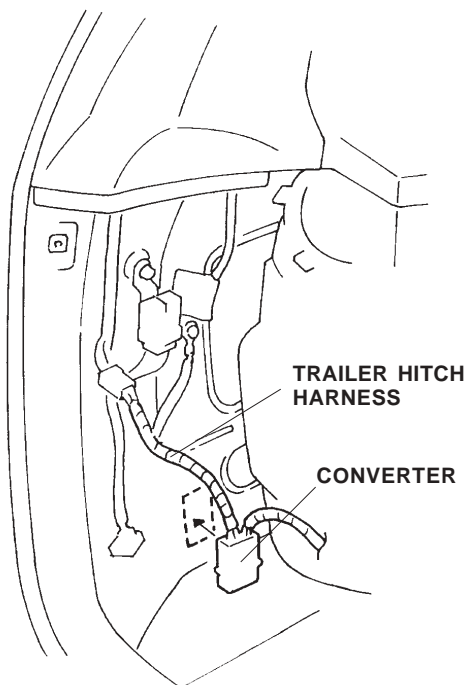

17. Secure the trailer hitch harness to the vehicle harness with one small wire tie; then secure the harness to the body with one cushion tape in the area shown.

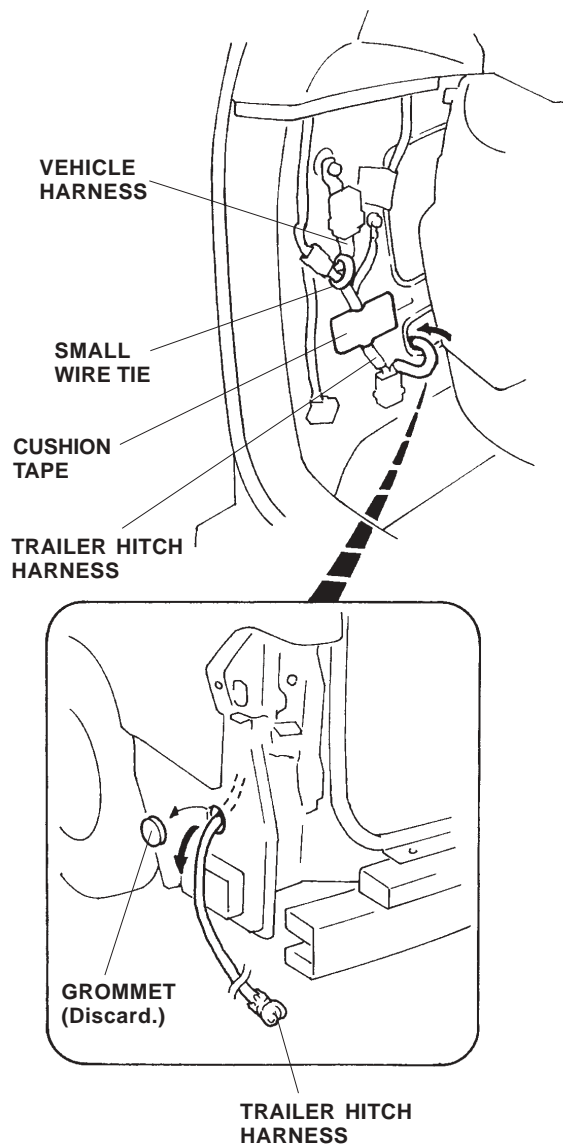

18. Remove and discard the grommet from the rear of the outside panel, and route the trailer harness out through the grommet hole.

19. Seat the grommet on the trailer hitch harness into the body hole where the grommet was removed.

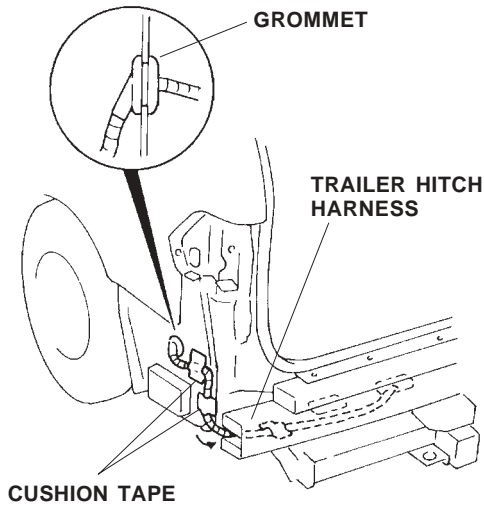

20. Secure the trailer hitch harness with two cushion tapes in the areas shown; then route the harness through the center of the bumper frame.
21. Continue routing the trailer hitch harness through the center bumper frame and out through the hole in the back. Secure the trailer hitch harness to the center bumper frame with two cushion tapes.

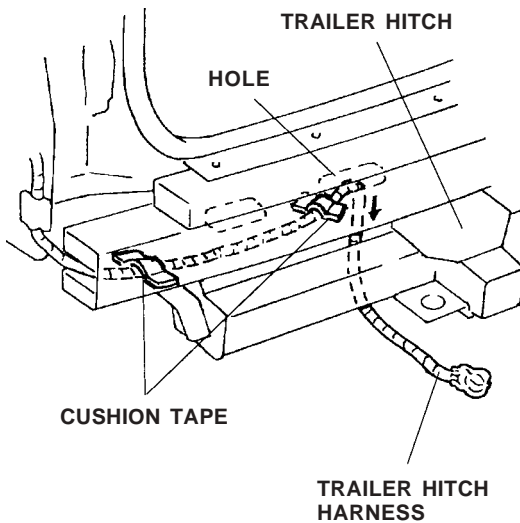

22. Place a shop towel over the trailer hitch. Route the trailer hitch harness through the hole in the bumper you drilled in step 5; then reinstall the rear bumper.

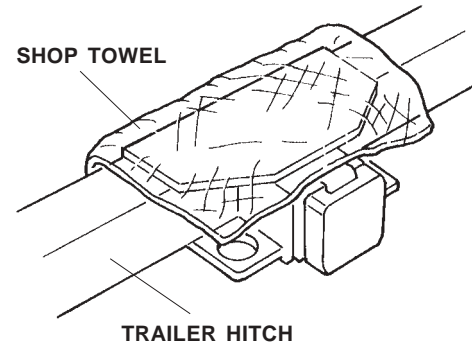

23. Secure the trailer harness to the back of the trailer hitch with one cushion tape.

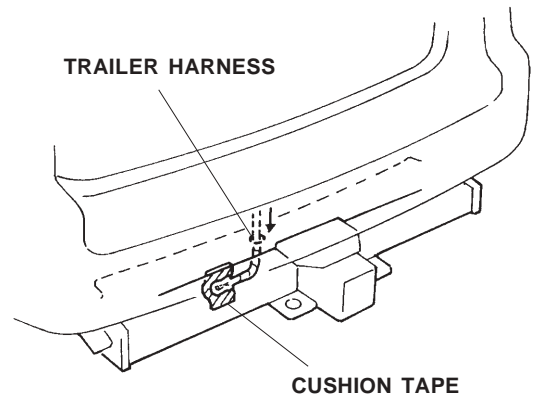

24. Install the receiver cover on the trailer hitch, then slide the ball mount into the trailer hitch, and secure the ball mount with the hitch pin and the hitch pin clip.

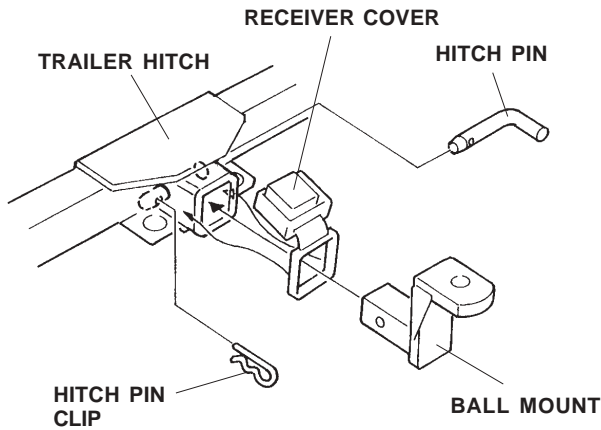

25. Reinstall the rear taillights, and reinstall all of the interior panels.

Installing the P/S Cooler

26. Remove the front bulkhead cover (11 clips).

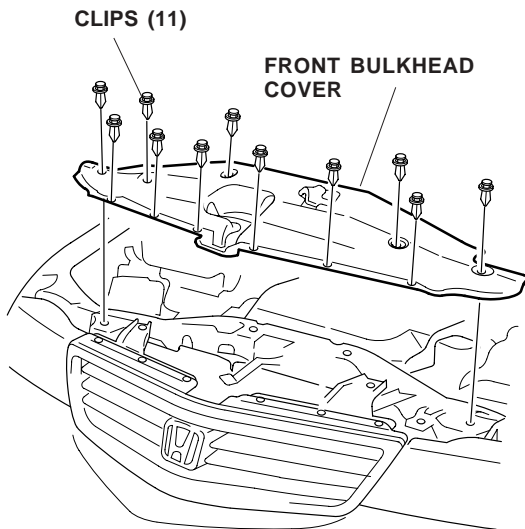

27. Remove the front bumper:

- Remove the four clips and two bolts along the bottom of the bumper.
- Remove one screw from the inside of each fenderwell.
- Lift the bumper off of the hooks, and set the bumper on a blanket while you install the P/S and ATF coolers.

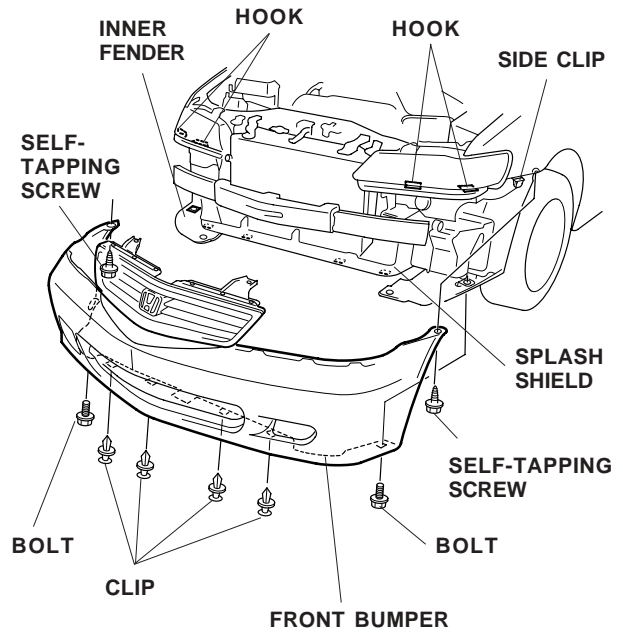

28. With a drain pan under the vehicle, remove the two bolts and two hose clamps that secure the existing P/S cooler. Disconnect the P/S fluid lines, and remove the power steering cooler. Set the P/S cooler aside; it will not be reused.

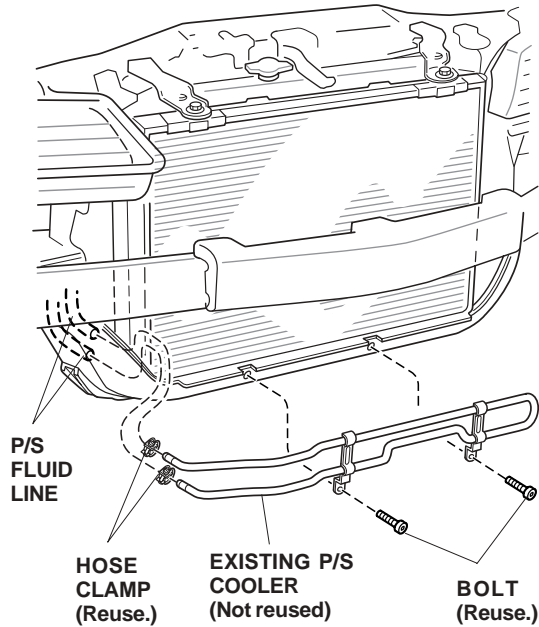

29. Place the heavy-duty P/S cooler on the radiator bulkhead, attach the P/S lines with the hose clamps, and reinstall the two bolts removed in step 28. Tighten the hose clamps and the center bolt, then remove the outboard bolt.

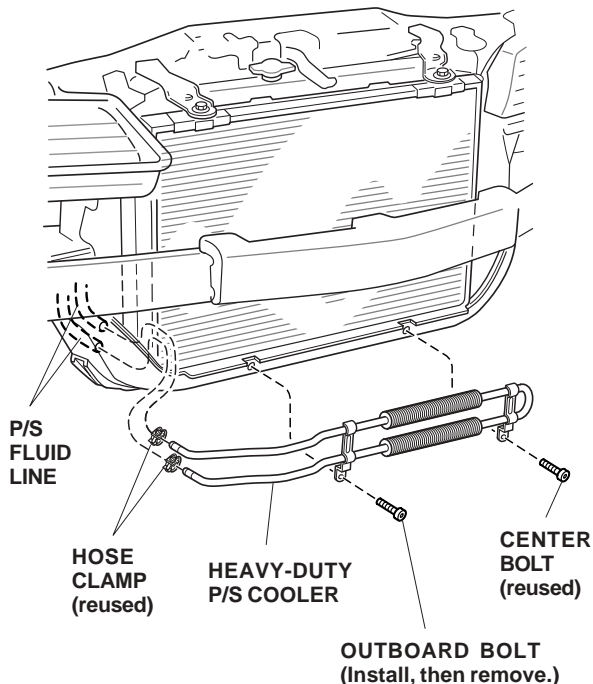

Installing the ATF Cooler

30. Position the ATF cooler lower bracket over the P/S cooler bracket, and reinstall the outboard bolt (removed in step 29) through the ATF cooler bracket and the P/S cooler bracket. Install the 6 x 15 mm washer-bolt (supplied) through the upper bracket of the ATF cooler bracket and into the threaded hole in the radiator bulkhead. Tighten both bolts securely.

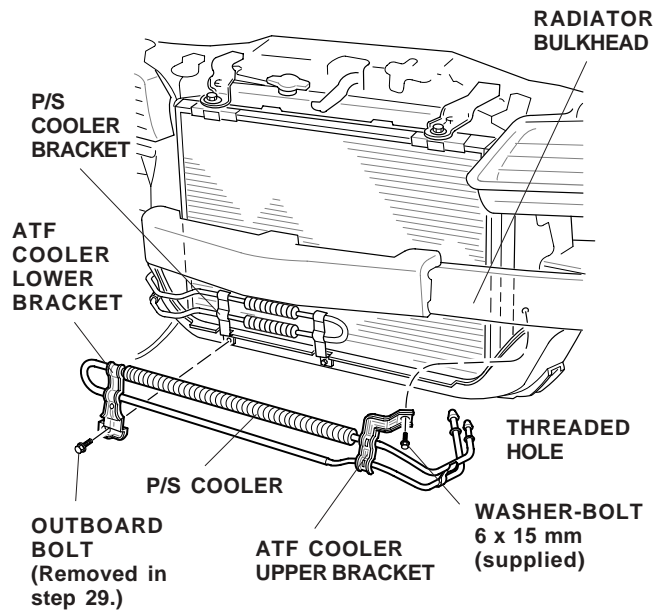

- Remove the ATF return line from the radiator return pipe, and attach it to the lower ATF cooler pipe using one new hose clamp from the kit.

FRONT VIEW

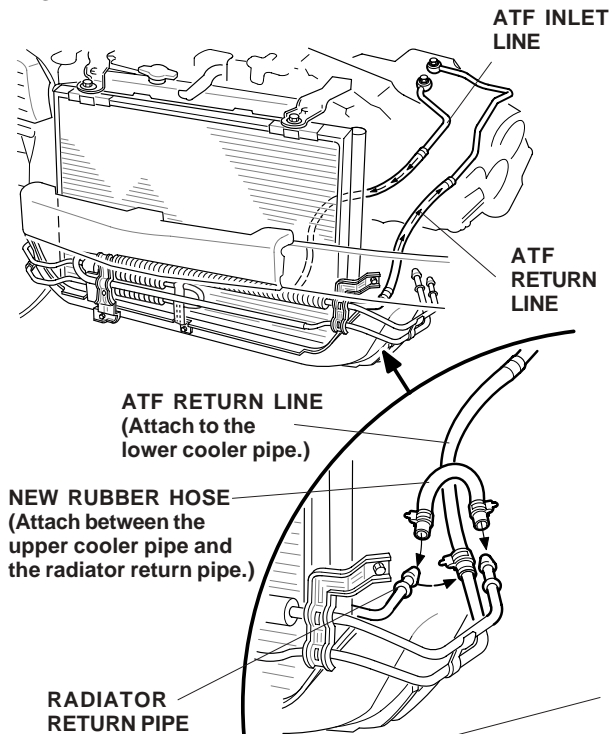

SIDE VIEW

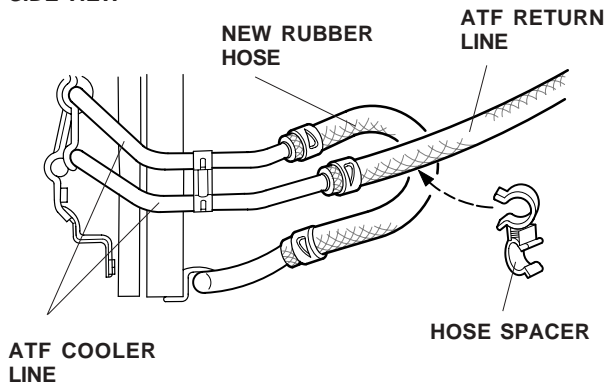

- Attach one end of the new rubber hose (supplied) to the upper pipe on the ATF cooler, and attach the other end to the radiator return pipe using the remaining two new hose clamps.
- Separate the new hose and the ATF return line by installing the hose spacer (supplied) between the two hoses at the area shown.

- Reinstall the front bumper and the front bulkhead cover.
- Start the vehicle and check for leaks; repair as necessary.
- Check the ATF, and the P/S fluid levels and adjust them as necessary.
- Attach the hang tag around the rear view mirror.