



INSTALLATION INSTRUCTIONS

Accessory

CD PLAYER
P/N 08A06-381-210

Application

ODYSSEY (LX)

Publications No.

All 24117

Issue Date

AUG 2002

PARTS LIST

CD player

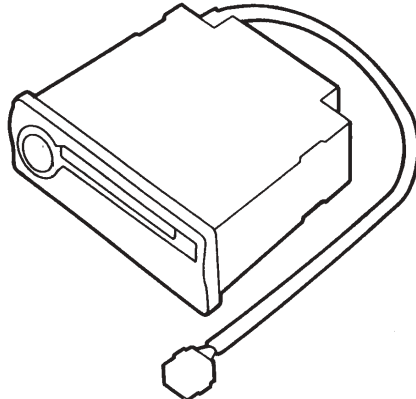

Owner's manual

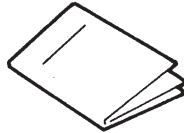

5 Washer-screws



Wire tie (not used)

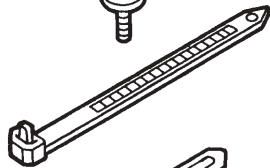

Harness clip

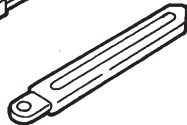

TOOLS REQUIRED

Phillips screwdriver

Small flat-tip screwdriver

INSTALLATION

1. Write down the customer's radio presets, then disconnect the negative cable from the battery.

2. Remove the console cover: [see pages 4 & 5 for updated panel removal instructions.](#)

- Move the gear selector lever to the 1 position.
- Using a small flat-tip screwdriver around a shop towel, gently pry out and remove the cover.
- Reach inside the cover hole, gently pull along the bottom to release the lower clips, and work toward the top to release all 10 clips.
- Pull out on the console panel, unplug the connectors and remove the panel.

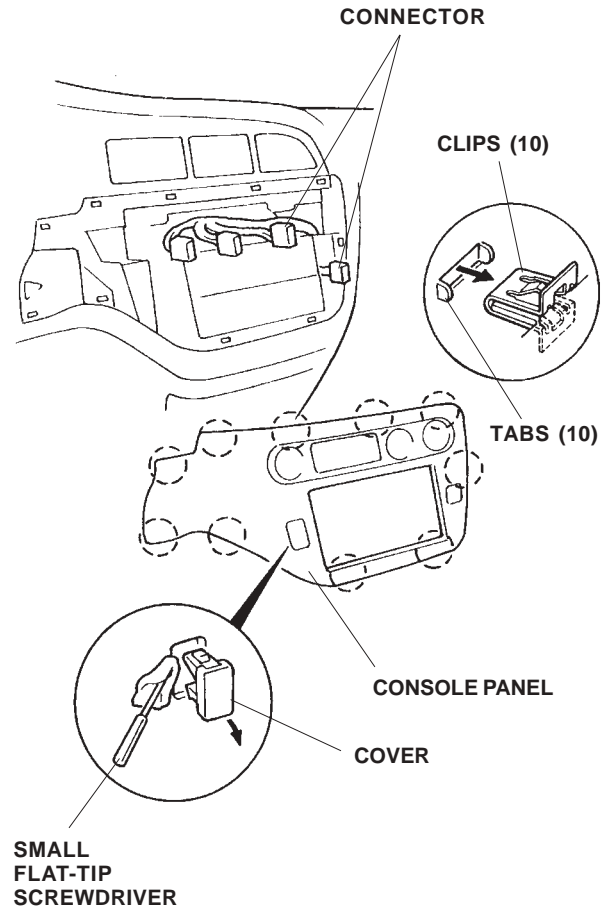

for 2003-2004 Models Please see pages 4 & 5 for updated panel removal instructions.

- Remove the radio (four bolts, and unplug the connector and antenna lead).

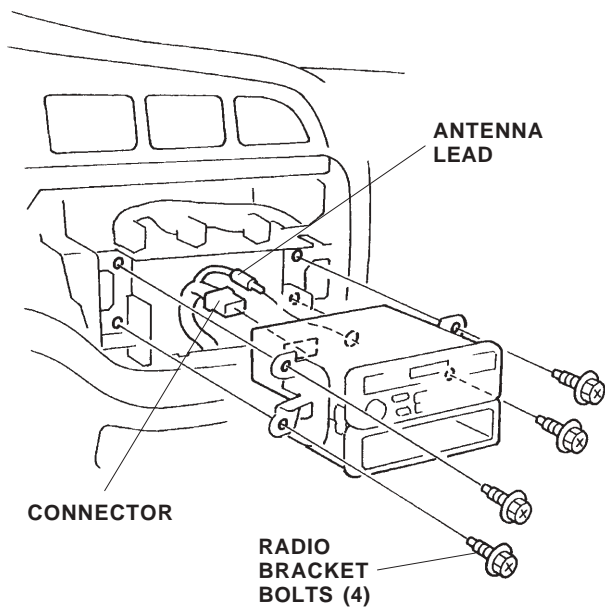

- Remove the left and right radio brackets (two washer-screws for each bracket).

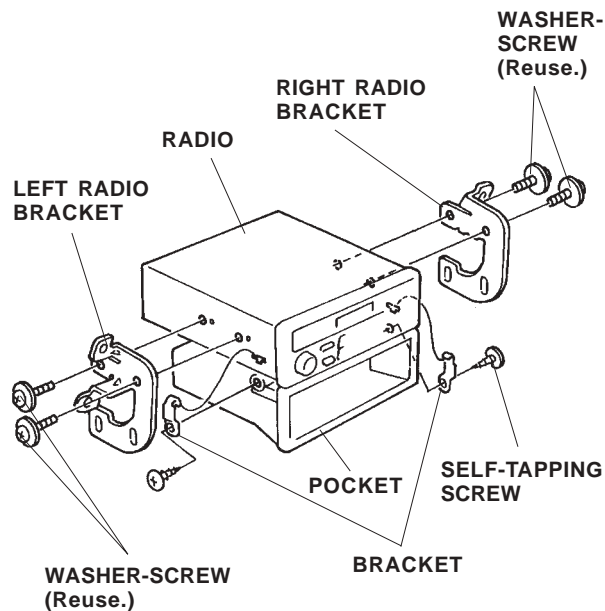

- Remove the pocket (two self-tapping screws), then separate the radio and pocket. Set the pocket aside, it will not be used.

- Position the CD player on the radio, and reinstall the left and right radio brackets and four washer-screws removed in step 4. Use four 5 x 8 mm washer-screws (supplied) to secure the CD player to the radio brackets.

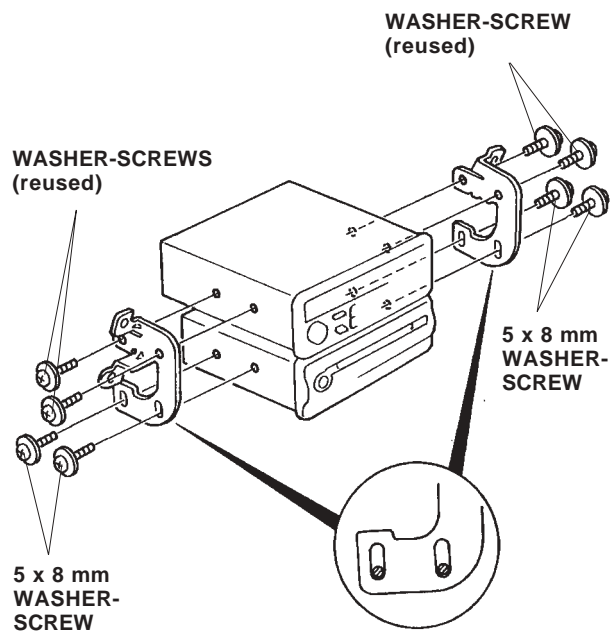

- Attach the harness clip to the back of the CD player with the remaining 5 x 8 mm washer-screw. Plug the BUS cable into the rear of the radio/cassette player; then fold the excess BUS cable several times, and secure it to the back of the CD player with the harness clip.

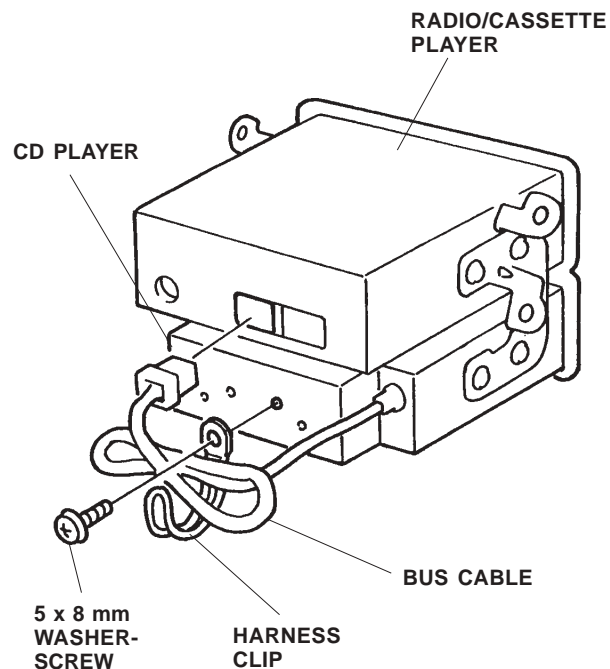

8. Plug the radio connector, and the antenna lead into the back of the radio/cassette player; then reinstall the radio in the dash.

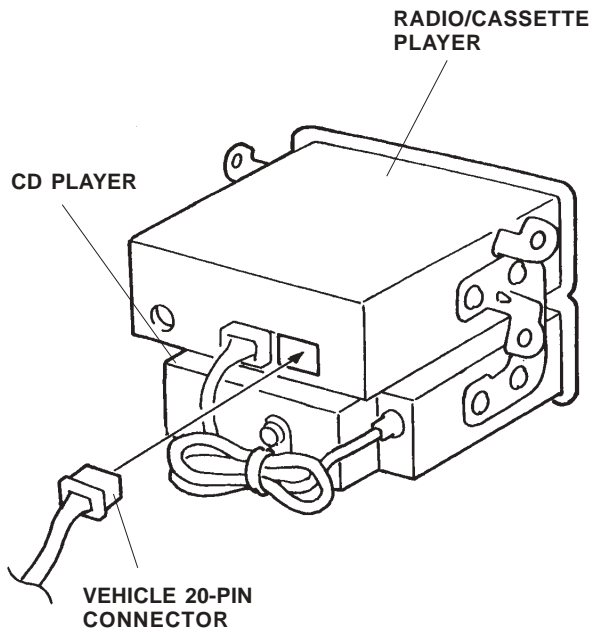

9. Reinstall the console panel; be careful not to damage the tabs.

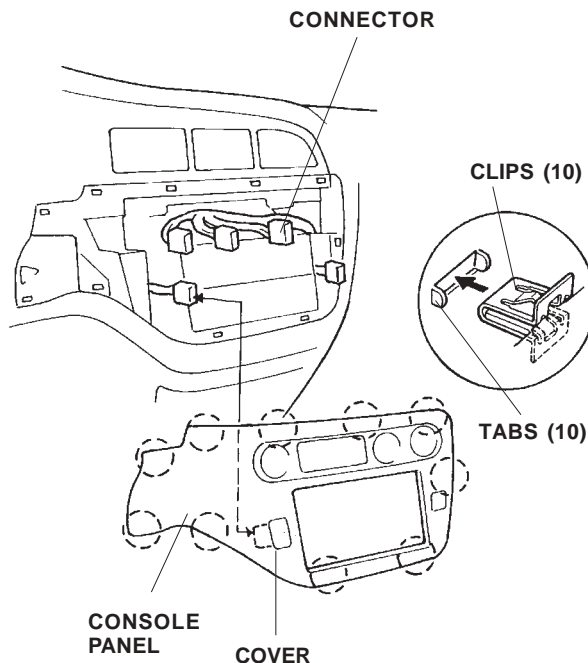

10. Reconnect the negative cable to the battery.
11. Check the operation of the CD player according to its Owner's Manual.
12. Enter the radio anti-theft code, and reset the customer's radio station presets.
13. Reset the clock.
14. Put the CD player Owner's Manual in the glove box.

NOTE: Whenever the battery is disconnected, the driver's window AUTO function is disabled.

15. Start the engine. Push down on the driver's window switch until the window is fully open.
16. Pull up on the driver's window switch to close the window completely, then hold the switch for a second or two more.
17. Test the driver's window AUTO function.
18. Do the PCM idle learn procedure.

– Make sure all electrical items are turned off.

– Start the engine. Hold the engine speed at 3,000 rpm with no load (in Park or Neutral) until the radiator fan comes on.

– Let the engine idle for about 5 minutes with the throttle fully closed and with all electrical items off.

NOTE: If the radiator fan comes on during this step, the time when it is operating must not be included in the 5 minutes.

2003 Odyssey Audio Panel Removal Updated Procedure



1. Insert a small screwdriver into left side of storage bin between it and the panel. Cover the screwdriver with either thin cloth or electrical tape to protect the panel



3. Repeat procedure on other side of storage bin.



2. Pry panel away from storage bin. The clip that holds the panel in place will make a popping sound when it releases.



4. Reach under panel and pull outwards to allow room to move up the side of the panel.



5. Slide one hand up the side of the panel, pulling to release the next clip.



8. With the panel loose remove the wiring connectors from the back of the panel



6. Repeat the procedure on the left side of the panel



7. With the gear selector in the #1 position get a firm grip on both sides of the panel and pull straight out.