

INSTALLATION INSTRUCTIONS

Accessory
FOG LIGHTS P/N08V31-S0X-102

Application
ODYSSEY

Publications No.
All 26009-27301
Issue Date
JUNE 2004

PARTS LIST

Right fog light

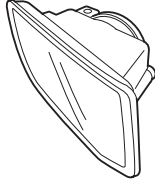

Left fog light



Right bracket

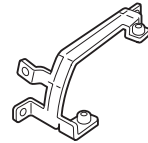

left bracket

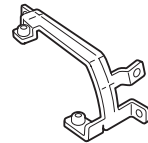

Harness A

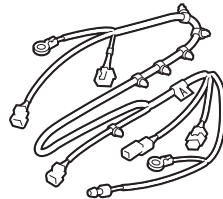

Harness B

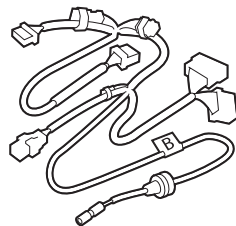

Switch

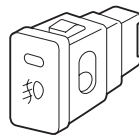

Fuse label (20A)

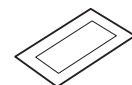

Fuse label (2A)

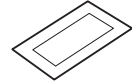

Relay A, 4-pin
(with rubber cover)

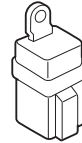

Relay B, 4-pin

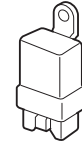

8 Washer-screws
(with small washer)



Battery terminal nut



Fusible link

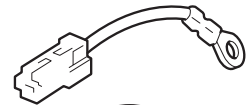

2 Washer-screws
(with big washer)



Ground bolt

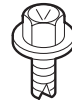

4 Spring nuts



19 Wire ties

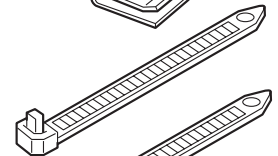

2 Wire ties with holder



Wire clip

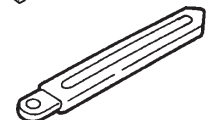

TOOL AND SUPPLIES REQUIRED

Phillips screwdriver
Stubby #2 Phillips screwdriver
10 mm Socket
Ratchet
Diagonal cutters
10 mm Combination wrench
Drill
6 mm Drill bit
Eye protection (face shield, safety goggles, etc.)
Hacksaw blade
File
Electrical tape
Flat-tip screwdriver
Felt-tip pen

Illustration of the Fog Lights Installed on the Vehicle

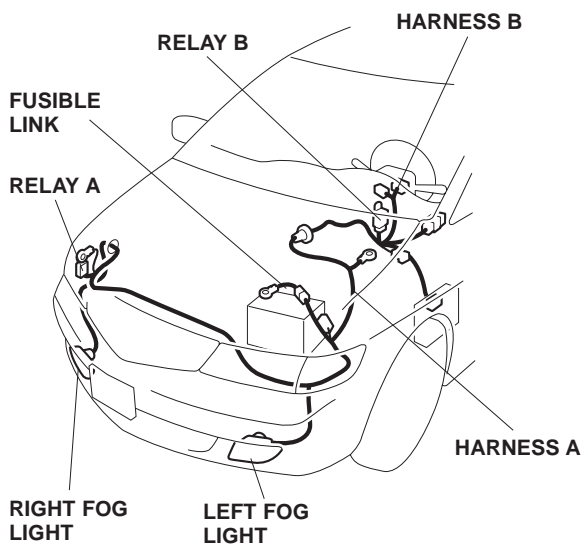

INSTALLATION

Customer Information: The information in this installation instruction is intended for use only by skilled technicians who have the proper tools, equipment, and training to correctly and safely add equipment to your vehicle. These procedures should not be attempted by “do-it-yourselfers.”

1. Make sure you have the anti-theft code for the radio, then write down the frequencies for the preset buttons.
2. Disconnect the negative cable from the battery.

Cutting The Front Bumper

3. Locate the two dimples on the left bumper grille. While wearing eye protection, drill a 6 mm hole through each dimple.
4. Measure and mark the horizontal louver of the left bumper grille, and cut out the marked area with a hacksaw blade. Be careful not to cut off the rib on the back of the front bumper. File the edges smooth and flat.

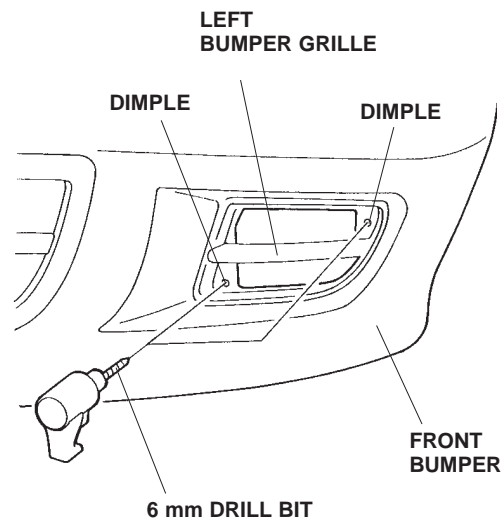

5. Locate the two dimples on the right bumper grille. While wearing eye protection, drill a 6 mm hole through each dimple.

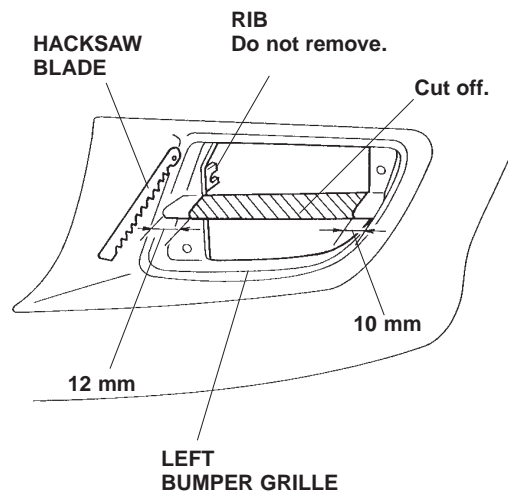

6. Measure and mark the horizontal louver of the right bumper grille.

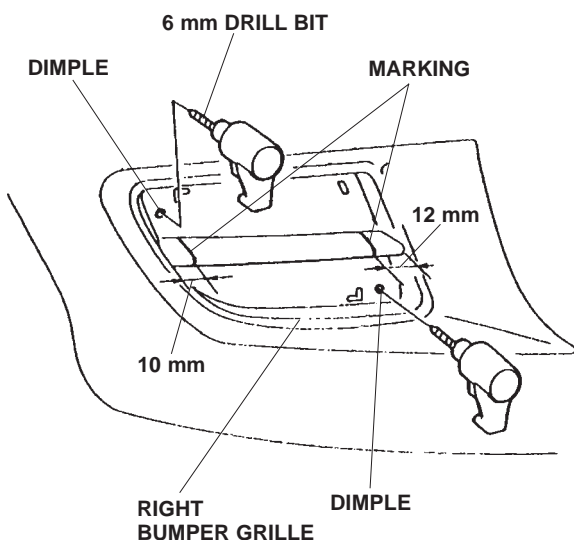

7. Locate the four cutouts in the right bumper grille. Draw lines from cutout to cutout.

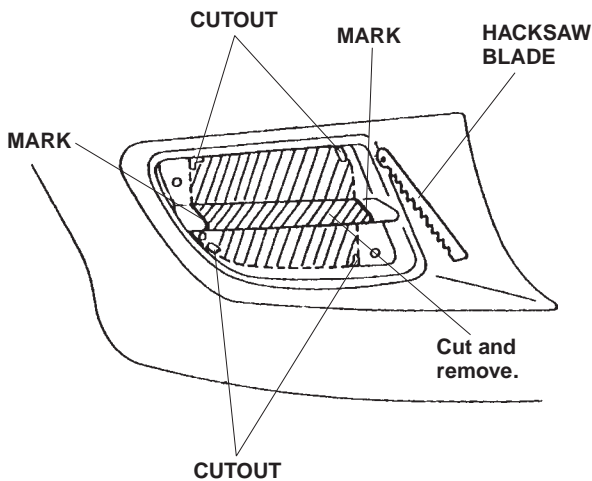

8. Using a hacksaw blade, cut out the marked area from the right bumper grille. Be careful not to cut off the rib on the back of the front bumper. File the edges smooth and flat.

Installing the Fog Light

9. Open the hood. Remove the upper cover (five clips).

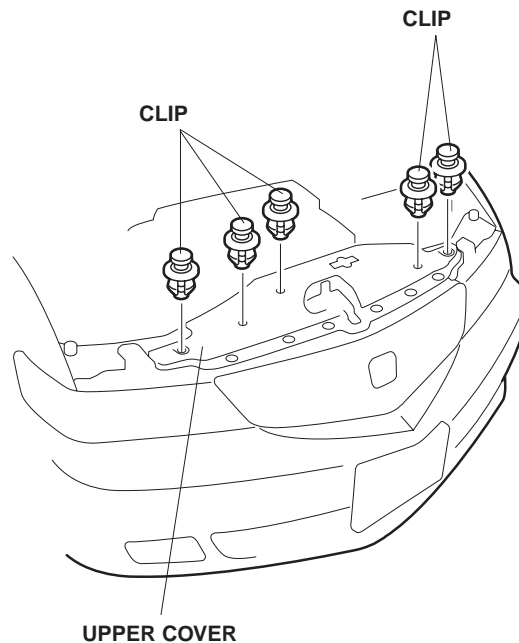

10. Remove the front bumper (two self-tapping screws, two bolts, and four clips).

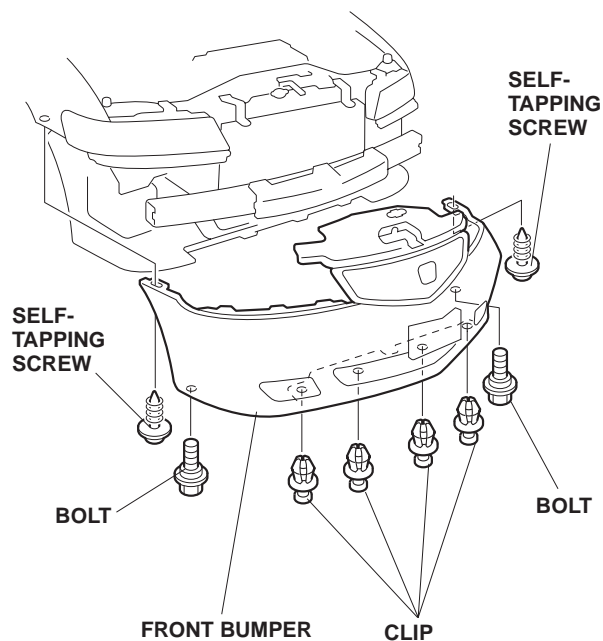

11. On the inside of the bumper, install two spring nuts on the left side.

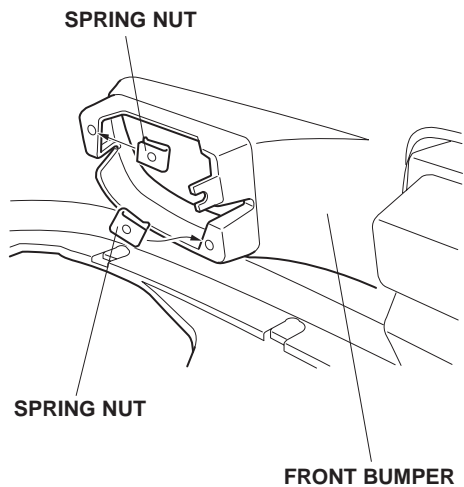

12. Position the left bracket on the front bumper grille opening, and install two washer-screws (with small washer) and one washer-screw (with big washer).

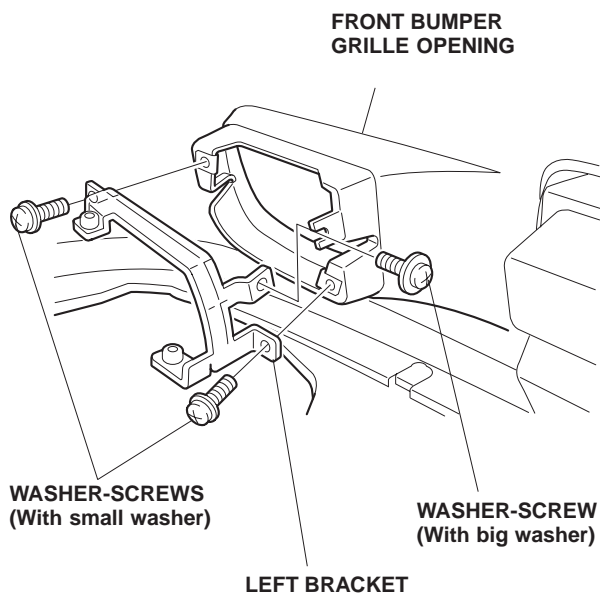

13. Insert the left fog light into the front grille opening, and install two washer-screws (with small washer).

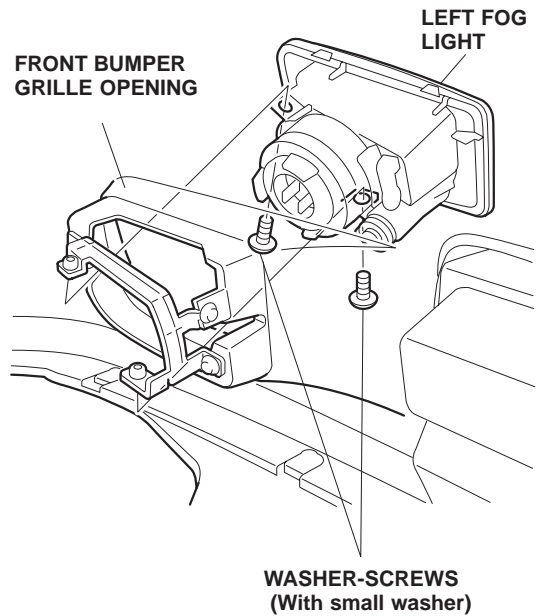

14. Repeat step 11 through 13 to install the right fog light.

Routing Harness A

15. Behind the left headlight, remove the cover (two clips and one retaining tab).

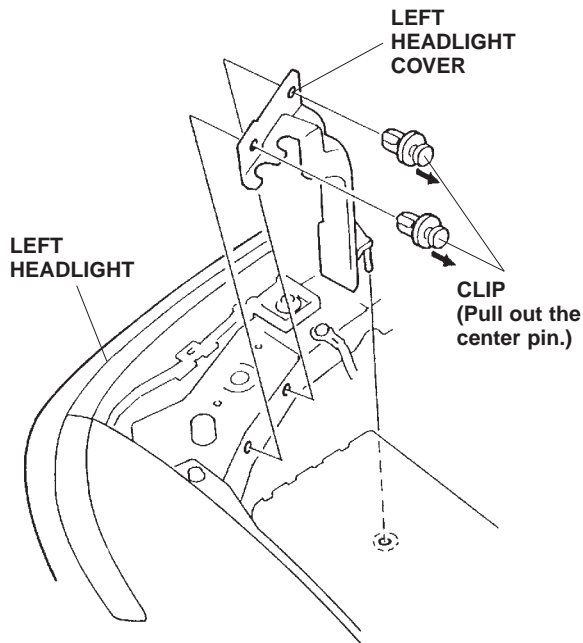

16. Attach one wire tie with holder to the fuse case of harness A, and secure the fuse case to harness A with the wire tie. Attach the other wire tie with holder to the 1-pin connector of harness A.

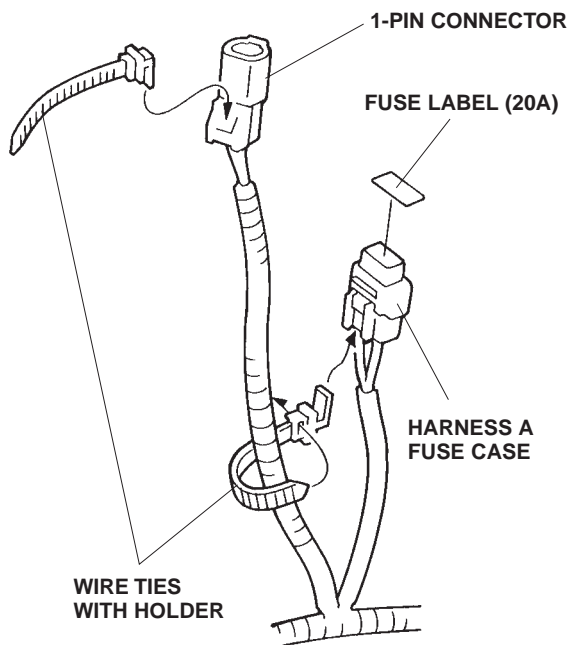

17. Attach the 20A fuse label to the fuse case.

18. Inside the engine compartment, route the terminal end of harness A alongside the vehicle harness on the left side of the vehicle between the battery and the air cleaner.

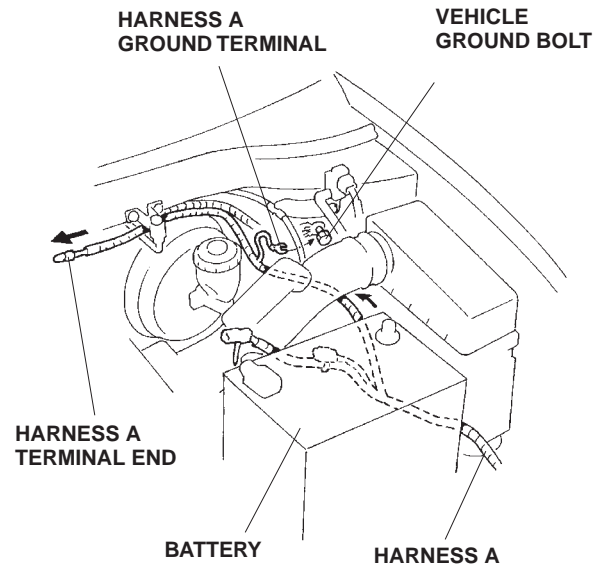

19. Loosen the ground bolt, and attach the harness A ground terminal with this ground bolt.
20. Attach the fusible link terminal to the positive battery terminal with the battery terminal nut. Plug the 1-pin connector of the fusible link into the 1-pin connector of harness A.

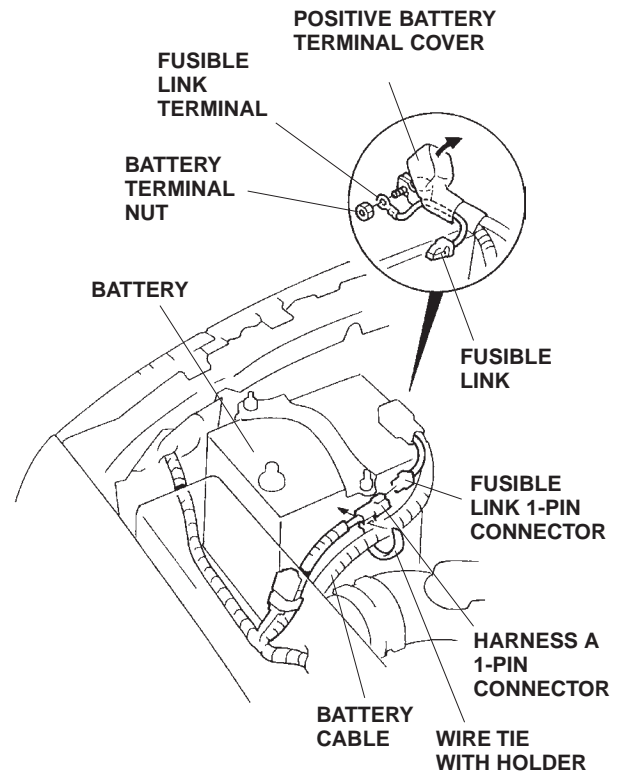

- Secure the 1-pin connector of harness A to the battery cable with the wire tie with holder installed in step 16.

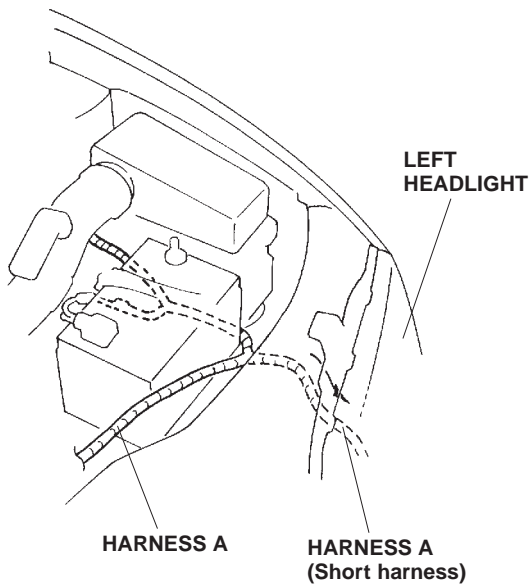

- Route the 2-pin connector of harness A (short harness) down behind the left headlight.
- Continue routing the 2-pin connector of harness A as shown, then push the clip on harness A into the hole in the left front bulkhead.

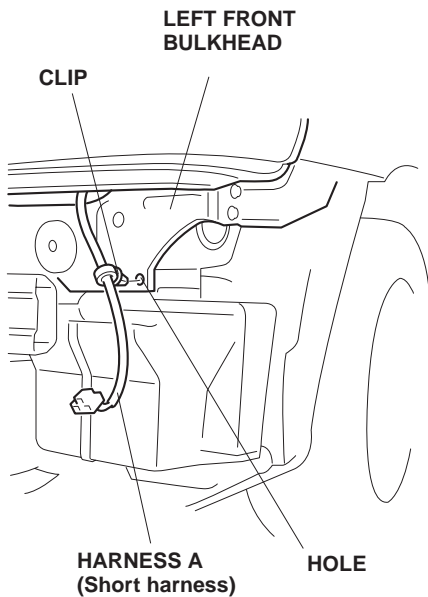

- Route the other 3-pin connector of harness A under the inside on the upper bulkhead, and secure it to the upper bulkhead by pushing the five clips into the holes in the bulkhead.

If equipped with an optional hood switch or optional harness, secure harness A to the optional harness with two wire ties inside the upper bulkhead, and cut off the clip from harness A.

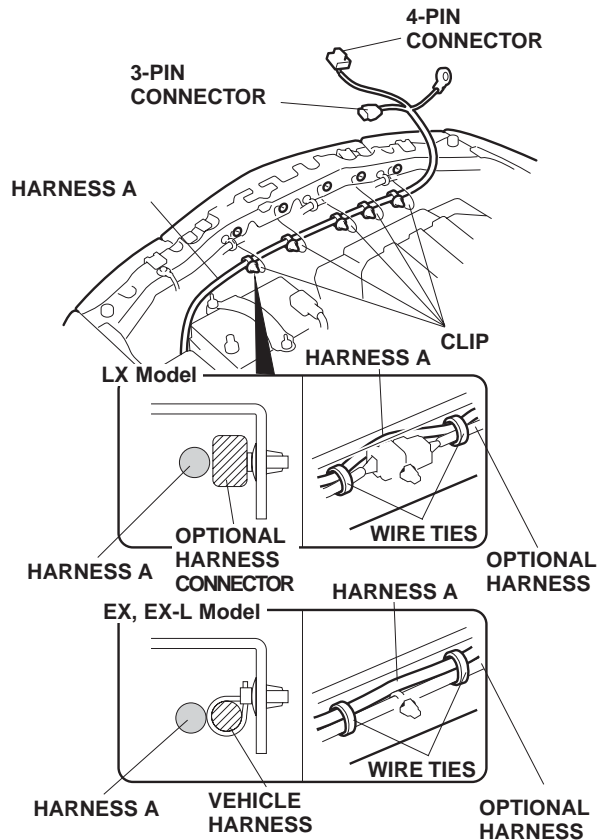

- Behind the right headlight, remove the radiator reservoir tank from the bracket by pulling it upward and moving it out of the way.

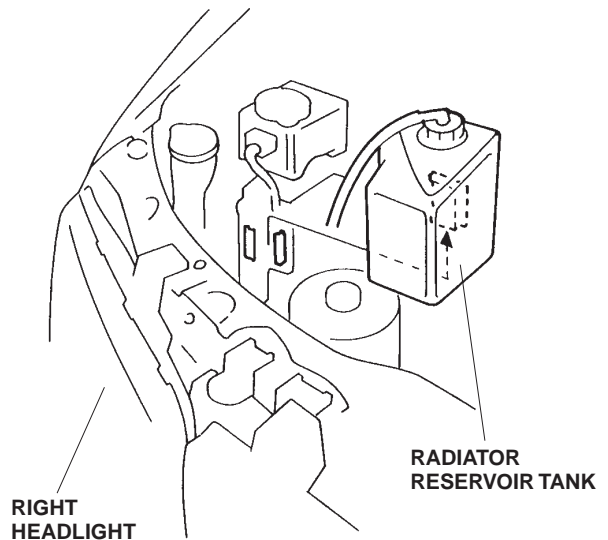

26. Plug the 4-pin connector of harness A into relay A, then attach relay A and the ground terminal to the inner panel behind the right headlight with the ground bolt supplied.

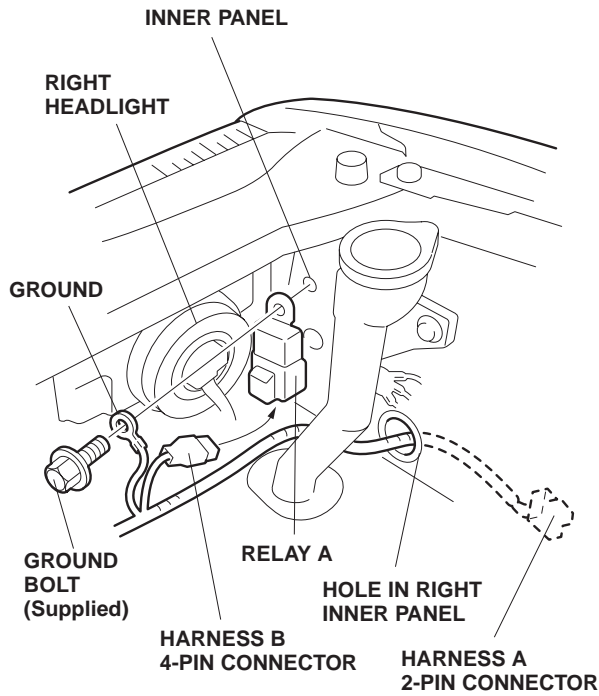

27. Route the 2-pin connector of harness A out through the hole in the right inner fender.

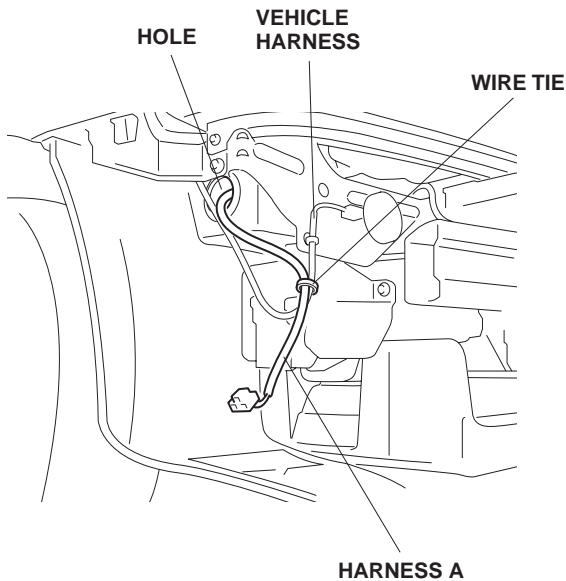

28. Secure harness A to the vehicle harness with one wire tie as shown.

29. Inside the engine compartment, secure harness A to the vehicle harness with four wire ties in the areas shown.

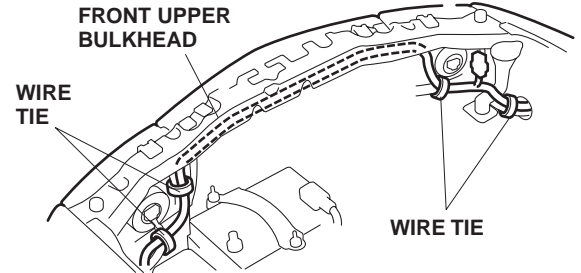

30. Continue to secure the rest of harness A to the vehicle harness with five wire ties in the areas shown.

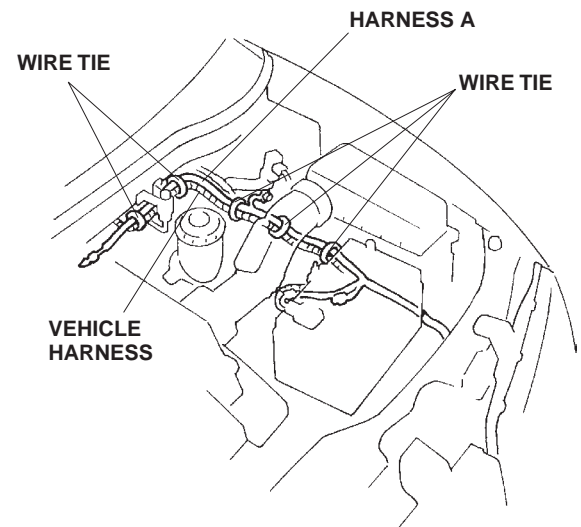

31. Plug the two harness A 3-pin connectors into the fog light connectors.

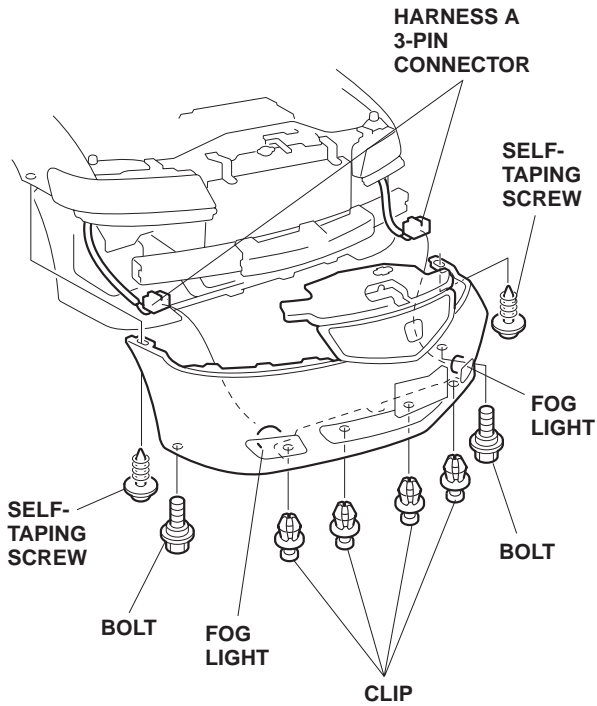

32. Reinstall the front bumper (two self-tapping screws, two bolts, and four clips).
33. Reinstall the upper cover.

Routing Harness B

34. Remove the fuel lid opener knob by sliding it forward.

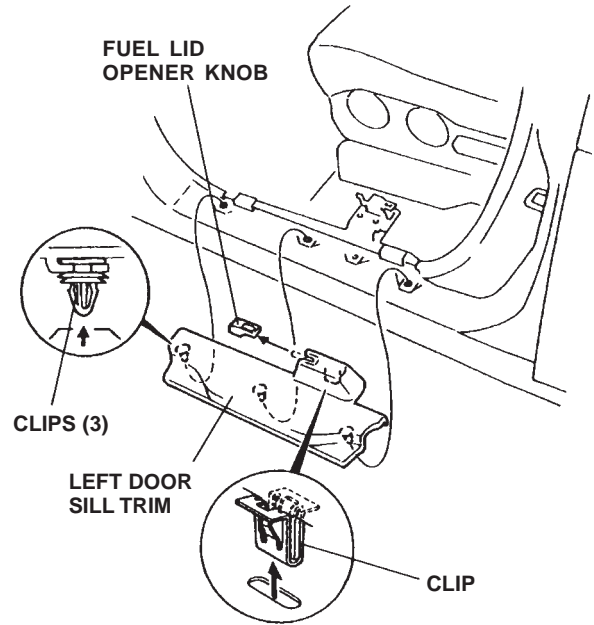

35. Pry up on the clips, and remove the left front door sill trim. Be careful not to damage the clips.
36. Pull up the driver's side front opening trim, and unscrew the clip that secures the kick panel. Remove the kick panel by pulling it out toward you.

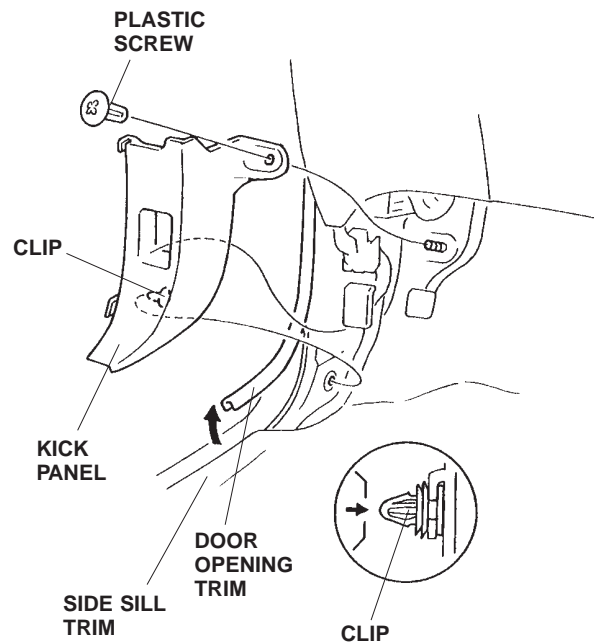

37. Remove the driver's dashboard lower cover (one self-tapping screw and three clips). On an EX or EX-L model, unplug the climate control 2-pin connector from the sensor.

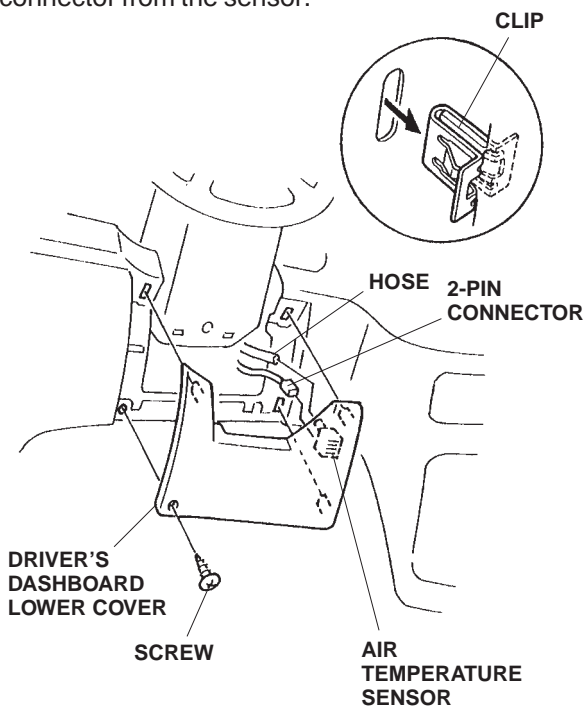

38. Pull out on the left side panel to release the five retaining clips. Unplug the vehicle connectors, and remove the left side panel.

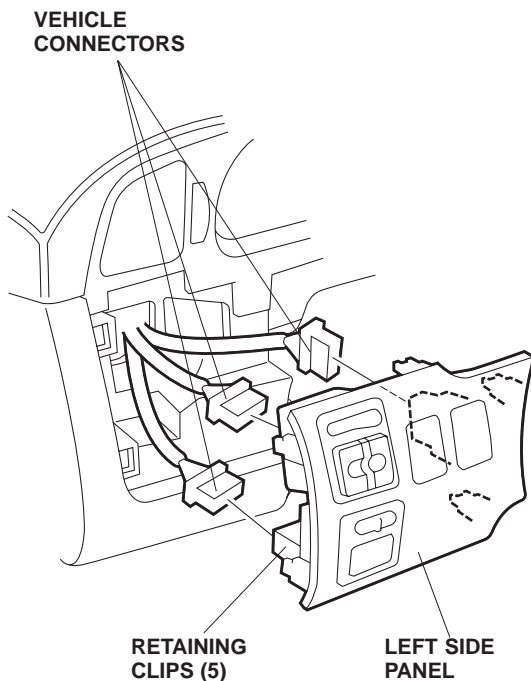

39. Lower the steering wheel tilt lever. Remove the upper and lower steering column cover (three screws and seven clips). Gently push on the seven retaining tabs, and separate the two steering column covers. Take care not to damage the clips.

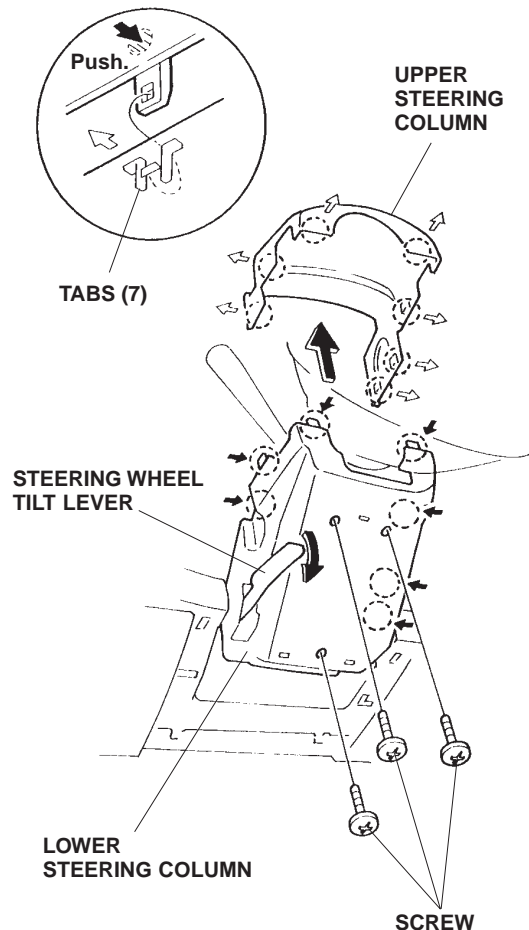

40. Unplug the vehicle harness 14-pin connector from the light switch. Route harness B down through the left side of the steering shaft, and connect the 14-pin connectors from harness B in between.

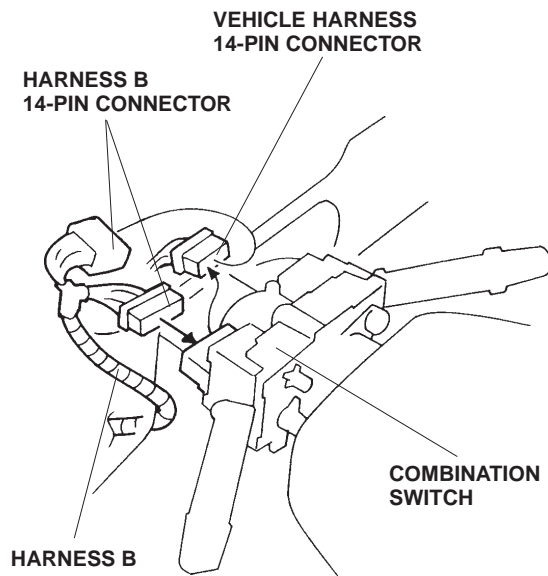

41. Plug the harness B 6-pin connector into the driver's side fuse box. Attach the 2A fuse label to the fuse case of harness B.

Without Seat Heaters:

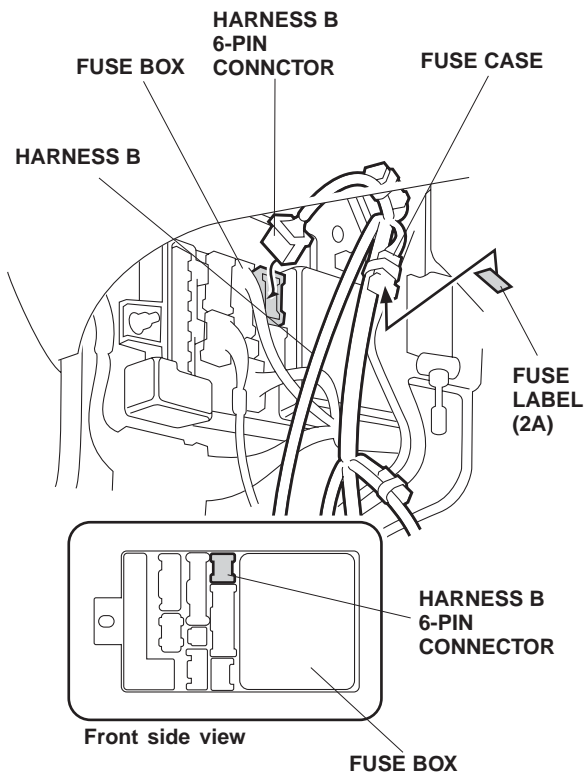

- With Seat Heaters:** Remove the dummy connector from the 6-pin connector taped to harness B. Unplug the seat heater harness 6-pin connector from the fuse box, and plug it into the 6-pin connector taped to harness B.

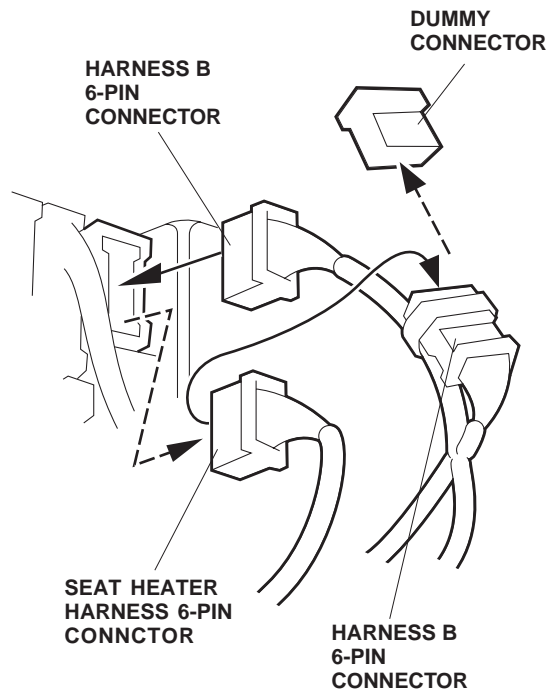

42. Route the harness B 8-pin connector to the body panel opening.

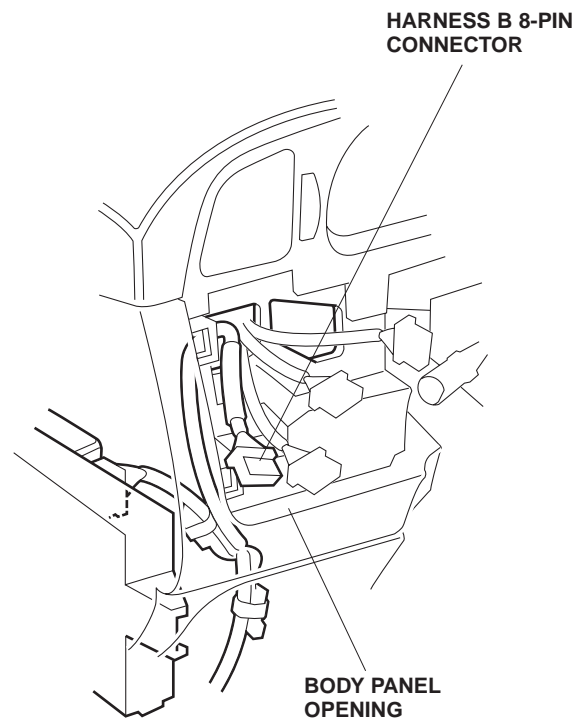

43. Remove the bolt that fastens the vehicle main relay bracket to the steering shaft, and attach relay B with the this bolt.

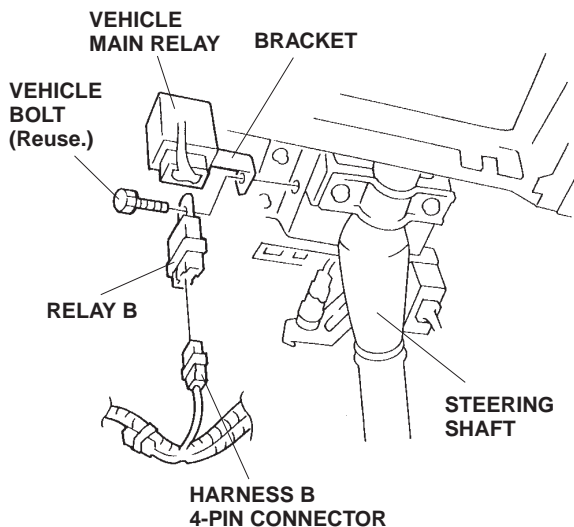

44. Plug the harness B 4-pin connector into relay B.
45. Route harness B over the steering shaft.

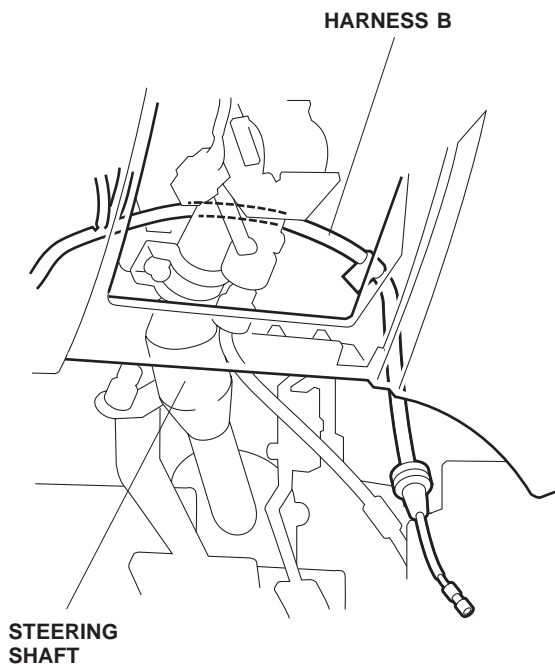

46. Above and to the right of the accelerator pedal, cut out and remove the insulator, then push the grommet concealed under the insulator out into the engine compartment.

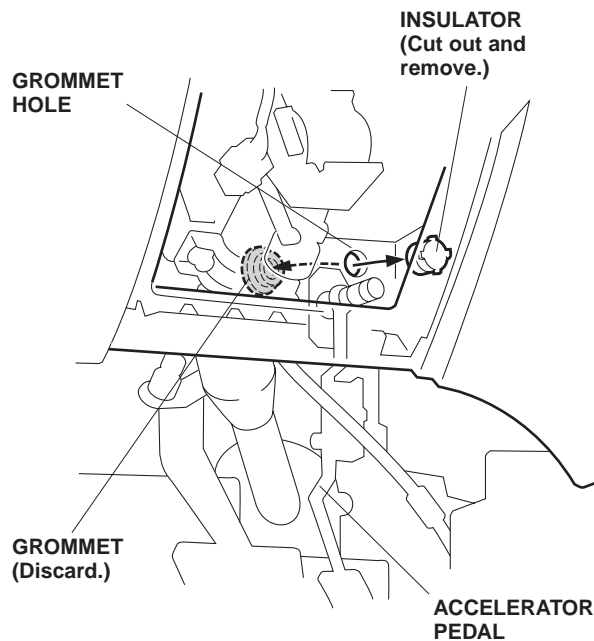

If the vehicle you're working on is equipped with an optional hood switch, go to step 49; otherwise, continue with step 47.

47. Route the 1-pin connector of harness B out into the engine compartment through the grommet hole.

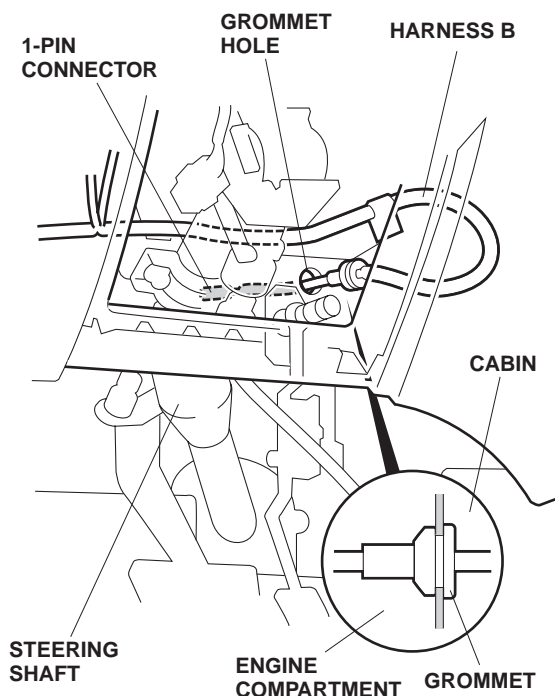

48. Inside the engine compartment, plug the 1-pin connector from harness B into the 1-pin connector of harness A. Go to step 50.

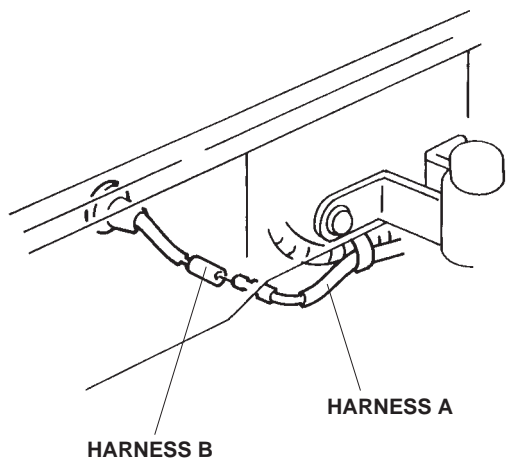

49. Remove the grommet, locate the two 1-pin connectors taped to the hood switch harness near the grommet. Remove the tape to free the 1-pin connectors.

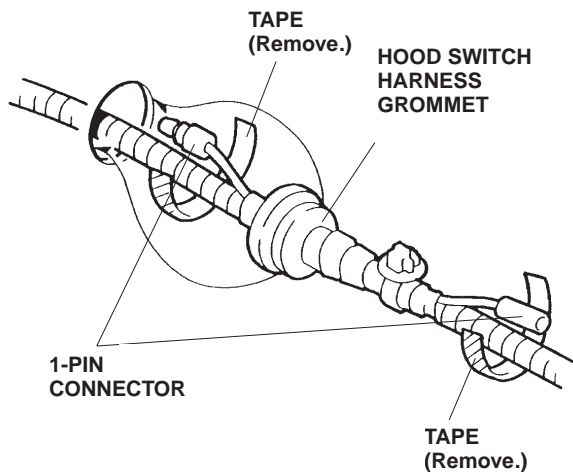

50. Plug the 1-pin connectors from the fog light harness in between the 1-pin connectors you freed on the hood switch harness. Wrap electrical tape around each of the 1-pin connectors to secure them to the harness. (One connector is inside the cabin, and the other is inside the engine compartment.) Reinstall the grommet.

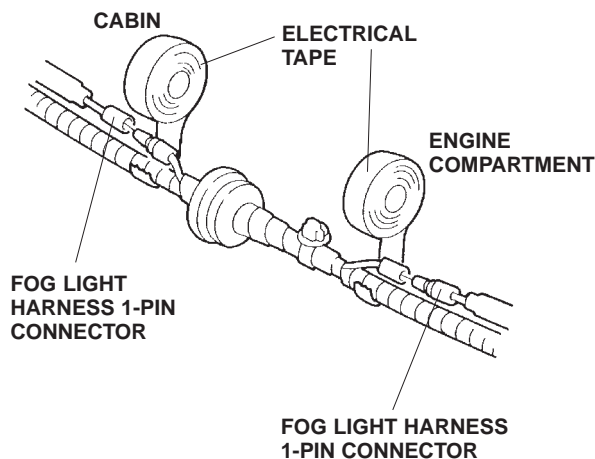

51. Remove the bolt that fastens the air duct, and install the wire clip with this bolt.

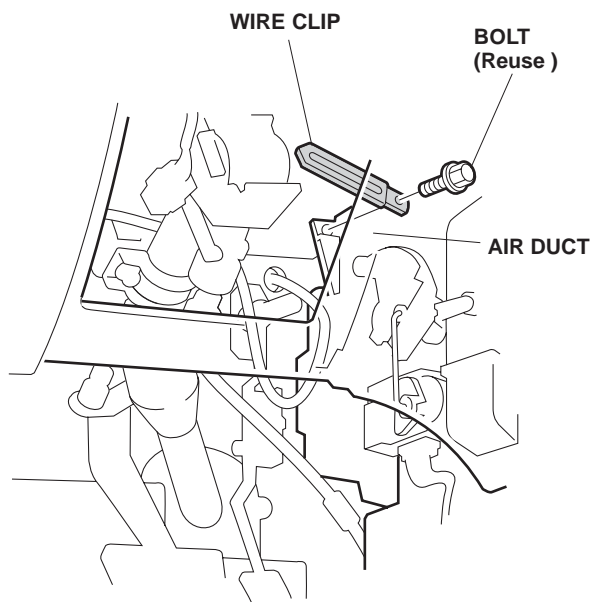

52. Secure harness B to the vehicle harness with two wire ties on each side of tag "B" as shown.

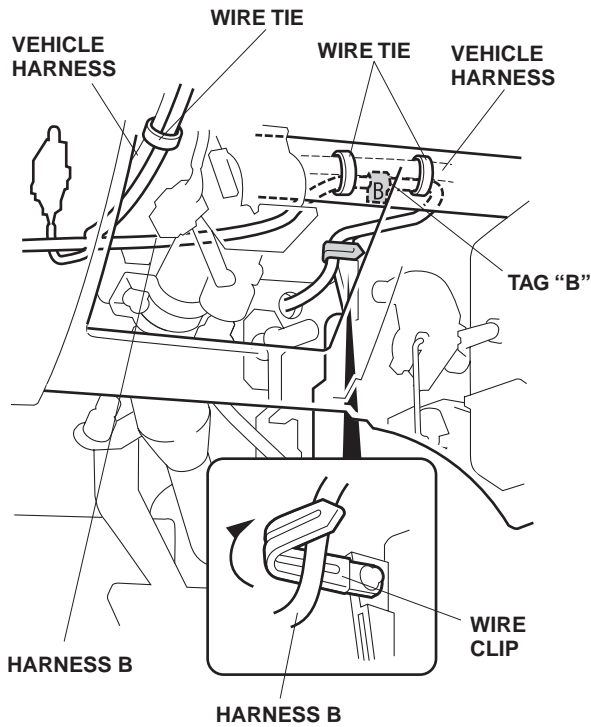

53. Fold the wire clip around harness B. Secure harness B to the vehicle harness with one wire tie.
54. Secure harness B to the vehicle harness with three wire ties in the areas shown.

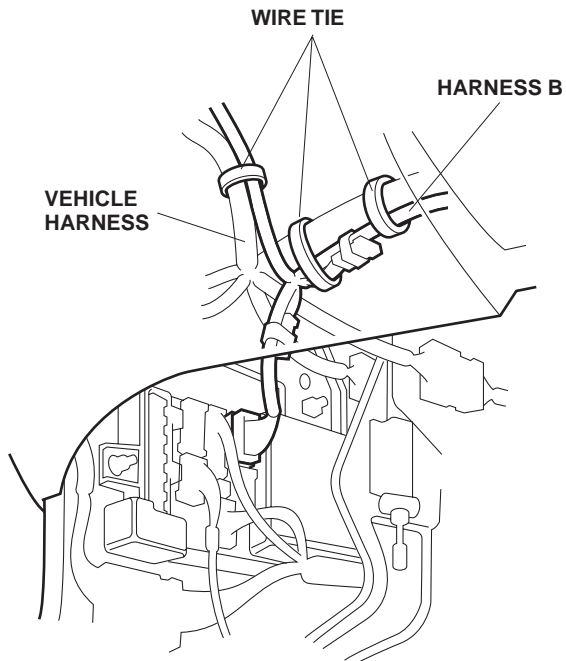

55. Remove the left switch cover (two retaining tabs) from the left side panel.

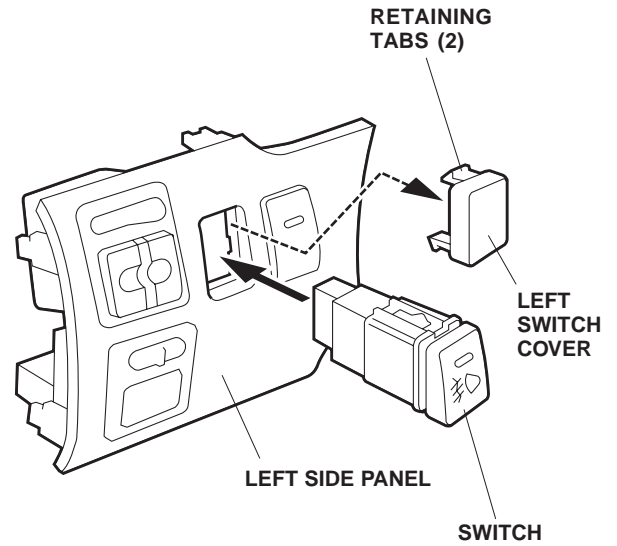

56. Install the switch in the left side panel.
57. Secure harness B to the vehicle harness with one wire tie.

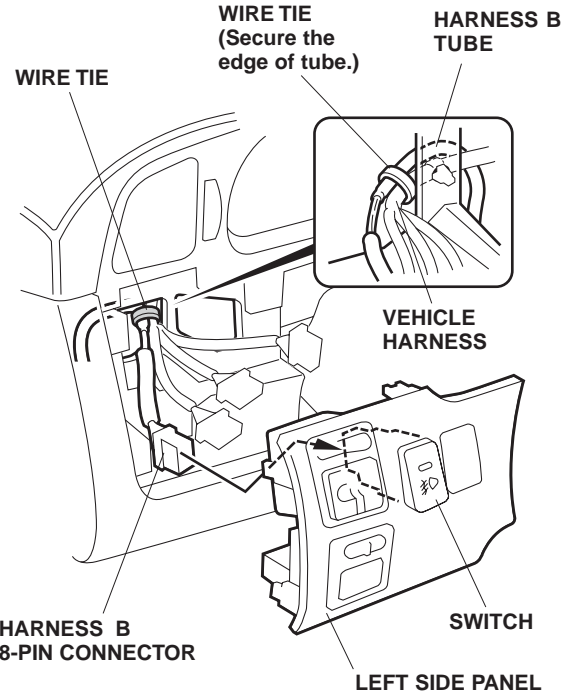

58. Connect the harness B 8-pin connector to the switch. Plug in the vehicle connectors, and reinstall the left side panel.

59. Check that all wire harnesses are routed properly and all connectors are plugged in.
60. Reinstall all removed parts.
61. Reconnect the negative cable to the battery.
62. Enter the customer's radio anti-theft code, and reset the station presets.
63. Reset the clock.

NOTE: Whenever the battery is disconnected, the driver's window AUTO function is disabled.

64. Start the engine. Push down on the driver's window switch until the window is fully open.
65. Pull up on the driver's window switch to close the window completely, then hold the switch for a second or 2 more.
66. Check the operation of the driver's window AUTO function.

Fog Light Aiming Adjustment

67. Remove the bolt and the clip, and pull down the inner fender.

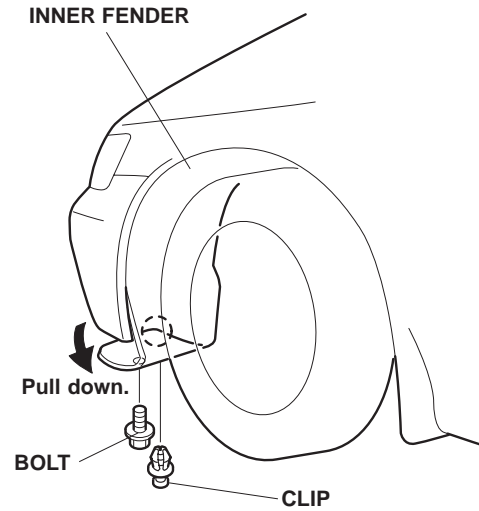

68. Adjust the fog lights:

- Adjust the aim according to local laws and regulations.
- To adjust, turn the adjustment screw in or out until the correct aim is obtained.

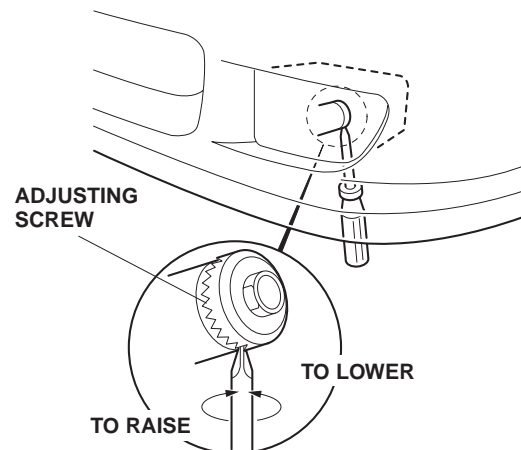

USE AND CARE

How to Operate Fog Lights

- Turn the light switch to the “on” position (headlights on low beam).
- Press the fog light switch (the indicator comes on).
- If the fog lights don’t come on, check the fuse and all the connectors, including the ground cable and the fusible link.

NOTE: The fog light lenses can cloud when the outside temperature is cold; this is normal and should go away in warm weather.

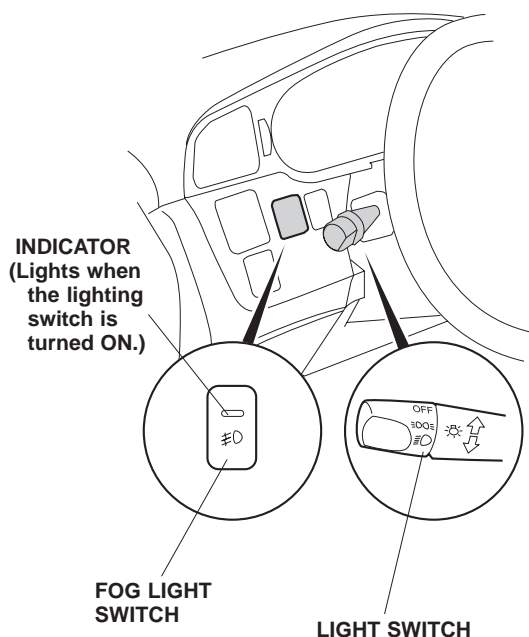

Replacing the Bulb

NOTE:

- Use only a Genuine Honda halogen light bulb of specified wattage.
- Do not touch the bulb. Oily or greasy substances on the bulb can shorten its service life due to the heat produced when the bulb is turned on. If the bulb is accidentally touched, wipe it clean with a clean, soft cloth that has been dampened with denatured alcohol or a mild detergent solution.
- Align the tab on the fog light with the cutout in the bulb socket when installing the new bulb. If not aligned, there is possibility that the fog light may annoy the oncoming driver's.

1. Remove the bolt and the clip, and pull down the inner fender.

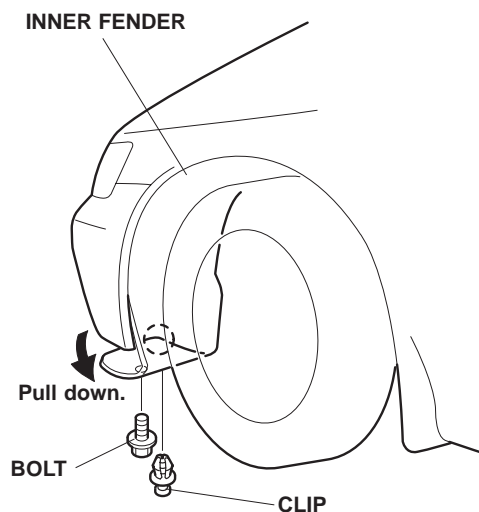

2. Unplug the connector from the fog light.
3. Remove the two screws that fasten the fog light, and pull the light out toward you.

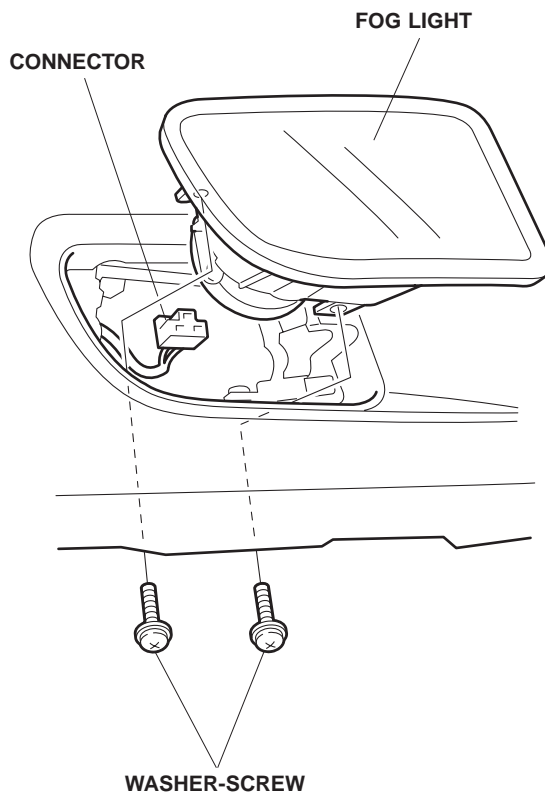

4. Pull out the cover. Release the spring pin, and remove the socket.

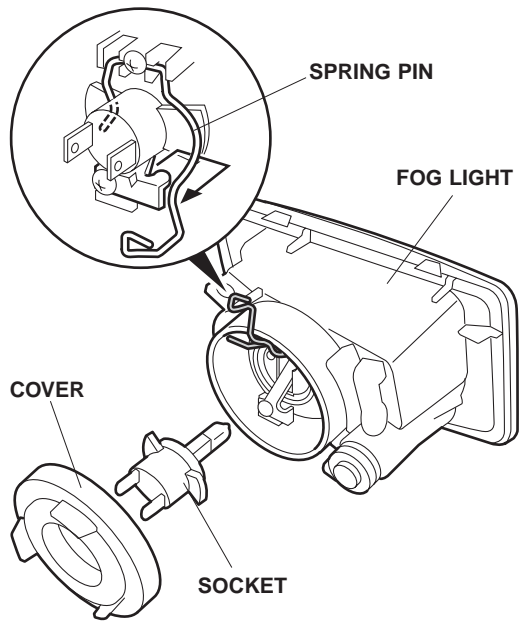

5. Remove the bulb from the socket.

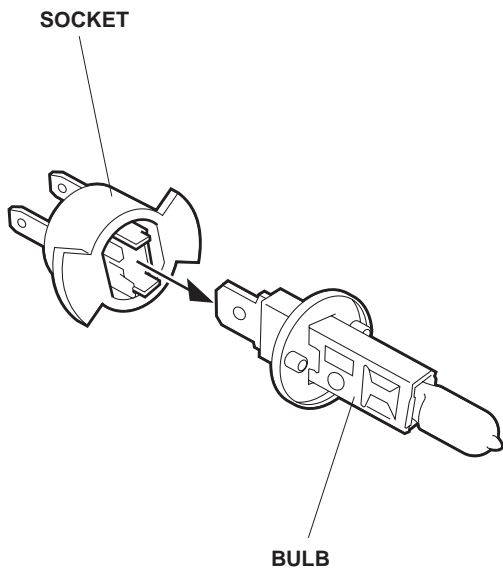

6. Install the new bulb into the socket.

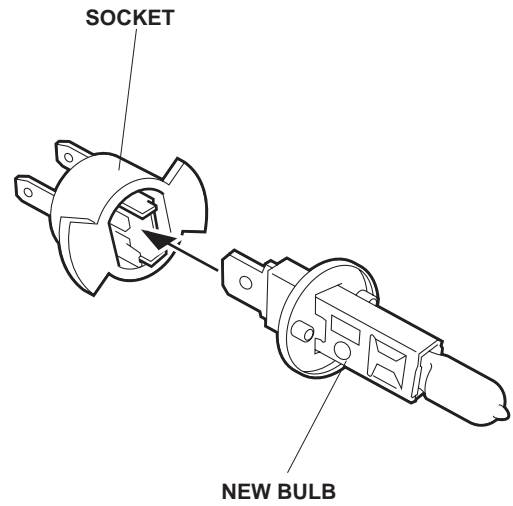

7. Align the tabs of the socket with the recess of the fog light, and insert the new socket into the fog light.

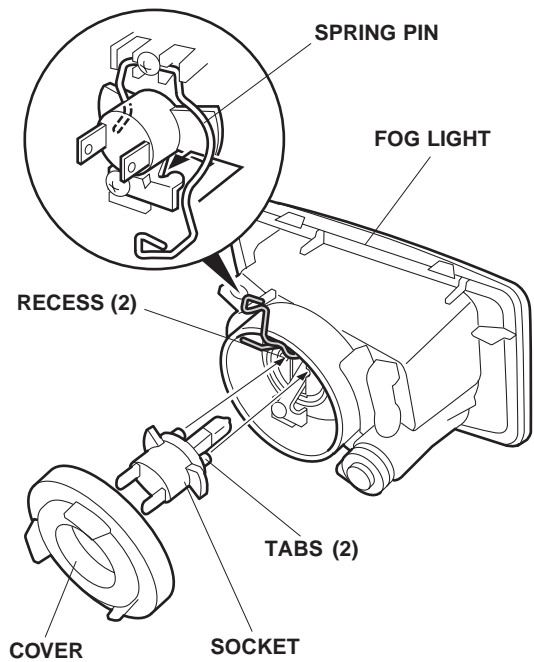

8. Lock the spring pin, and reinstall the cover.
9. Reinstall the fog light, and reconnect the connector.
10. Check the operation of the fog light, and adjust the aiming if necessary.

REPLACING A FUSE

To replace a fuse, remove the cover from the fuse holder taped to the fog light harness, install a new 20A or 2A fuse, as required, and reinstall the cover.

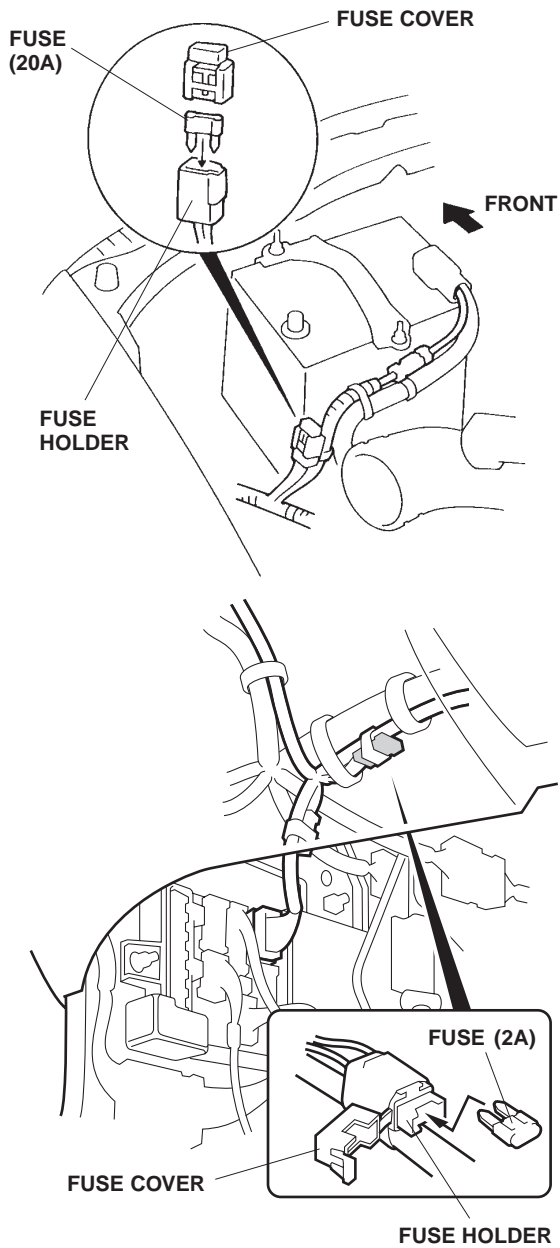

SPECIFICATIONS

Bulb: 12V-55 W
(P/N 34901-SZ3-0000)

Fuse: 20A
(P/N98200-42000)
2A
(P/N08V66-S04-A000-20)

CIRCUIT DIAGRAM

FRONT FOG LIGHT

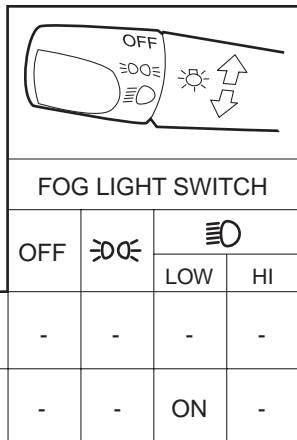
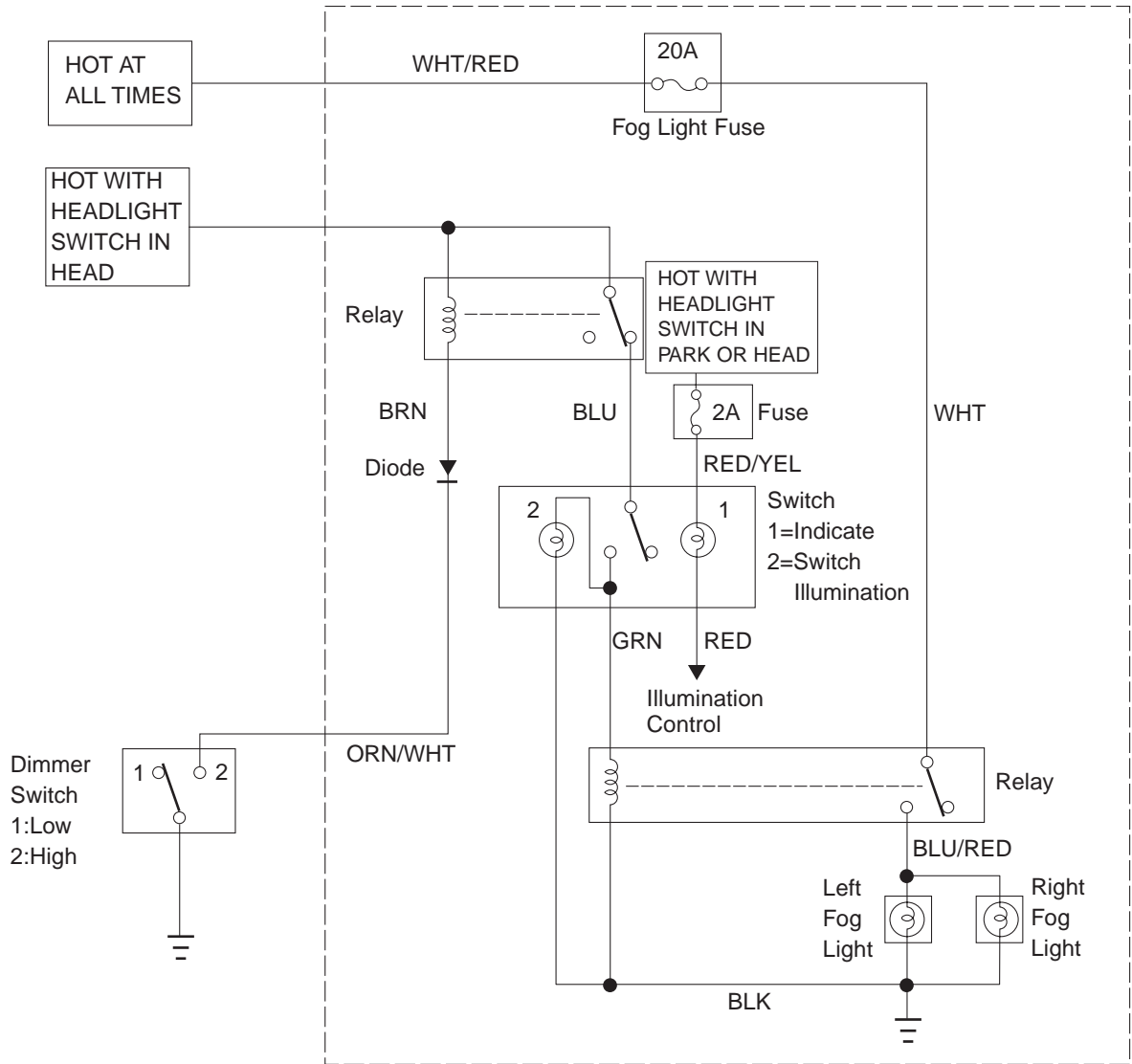

BLK	BLACK	BRN	BROWN
YEL	YELLOW	ORN	ORANGE
BLU	BLUE	PUR	PURPLE
GRN	GREEN	NAT	NATURAL
RED	RED	PNK	PINK
WHT	WHITE	GRY	GRAY
LT BLU	LIGHT BLUE	LT GRN	LIGHT GREEN