



INSTALLATION INSTRUCTIONS

Accessory
GOLD EMBLEM KIT

Application
ODYSSEY

Publications No.
All 33175
Issue Date
JULY 2006

PARTS LIST

**Gold Emblem kit (sold separately):
P/N 08F20-SHJ-100E**

Front gold "H" emblem

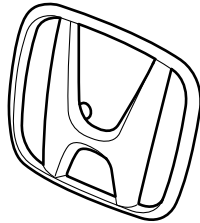

Rear gold "H" emblem

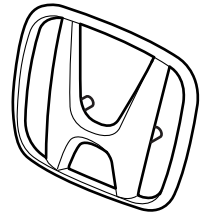

Rear gold
"ODYSSEY" emblem

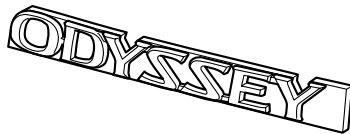

**Gold "TOURING" Emblem kit (sold separately):
P/N 08F20-SHJ-100A**

Rear gold
"TOURING" emblem

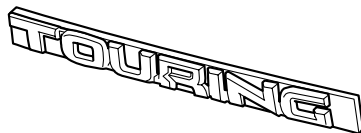

TOOLS AND SUPPLIES REQUIRED

Phillips screwdriver
Flat-tip screwdriver
Diagonal cutters
Isopropyl alcohol
Shop towel
String
Masking tape
Blanket

INSTALLATION

Customer Information: The information in this installation instruction is intended for use only by skilled technicians who have the proper tools, equipment, and training to correctly and safely add equipment to your car. These procedures should not be attempted by "do-it-yourselfers."

NOTE:

- Be careful not to damage the body finish when you remove and install the emblems.
- This emblem kit should be installed only when the ambient air temperature is 60°F (15°C) or above.
- To allow the adhesive to "cure", do not wash the vehicle for 24 hours.

Installing the Front Gold "H" Emblem

1. Open the hood, and remove the bulkhead cover (10 expansion clips).

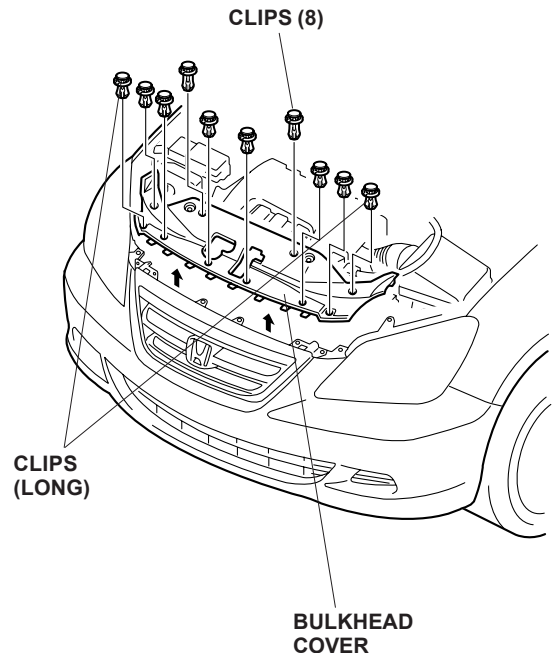

- Remove the front grille (three clips).

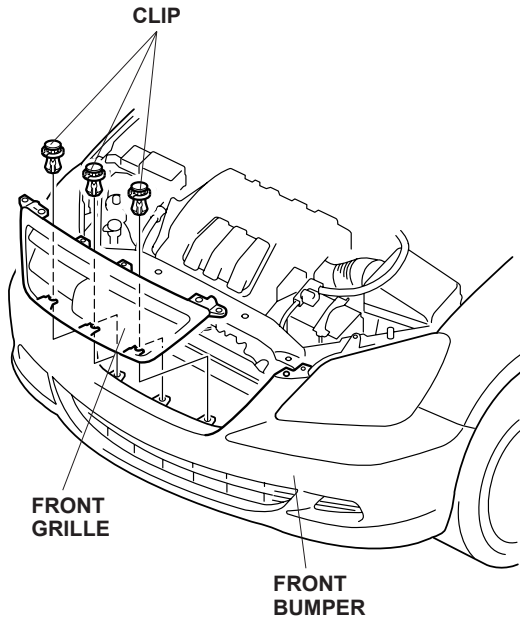

- Remove the front "H" emblem (two screws).

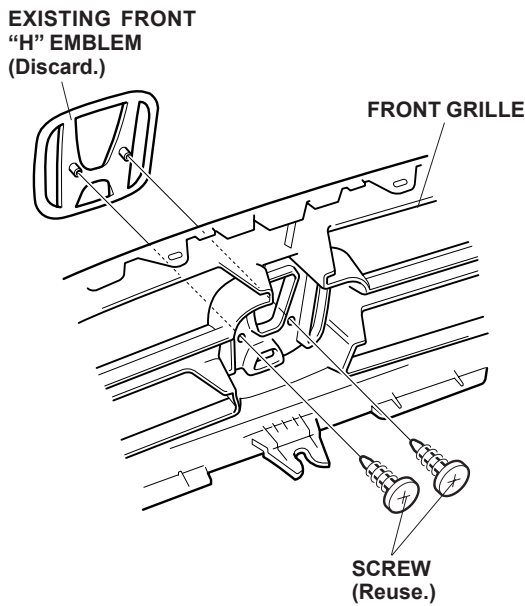

- Align the two pins on the front gold "H" emblem with the holes in the front grille and secure the emblem with the two screws you just removed.

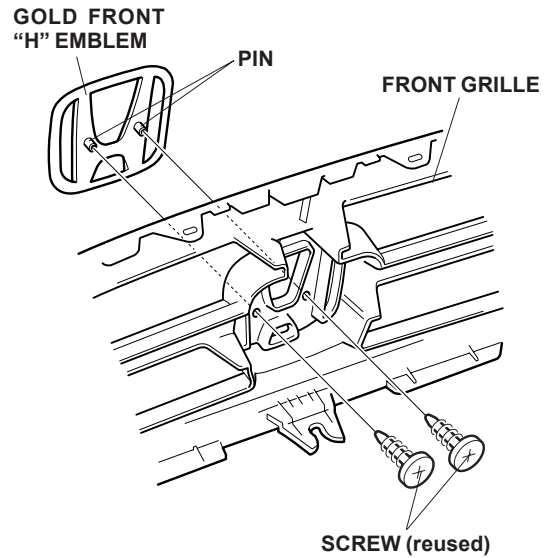

- Reinstall the front grille.

Installing the Rear Gold "H", "ODYSSEY" and "TOURING" Emblems

- Mark the locations of the existing "H", "ODYSSEY" and "TOURING" emblems by applying masking tape along the edges as shown.

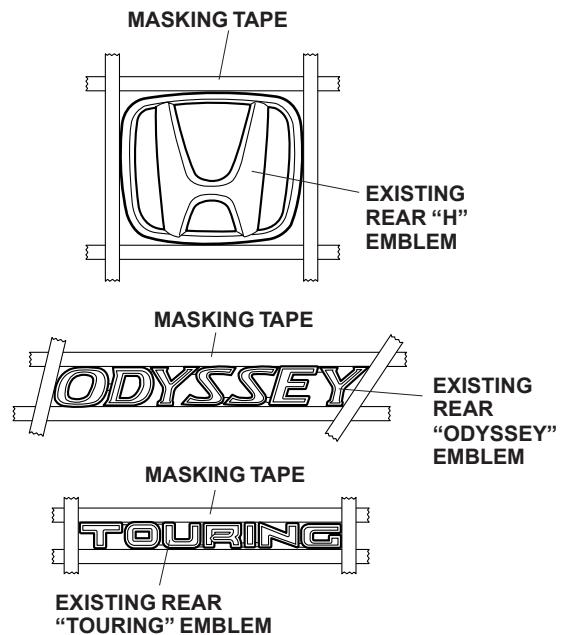

- Remove the "H", "ODYSSEY" and "TOURING" emblems from the body by cutting the outer edges with a piece of string.

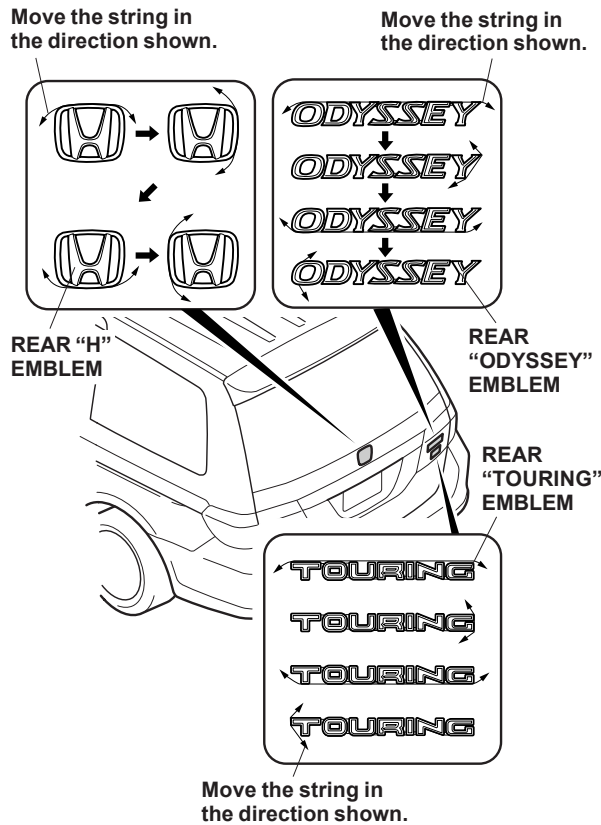

- If any original clips stayed in the body panel, make sure you remove and discard the old clips before attempting to install the emblems.
- Using isopropyl alcohol on a shop towel, clean the areas where the gold "H", "ODYSSEY" and "TOURING" emblems will attach.

- Remove the adhesive backing from the gold "H", emblem; align the tabs on the emblem with the holes in the tailgate. Attach the emblem to the tailgate, and then press the emblem firmly against the tailgate with the palm of your hand for 30 seconds.

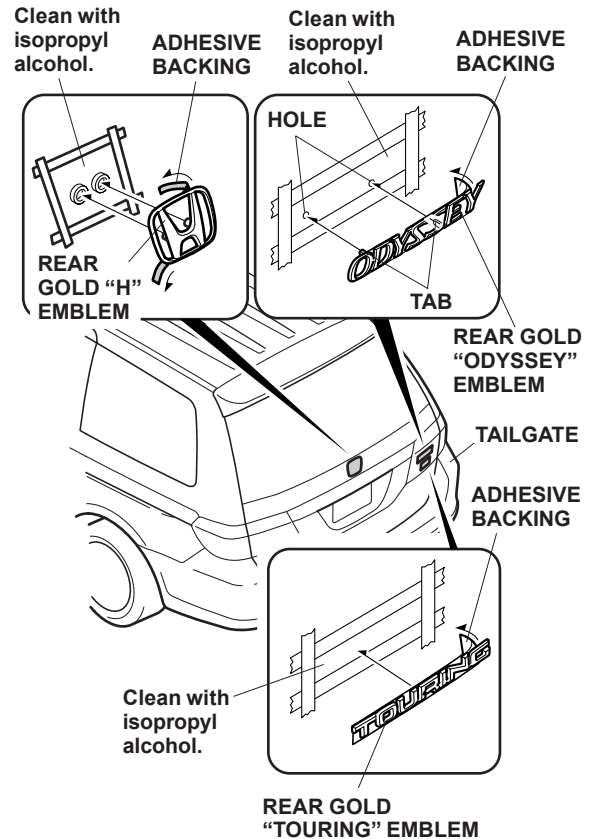

- Remove the adhesive backing from the new "ODYSSEY" emblem; align the tabs on the emblem with the holes in the tailgate. Attach the emblem to the tailgate, and press the emblem firmly against the tailgate with the palm of your hand for 30 seconds.
- Remove the adhesive backing from the new "TOURING" emblem; align the emblem with the masking tape on the tailgate. Attach the emblem, and then press the emblem firmly against the tailgate with the palm of your hand for 30 seconds.
- Remove the masking tape.

NOTE: After the emblem kit is installed, tell your customer not to wash the vehicle for 24 hours to give the adhesive time to cure.