



INSTALLATION INSTRUCTIONS

Accessory
IN-VEHICLE ENTERTAINMENT SYSTEM (DVD BASED)

Application
ODYSSEY

Publications No.
All 24128
Issue Date
OCT 2002

PARTS LIST

**DVD Monitor Kit
P/N 08B23-S0X-100**

Monitor bracket

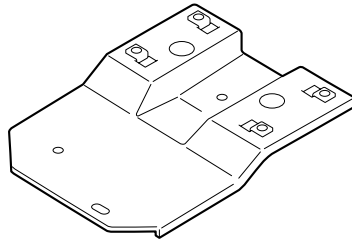

Butterfly bracket

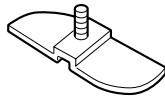

Template

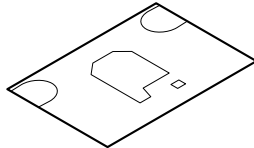

Locknut



2 Washer-screws, 5 x 12 mm



Cushion tape

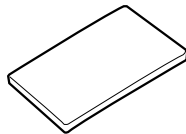

**DVD Cup-to-DIN Kit
P/N 08B23-S0X-100A**

Bezel

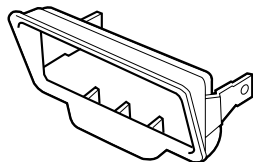

DVD player bracket

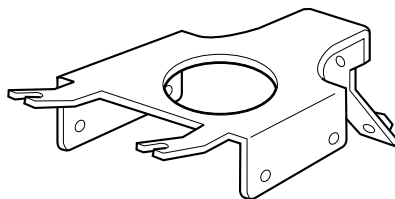

Washer-screw, 5 x 12 mm



2 Flange nuts, 5 mm



***i*-VES DVD Base Unit Kit
P/N 08A23-9E1-010**

DVD player

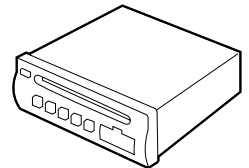

Monitor console

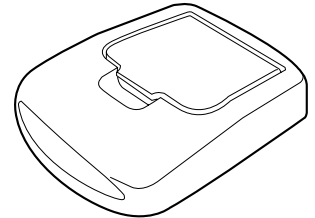

i-VES harness

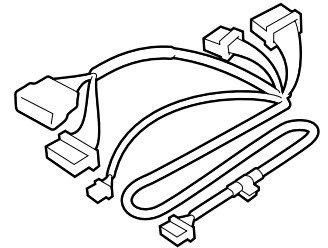

FM modulator

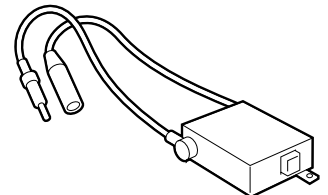

2 Headphones



Remote control

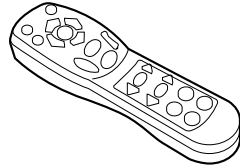

4 Washer-screws, 5 x 12 mm



4 Self-tapping-screws, 4 x 19 mm

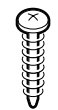

10 Wire ties

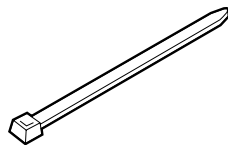

Cushion tape

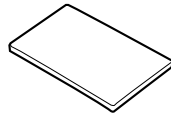

Owner's Manual

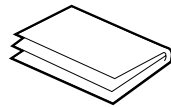

TOOLS AND SUPPLIES REQUIRED

Phillips screwdriver

Flat-tip screwdriver

Ratchet

7 mm, 8 mm, 12 mm, 13 mm, and 14 mm Sockets

10 mm Deep socket

Torx bit (T25)

Torque wrench

Utility knife

Masking tape

Electrical tape

Shop towel

Scissors

Isopropyl alcohol

Piece of wire 3 feet long

Felt-tip pen

Illustration of the *i*-VES Installed on the Vehicle:

Illustration of the DVD Player installed in the beverage holder opening (Navigation System and Player equipped)

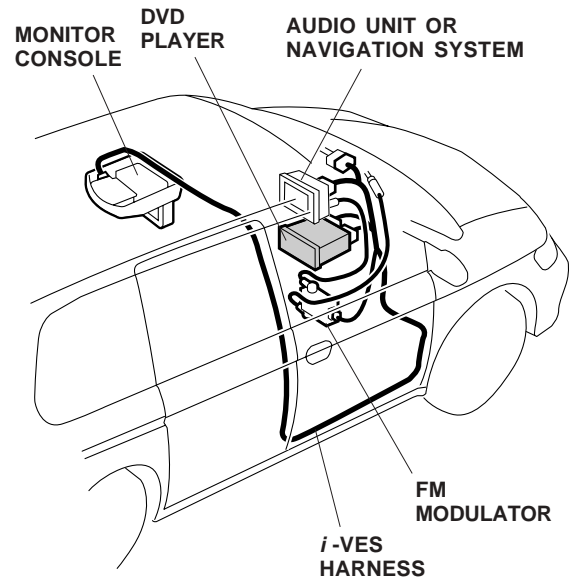
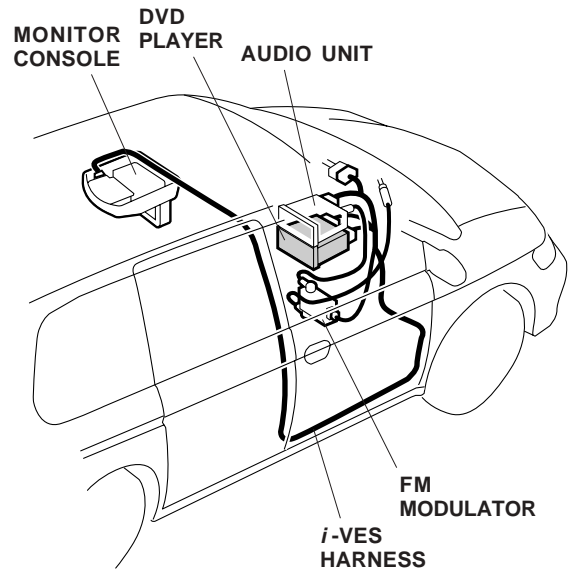

Illustration of the DVD Player installed in the audio unit opening (pocket equipped)



INSTALLATION

Customer Information: The information in this installation instruction is intended for use only by skilled technicians who have the proper tools, equipment, and training to correctly and safely add equipment to your vehicle. These procedures should not be attempted by “do-it-yourselfers.”

1. Make sure you have the anti-theft code for the radio, then write down the frequencies for the preset buttons.
2. Disconnect the negative cable from the battery.
3. Using scissors, cut out the marked areas of the template along the lines.

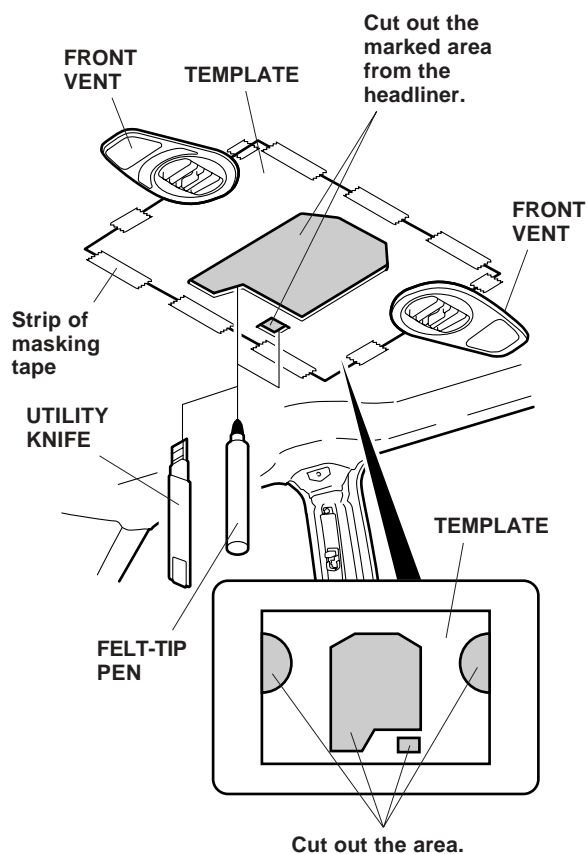

4. Position the template on the headliner at the two front vents, and secure it with masking tape. Mark the headliner as indicated on the template with a felt-tip pen (two places).
5. Remove the template. Using a utility knife, cut out the marked areas of the headliner. Remove and discard the cut pieces of the headliner and the insulation.

6. Remove the center panel:
 - Move the gear selector to the D1 position.
 - Using a small flat-tip screwdriver wrapped with a shop towel, gently pry out and remove the plastic cover.
 - Reach inside the cover hole, and gently pull along the bottom to release the lower clips; then work toward the top to release all 10 clips.
 - Pull out the console panel, unplug the connectors, and remove the panel.

Without Navigation System:

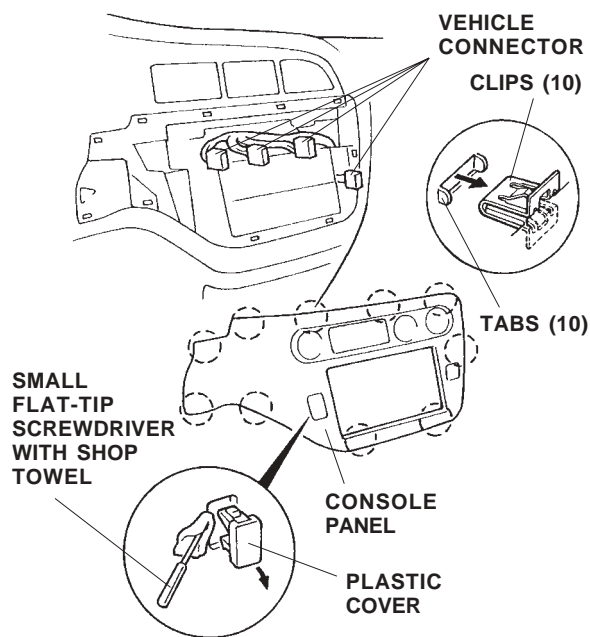

With Navigation System:

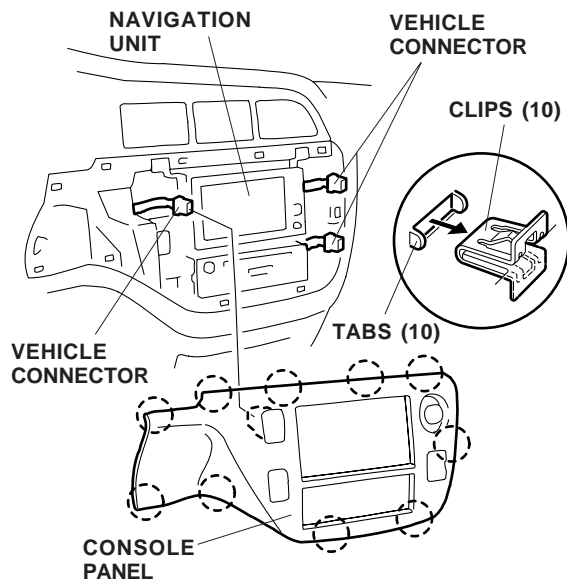

- Remove the audio unit (four bolts, and unplug the vehicle connector and the antenna lead). If equipped, remove the navigation unit (two self-tapping screws and four bolts, and unplug the vehicle connectors and the antenna lead).

Without Navigation System:

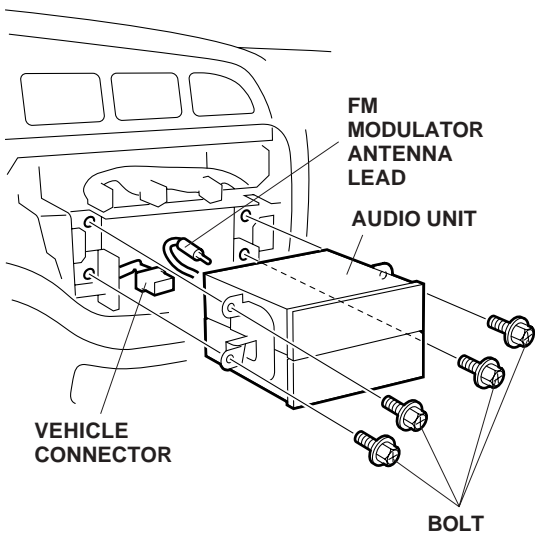

With Navigation System:

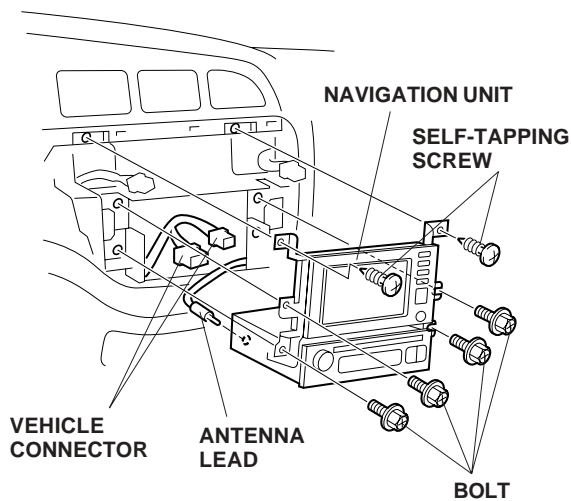

- Open the beverage holder. Using a flat-tip screwdriver, push up on the retaining tab at the bottom, and slide the beverage holder out.

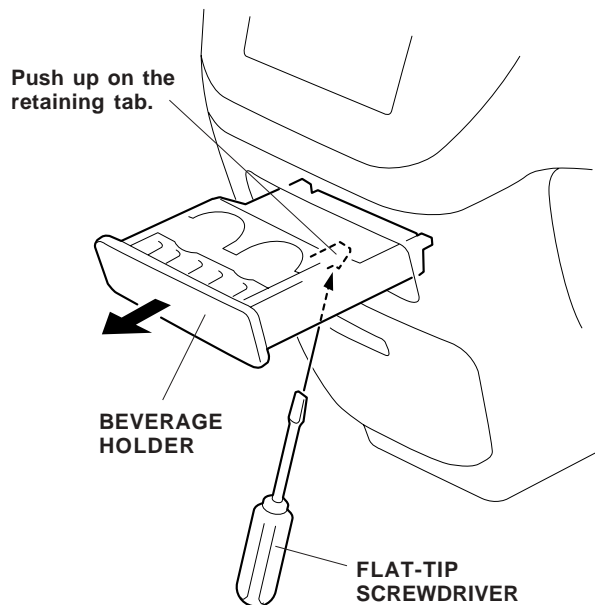

- Remove the center lower trim (one clip on each side and two clips on the front).

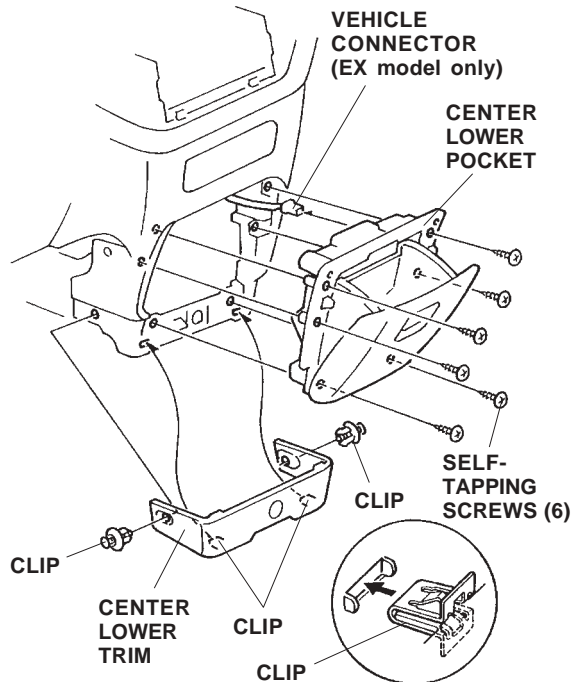

- Open the center lower pocket, and remove the six self-tapping screws. Disconnect the vehicle connector (if equipped), and remove the center lower pocket.

- Disconnect the accessory socket from the accessory socket harness connector, then remove the socket from the instrument panel by unscrewing the socket from the socket holder.

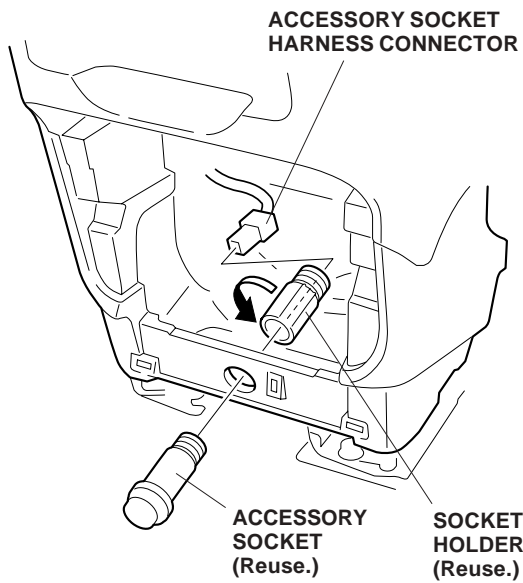

- Remove the center lower console (four self-tapping screws and two bolts).

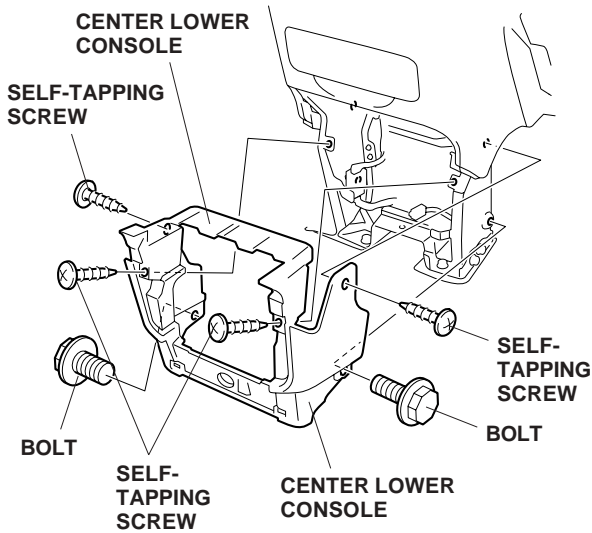

- Remove the three self-tapping screws and two screws that fasten the beverage holder bracket. Pull the beverage holder out toward the center lower pocket opening.

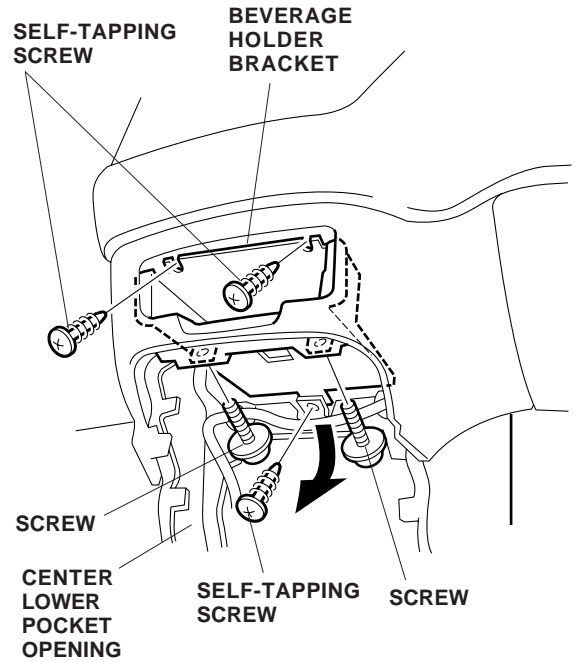

- On the passenger's side of the vehicle, remove the front door side sill trim (lift up to release the three clips).

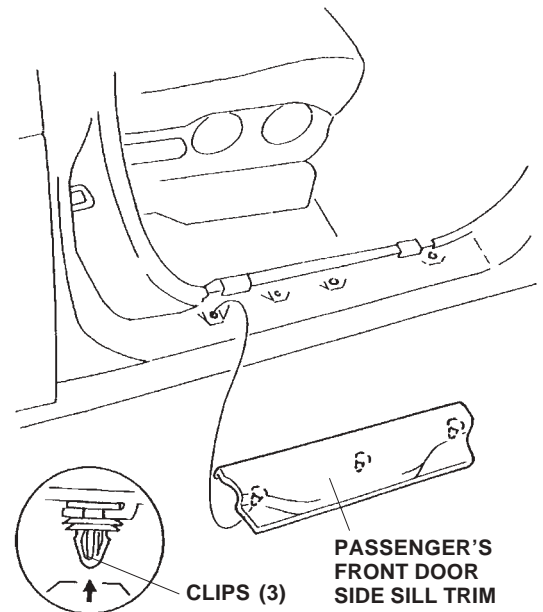

15. Peel up the door opening trim, and remove the passenger's kick panel (one plastic screw and one clip).

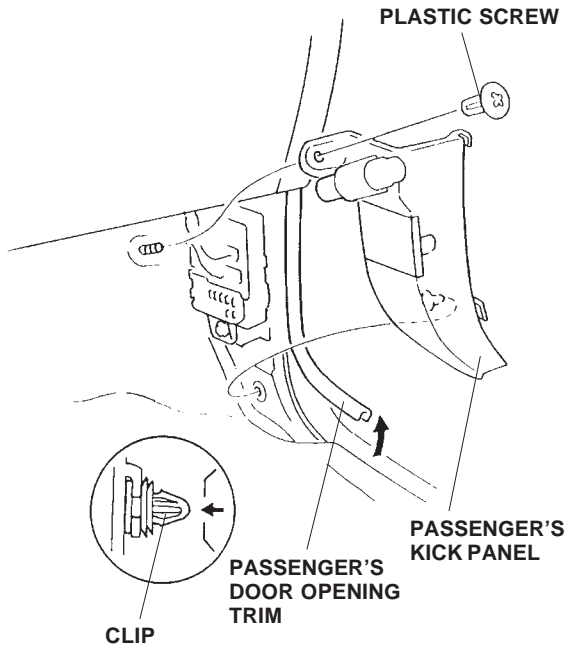

16. On the passenger's side of the vehicle, remove the sliding door sill trim (lift up to release the five clips).

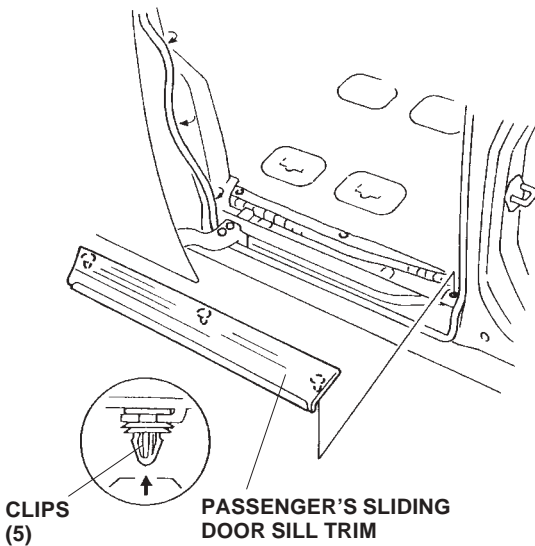

17. Remove the passenger's side center pillar lower trim panel:

- Remove the front door opening trim and the sliding door opening trim around the center pillar lower trim panel.
- Slide the lower anchor cover upward, and remove the front seat belt lower anchor bolt.
- Gently spread open the top of the center pillar lower trim panel to release the two retaining tabs, then release the three clips, and remove the lower trim panel. Take care not to damage the clips and retaining tabs.

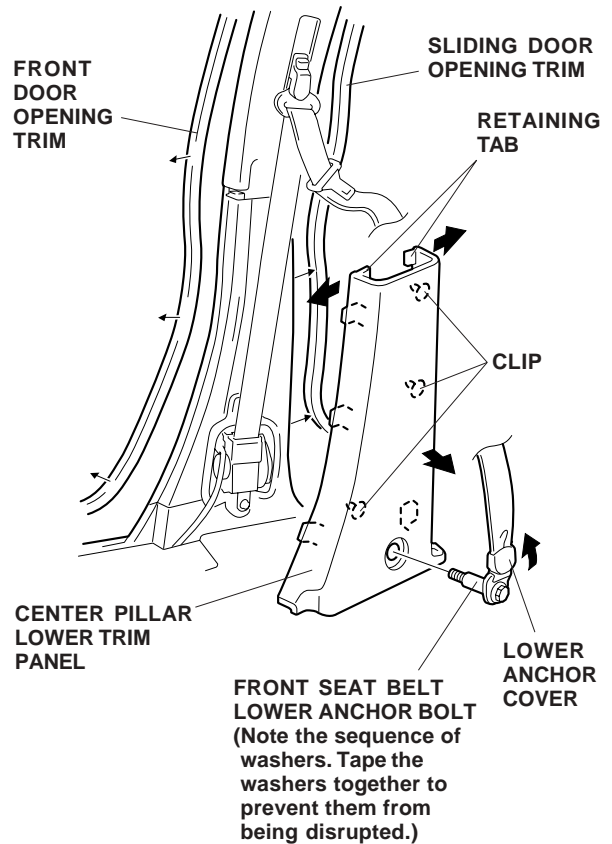

- Release the four retaining tabs that secure the front seat belt upper anchor cover, and remove the anchor cover. Take care not to damage the retaining tabs.

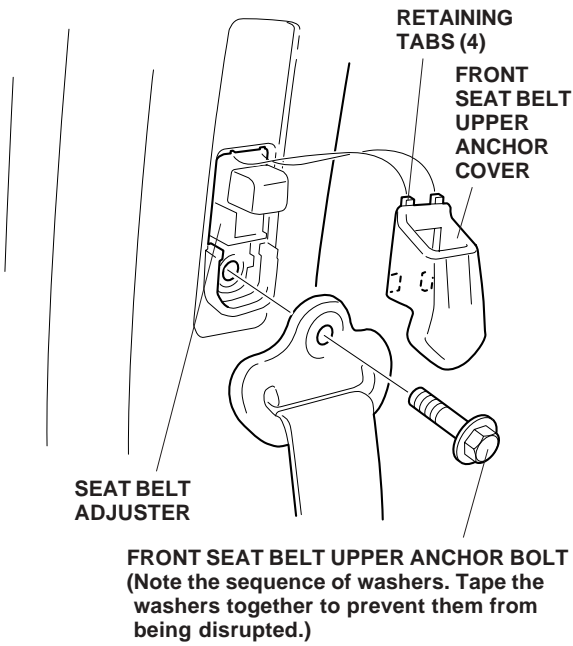

- Remove the front seat belt upper anchor bolt.
- Remove the clip that secures the top of the center pillar upper trim, and remove the trim by sliding it upward. Take care not to damage the clip or the retaining tab.

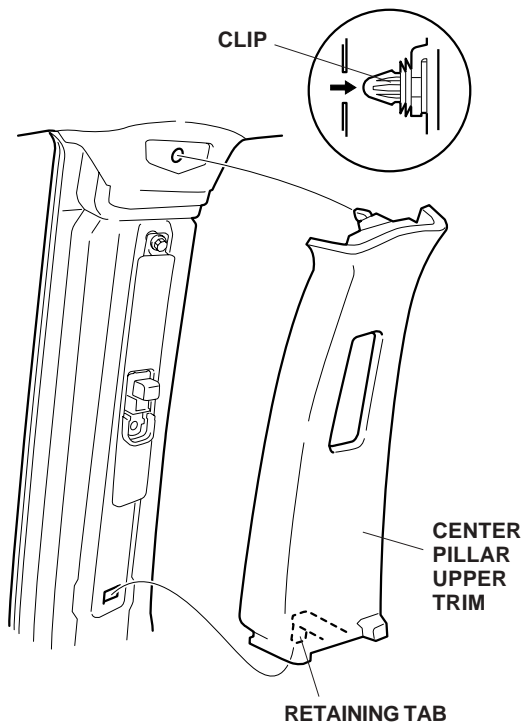

- Lower the glove box by removing the right and left stops.

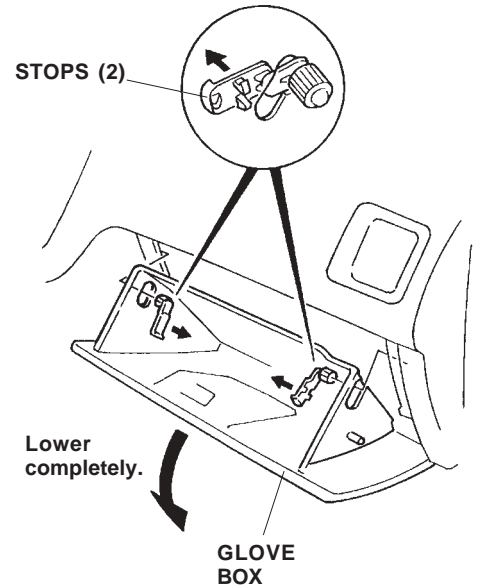

- On the passenger's side of the vehicle, remove the front door opening trim around the front pillar trim. Remove the front pillar trim (four clips).

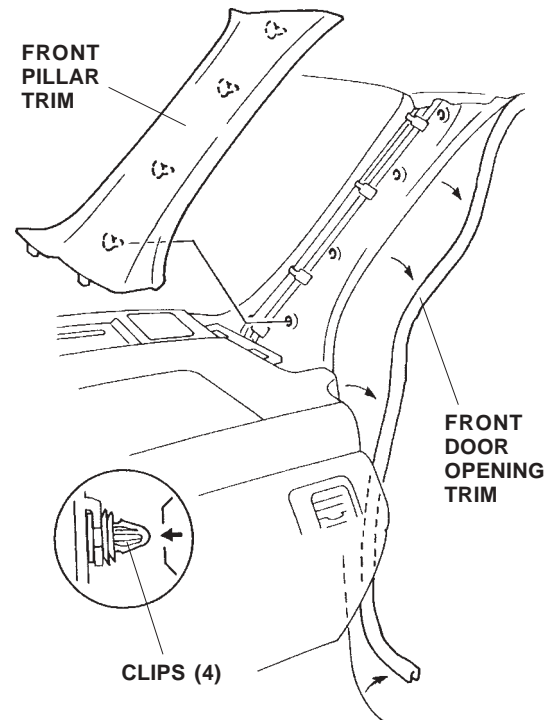

23. Remove the sunvisor on the passenger's side (two Torx bolts, and unplug the connectors).

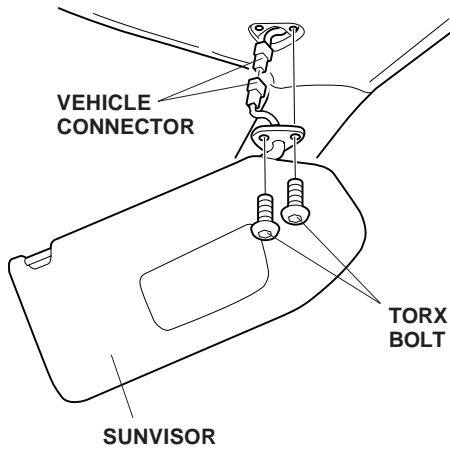

24. On the passenger's side of the vehicle, remove the grab rail (two caps, two Torx bolts, and two washers).

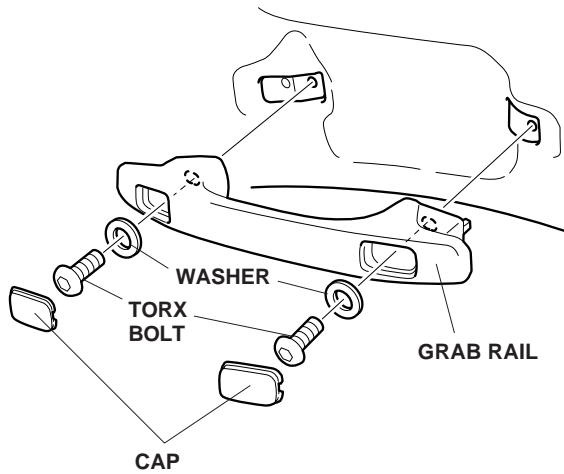

25. On the passenger's side of the vehicle, remove the lens from the roof ceiling vent at the second row by releasing the four retaining tabs. Take care not to damage the retaining tabs.

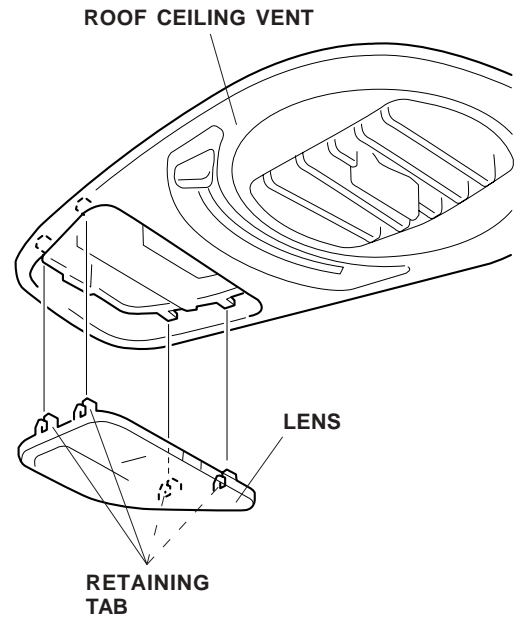

26. Move the vent knob to the closed position, then remove the two screws that fasten the roof ceiling vent. Unplug the vehicle connector, and remove the roof ceiling vent.

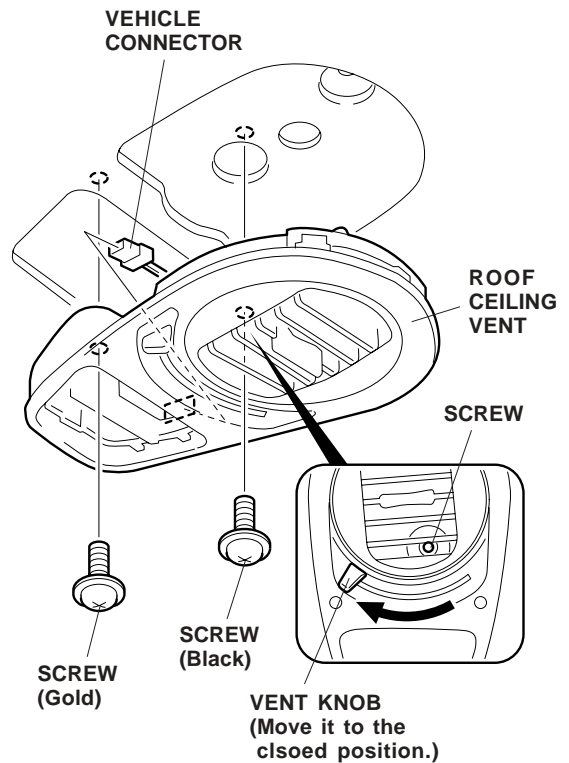

27. Remove the center table arm cover (four clips).
Remove the center table (three nuts).

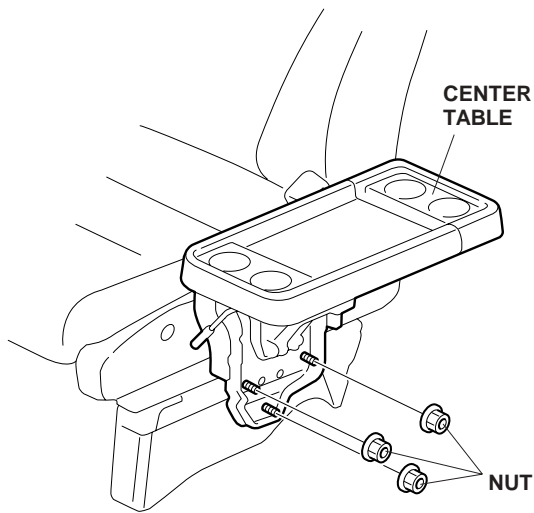

Routing the *i*-VES Harness and Installing the Monitor Console

28. Using isopropyl alcohol on a shop towel, thoroughly clean the area where the cushion tape will attach. Attach the cushion tape to the edge of the vehicle frame.

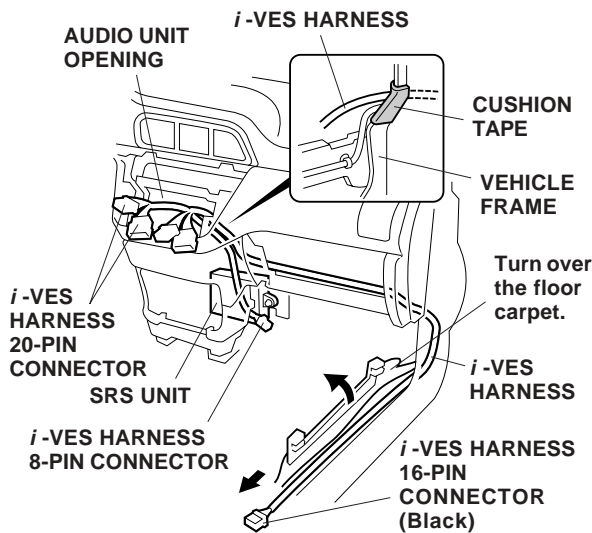

29. Route the *i*-VES Harness:

- Route the *i*-VES Harness 16-pin connector (black) from the audio unit opening through the glove box opening and along the passenger's door to the right center pillar.
- Route the *i*-VES Harness 8-pin connector from the audio unit opening to the SRS unit.

30. Continue routing the *i*-VES harness 16-pin connector up the center pillar.

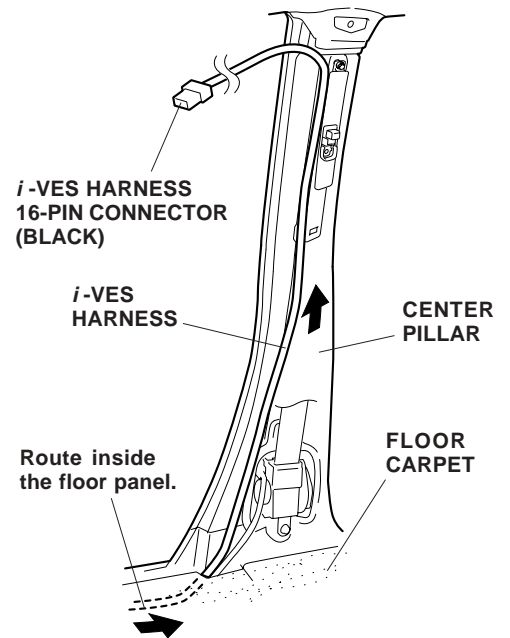

31. Wrap the piece of wire around the *i*-VES harness 16-pin connector. Using electrical tape, secure the wire to the connector so that the end of the wire will not get caught. Pull the 16-pin connector behind the headliner and out of the small cutout until the harness clip comes through the cutout. Remove the tape and the wire.

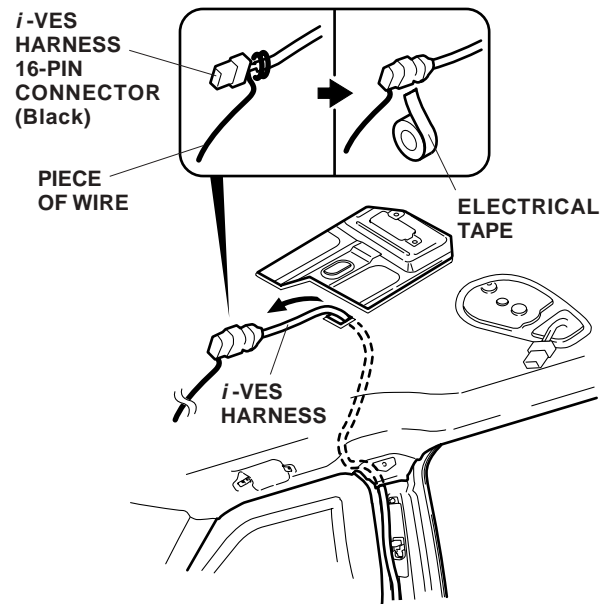

32. Get the butterfly bracket. Insert the butterfly bracket into the elongated hole in the roof panel, then turn it clockwise to lock it into position.

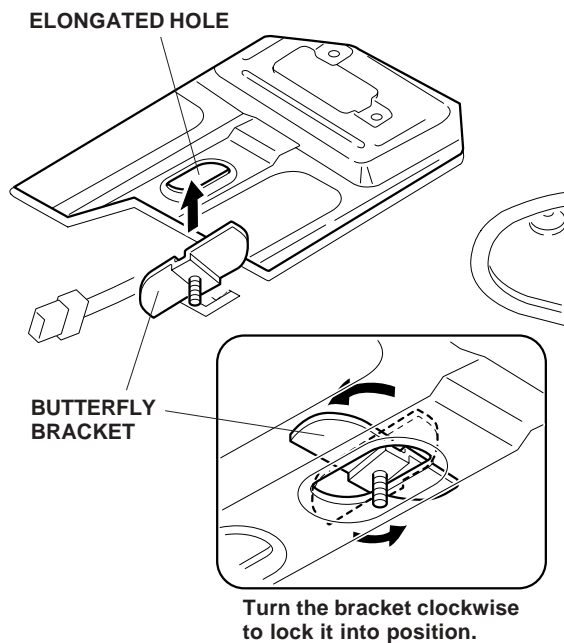

33. Position the monitor bracket on the roof panel, install the locknut onto the butterfly bracket, and install the two 5 x 12 mm washer-screws. Tighten the locknut and the washer-screws securely.

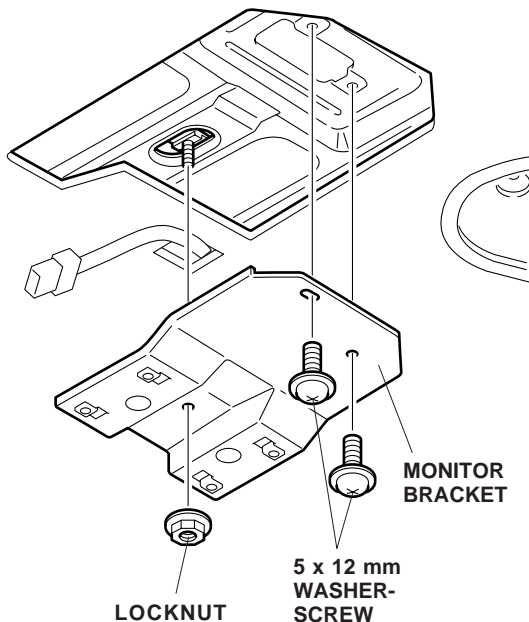

34. Connect the *i*-VES harness 16-pin connector (black) to the monitor console, then secure the monitor console to the monitor bracket with the four 4 x 19 mm self-tapping screws. Secure the harness clip of the *i*-VES harness to the rib of the monitor console as shown.

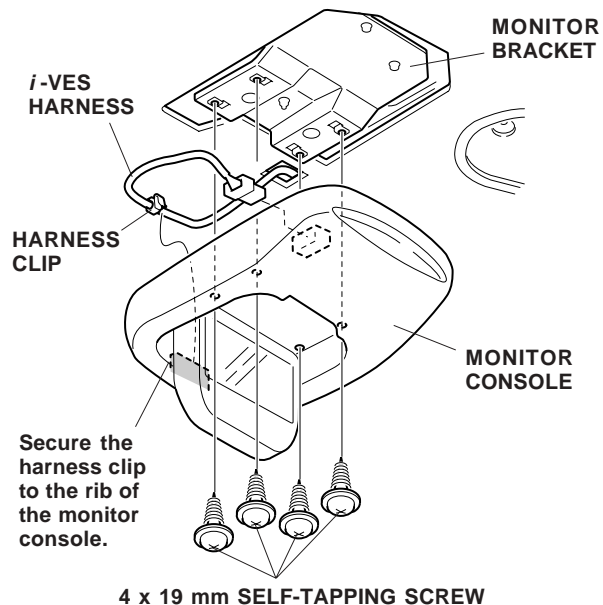

35. Secure the *i*-VES harness to the front seat belt shoulder anchor adjuster with two wire ties in the areas shown. Check that the harness and wire ties do not interfere with the operation of the seat shoulder anchor adjuster.

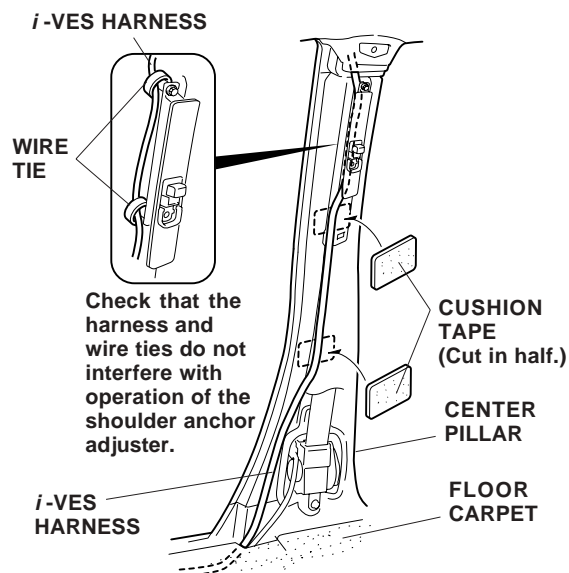

36. Using isopropyl alcohol on a shop towel, thoroughly clean the areas where the cushion tapes will attach. Using scissors, cut the cushion tape in half. Secure the *i*-VES harness to the center pillar with the two pieces of cushion tape in the areas shown.

37. Along the door opening, secure the *i*-VES harness to the vehicle harness with two wire ties in the areas shown.

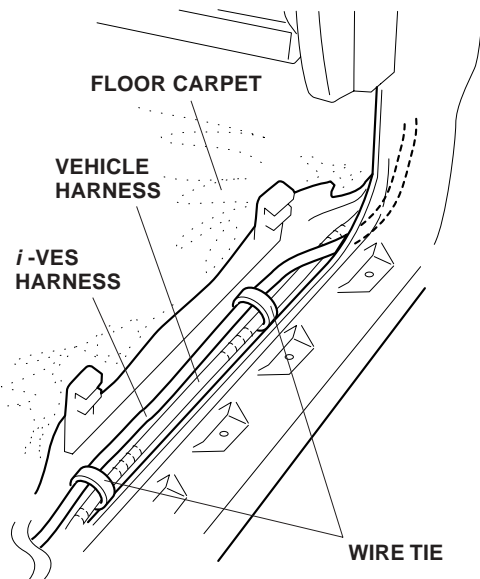

38. Near the fuse box, secure the *i*-VES harness to the vehicle harness with one wire tie. Make sure you do not secure the *i*-VES harness to the yellow SRS harness.

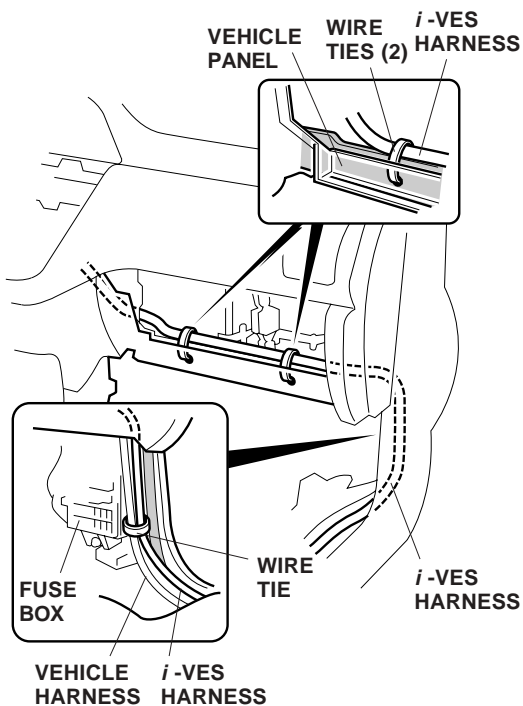

39. In the glove box opening, secure the *i*-VES harness to the vehicle panel with two wire ties.

40. Route the *i*-VES harness 20-pin connectors and 16-pin connector behind the vehicle frame and out through the audio unit opening as shown.

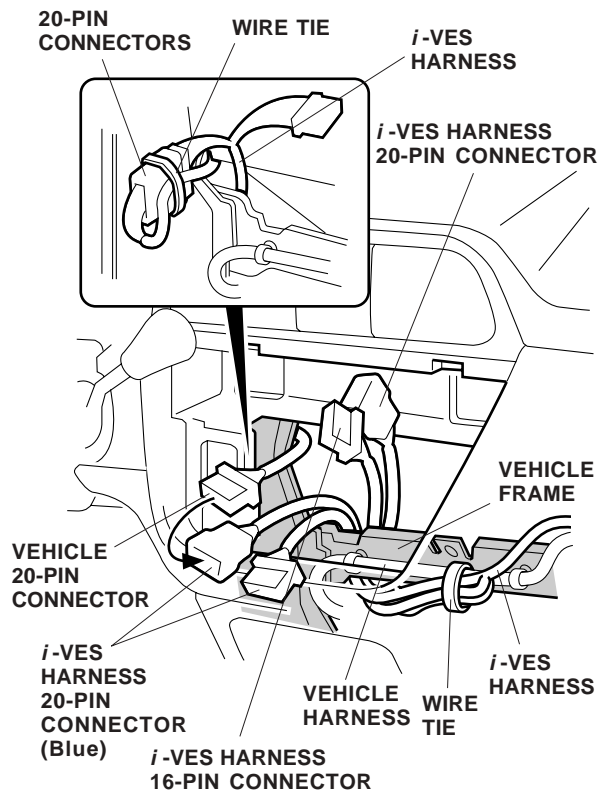

41. Connect the *i*-VES harness 20-pin connector (blue) to the vehicle harness 20-pin connector.
42. Secure *i*-VES harness to the vehicle harness with two wire ties.

Installing the FM Modulator

43. Turn over the floor carpet. Plug the *i*-VES harness 8-pin connector into the FM modulator.

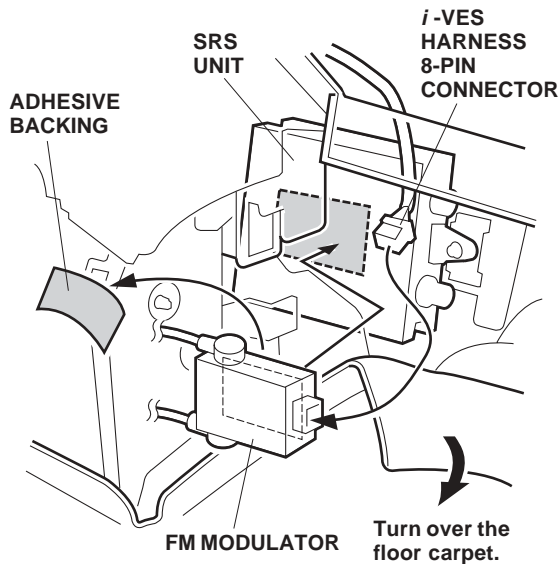

44. Using isopropyl alcohol on a shop towel, thoroughly clean the area where the FM modulator will attach. Remove the adhesive backing from the cushion on the FM modulator, and attach the FM modulator to the SRS unit.
45. Route the FM modulator antenna leads to the audio unit opening, and secure the FM modulator antenna lead to the vehicle harness with one wire tie.

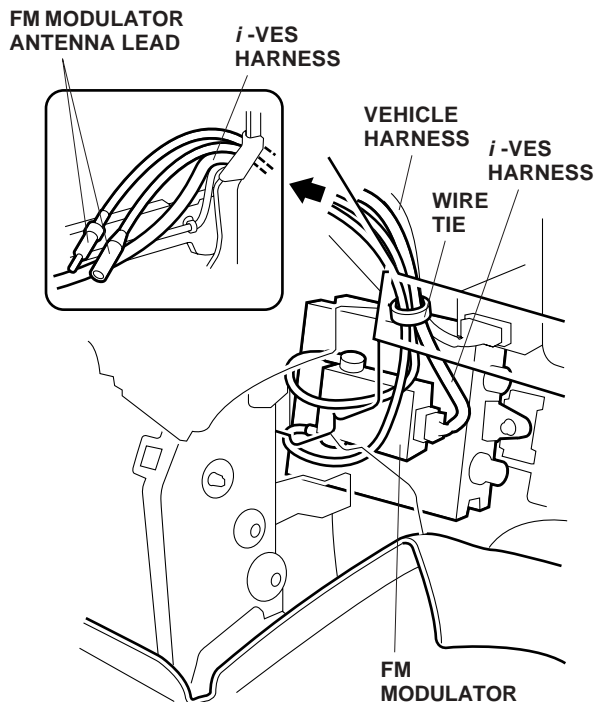

46. Plug the vehicle antenna lead into the FM modulator antenna lead.

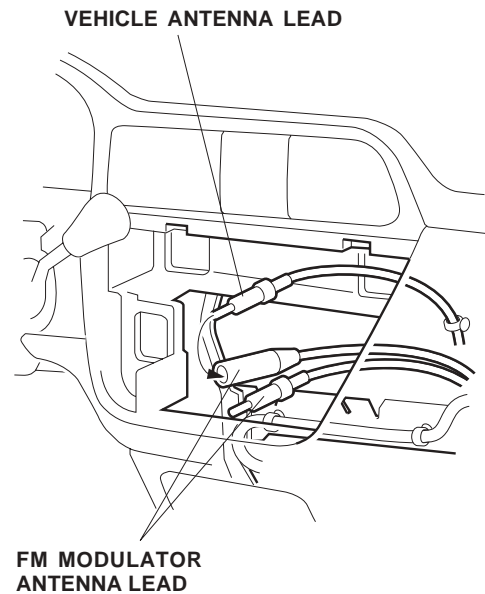

Installing the DVD Player

If you're installing the DVD player into the beverage holder opening, continue with step 46, otherwise; go to step 51.

46. From the back of the DVD player, slide the bezel onto the DVD player.

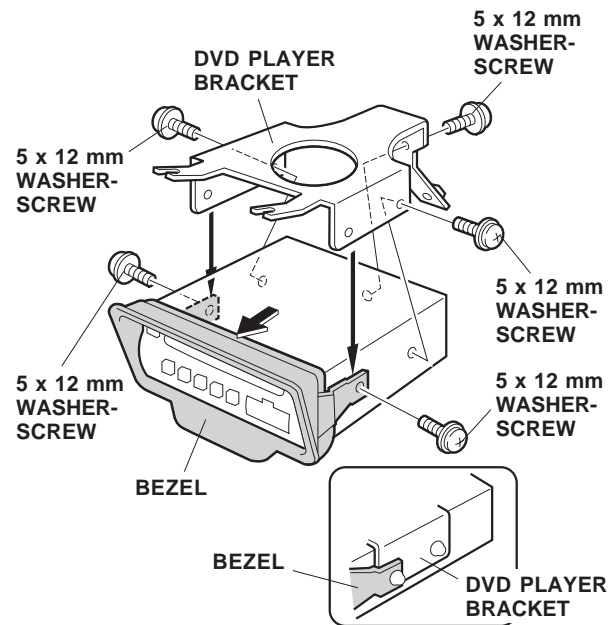

47. Attach the DVD player bracket to the DVD player, and install the DVD player bracket with bezel to the player using the five 5 x 12 mm washer-screws.

48. Plug the *i*-VES harness 20-pin and 16-pin connectors into the rear of the DVD player.

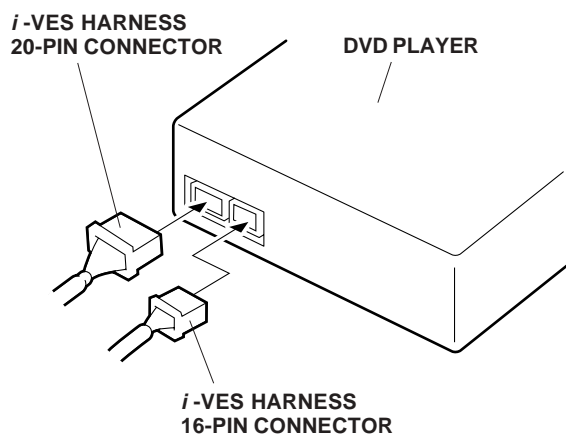

49. Slide the DVD player into the beverage holder opening, and install the three self-tapping screws and two screws you removed in step 13, along with the two 5 mm flange nuts provided. Do not pinch the vehicle harness between the DVD player bracket and the vehicle frame.

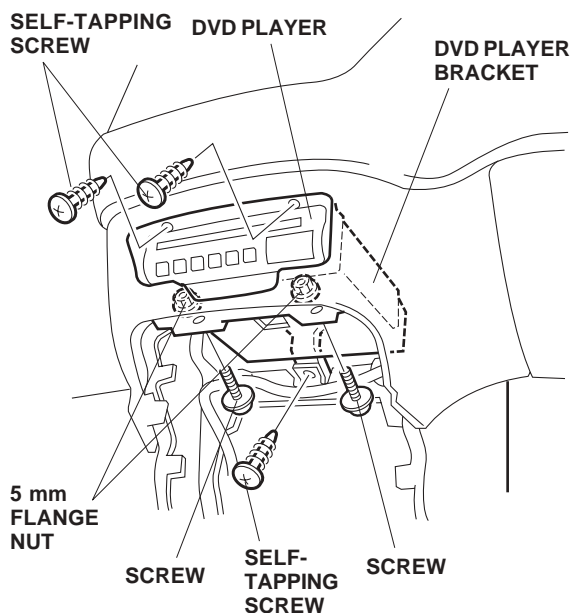

50. Plug the *i*-VES harness 20-pin connector and the FM modulator antenna lead into the rear of the audio unit. (If equipped with a navigation system, plug the *i*-VES harness 20-pin connector, the vehicle connectors, and the antenna lead into the rear of the navigation unit.) Slide the audio unit or navigation unit into the audio unit opening, and install the four bolts and the two self-tapping screws, if equipped.

Without Navigation System:

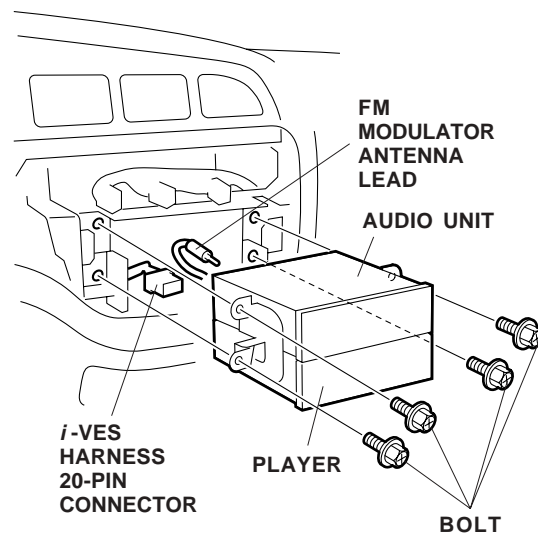

With Navigation System:

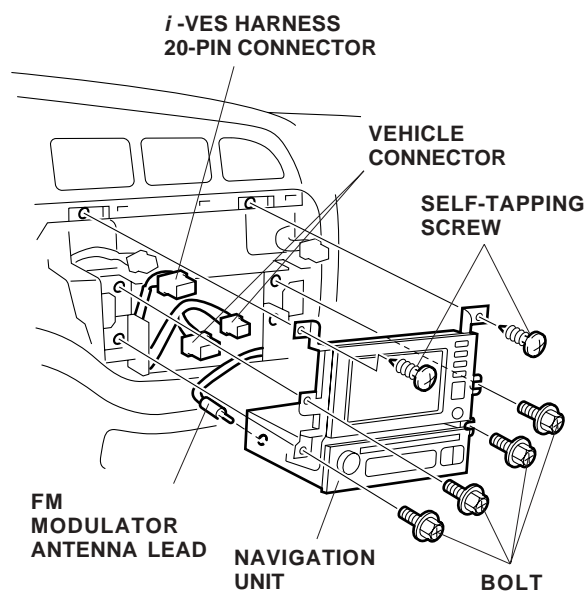

If you're installing the DVD Player in the audio unit opening, continue with step 51, otherwise; go to step 56.

51. Remove the left and right audio unit brackets (two washer-screws for each bracket).

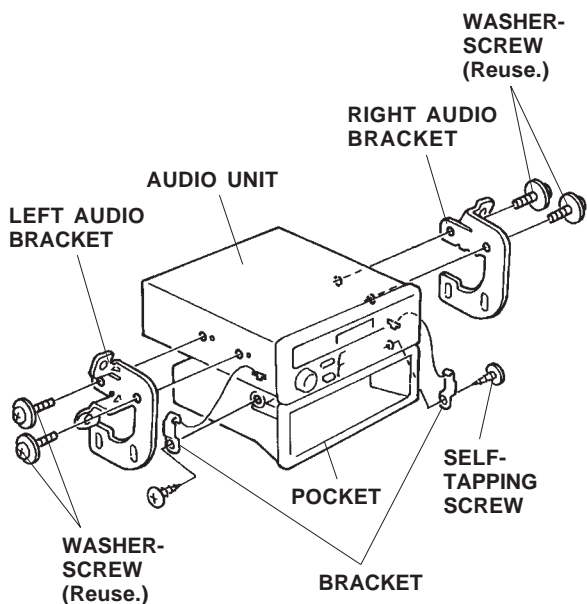

52. Remove the pocket (two self-tapping screws), then separate the audio unit from the pocket. Set the pocket aside; it will not be reused.
53. Position the audio unit on the DVD player, and reinstall the left and right audio unit brackets with the four washer-screws removed in step 51 and the four 5 x 12 mm washer-screws from the *i*-VES base unit kit.

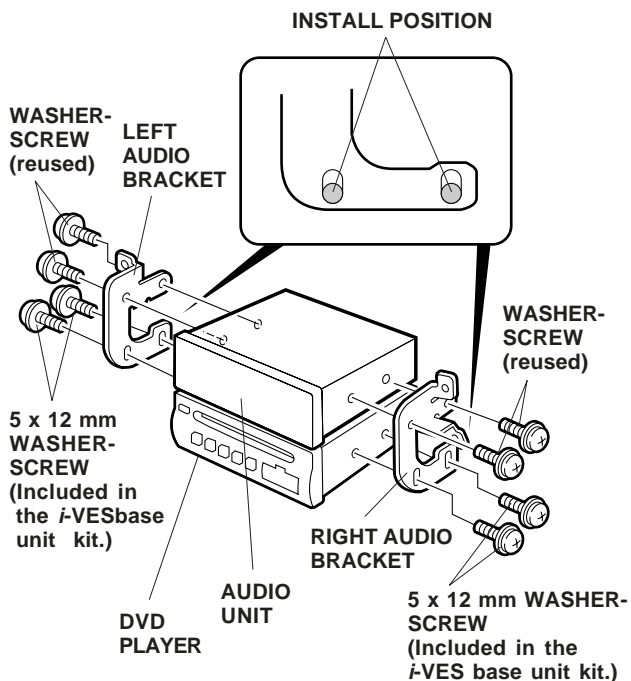

54. Plug the *i*-VES harness 20-pin and 16-pin connectors into the rear of the DVD player, and plug the *i*-VES harness 20-pin connector (blue) into the rear of the audio unit.

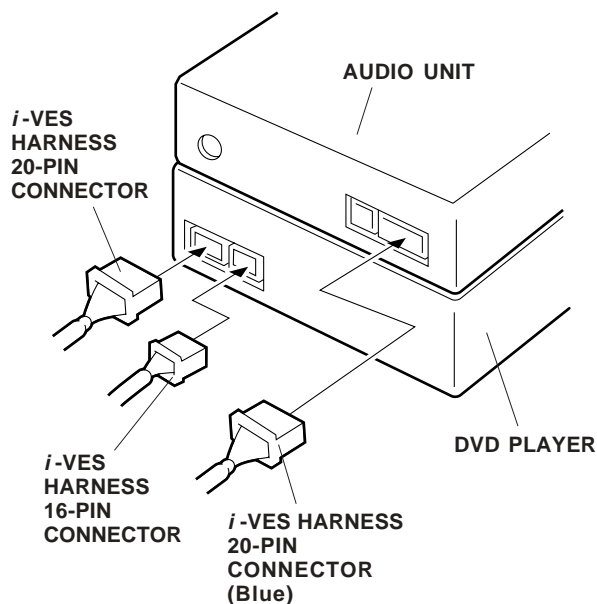

55. Slide the audio unit and DVD player into the audio unit opening, and install the four bolts.

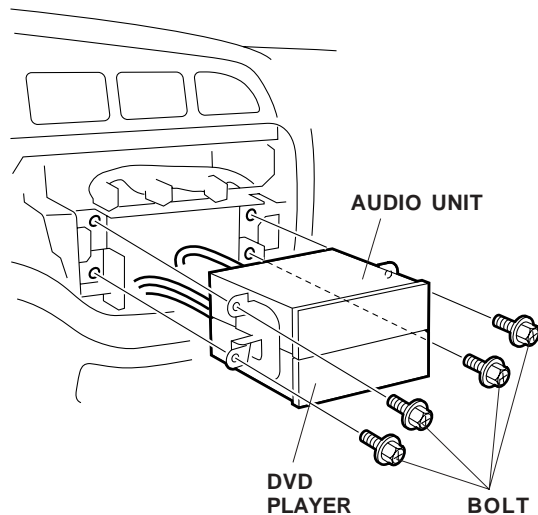

56. Check that all wire harnesses are routed properly and all connectors are plugged in.
57. Reconnect the negative cable to the battery.
58. Enter the customer's radio anti-theft code, and reset the radio station presets.
59. Set the clock.
60. Check the operation of the monitor console and DVD player according to the Owner's Manual provided.
61. Put the *i*-VES Owner's Manual in the glove box.
62. Reinstall all removed parts. Torque the seat belt anchor bolts to 32 N·m (24 lb·ft).

NOTE: Whenever the battery is disconnected, the driver's window AUTO function is disabled.

63. Start the engine. Push down on the driver's window switch until the window is fully open.
64. Pull up on the driver's window switch to close the window completely, then hold the switch for 2 seconds.
65. Test the AUTO window function.