



# INSTALLATION INSTRUCTIONS

Accessory	Application	Publications No.
<b>CD CHANGER ATTACHMENT KIT</b>	<b>ODYSSEY</b>	<b>All 22030</b>
		Issue Date <b>AUG 2000</b>

## PARTS LIST

### CD Changer Attachment Kit: P/N 08B12-S0X-100

Right side rail bracket

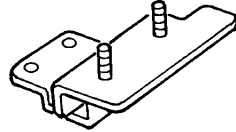

Left side rail bracket

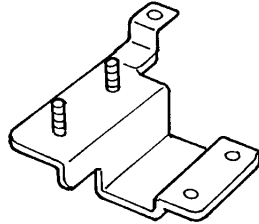

BUS Cable

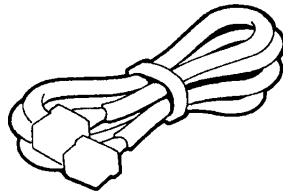

4 Flange bolts, 6 x 12 mm



4 Flange nuts, 6 mm



2 Cushion tapes

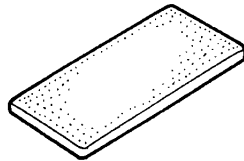

5 Wire ties

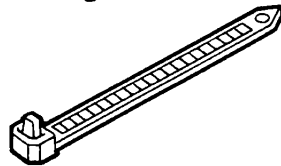

4 Washer-screws, 4 x 8 mm



2 Wire clips

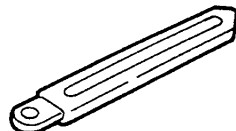

Long wire tie with clip

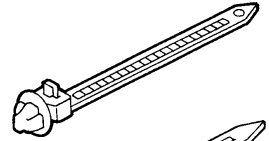

Short wire tie with clip

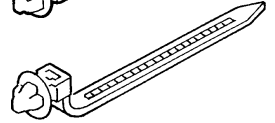

Right CD changer bracket

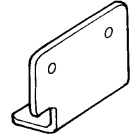

Left CD changer bracket

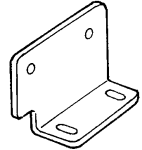

### CD Changer: P/N 08A26-1B1-100

CD changer

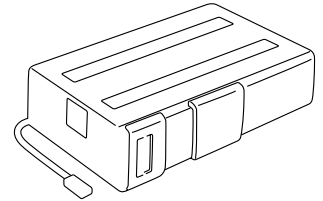

Owner's Manual

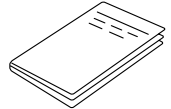

CD magazine

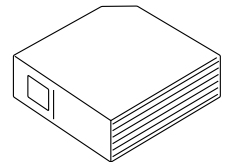

4 Washer-screws, 4 x 6 mm  
(Not used)



Adhesive seal sheet

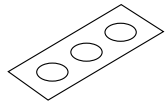

Locking covers

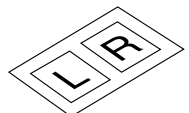

## TOOLS AND SUPPLIES REQUIRED

#2 Phillips screwdriver  
Flat-tip screwdriver  
Stubby Phillips screwdriver  
8 mm, 10 mm, and 14 mm Combination wrenches  
8 mm, 10 mm, and 14 mm Sockets  
Tape measure  
Ratchet  
Torque wrench  
Shop towel  
Diagonal cutters

### Illustration of the CD Changer Installed on the Vehicle

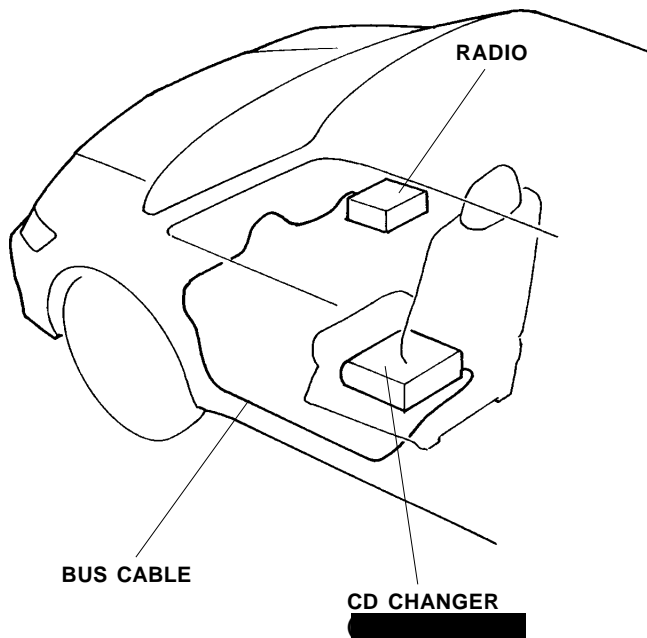

## INSTALLATION

**Customer Information:** The information in this installation instruction is intended for use only by skilled technicians who have the proper tools, equipment, and training to correctly and safely add equipment to your vehicle. These procedures should not be attempted by "do-it-yourselfers."

1. If equipped, make sure you have the anti-theft code for the radio, then write down the frequencies for the preset buttons.
2. Disconnect the negative cable from the battery.

3. Remove the console panel:
  - Move the gear selector to the 1 position.

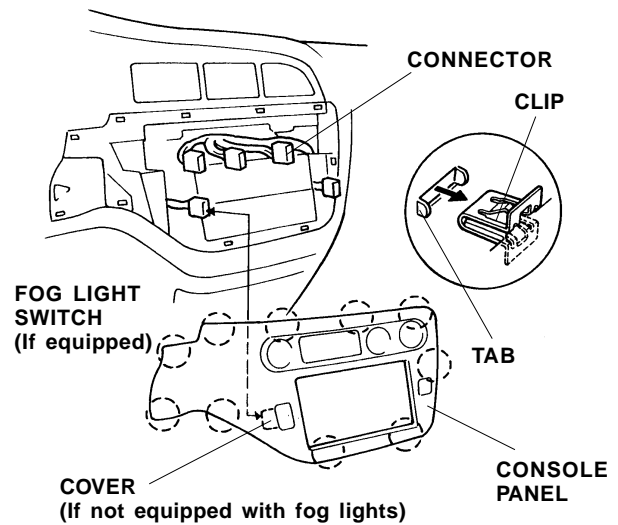

- Using a small flat-tip screwdriver around a shop towel, gently pry out and remove the cover. If the vehicle is equipped with optional fog lights, remove and unplug the fog light switch.
  - Reach inside the cover hole, gently pull along the bottom to release the lower clips, and work toward the top to release all ten clips.
  - Pull out the console panel, unplug the connectors and remove the panel.
4. Remove the radio (four bolts, unplug the radio connector, and the antenna lead).

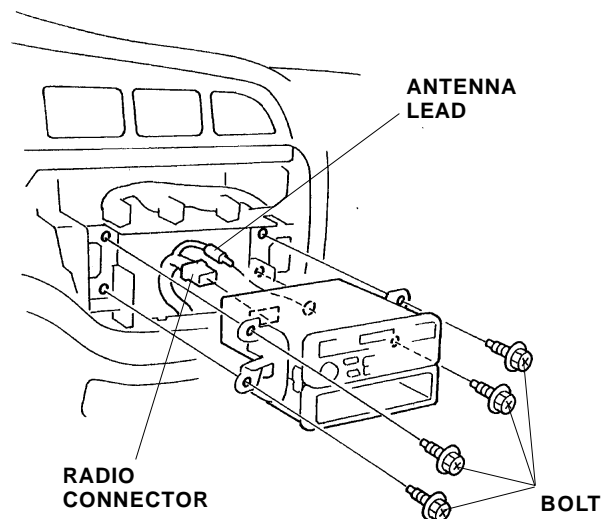

- Remove the fuel lid opener lever.

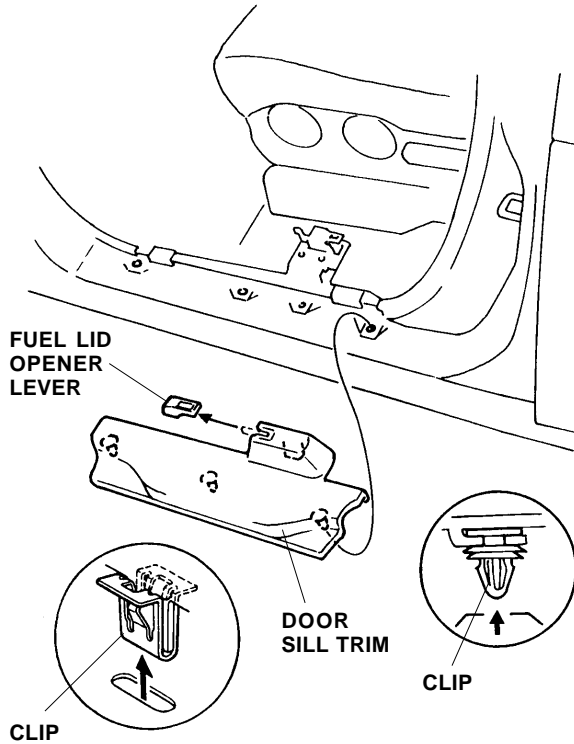

- Pry up on the clips, and remove the front left door sill trim. Be careful not to damage the clips.
- Pull up the driver's side front door opening trim, and unscrew the clip securing the kick panel. Remove the kick panel by pulling it out toward you.

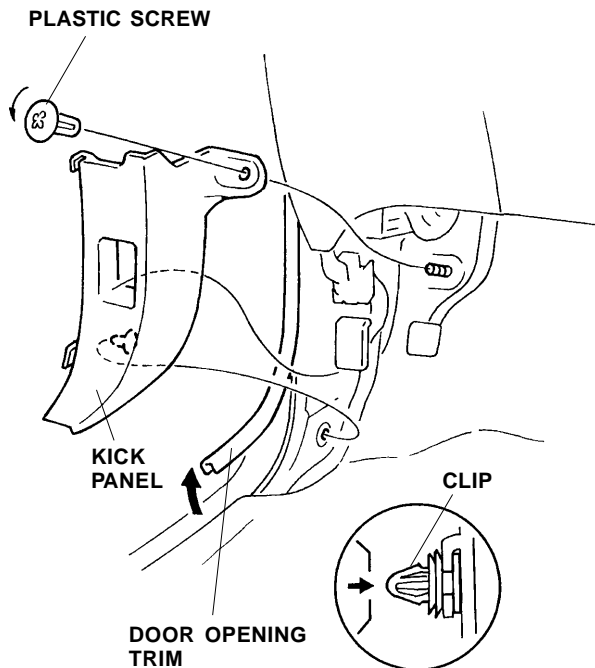

- Remove the driver's dashboard lower cover (one self-tapping screw and three clips). On an EX model, unplug the climate control 2-pin connector from the sensor.

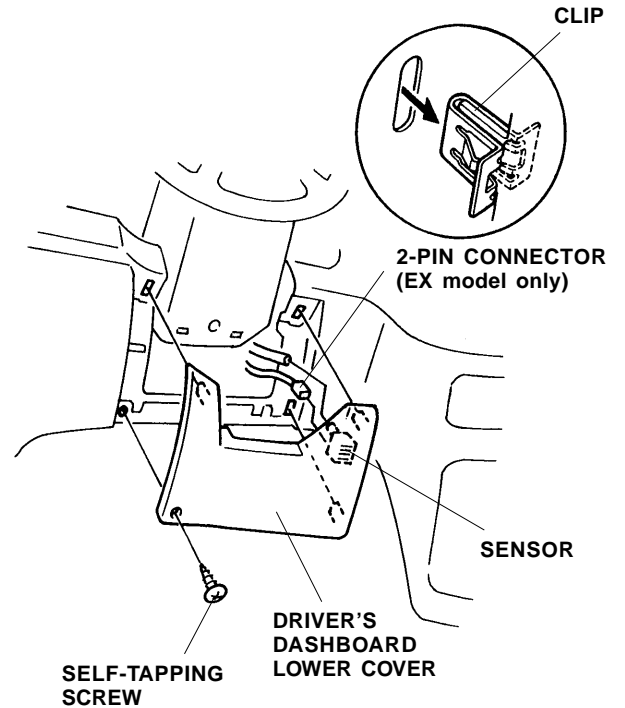

- Remove the driver's seat inside seat rail covers.

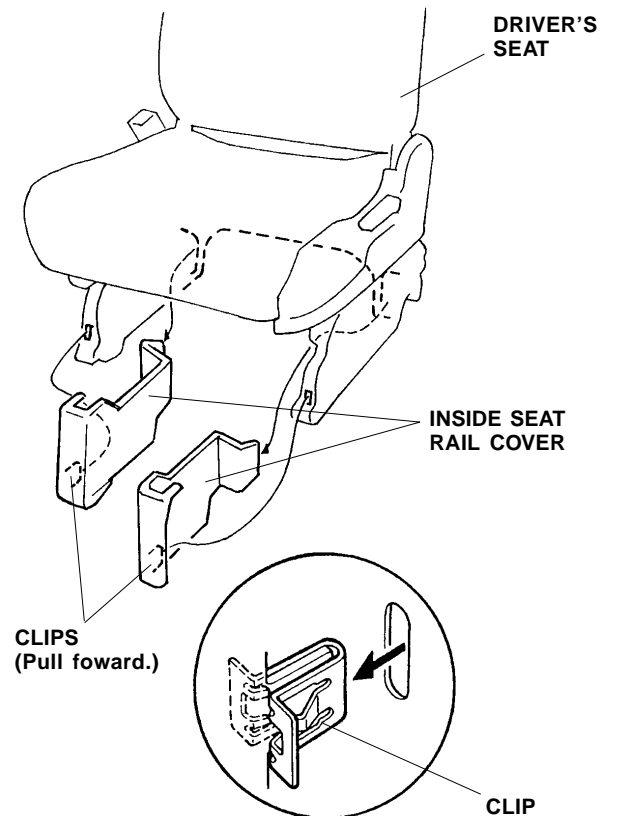

10. Remove the rear seat rail cover from the driver's seat by pulling to release the three clips.

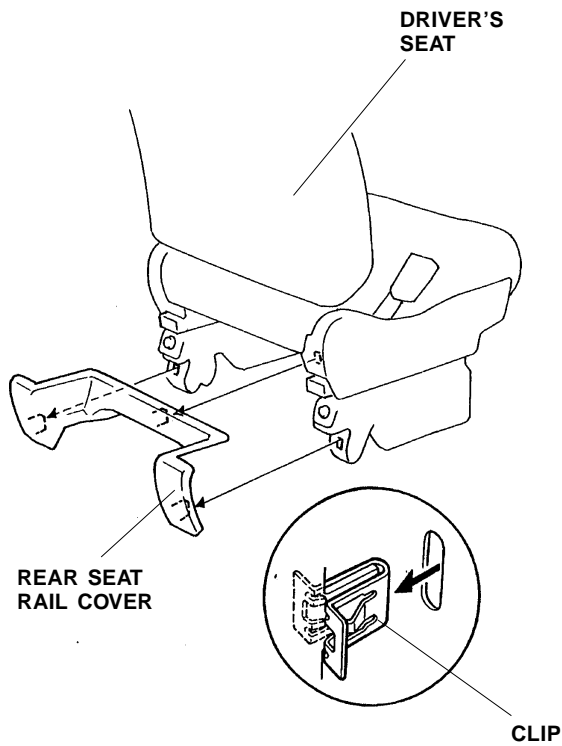

11. Remove the four bolts securing the driver's seat side rails to the floor. Disconnect the connector under the seat, and remove the seat.

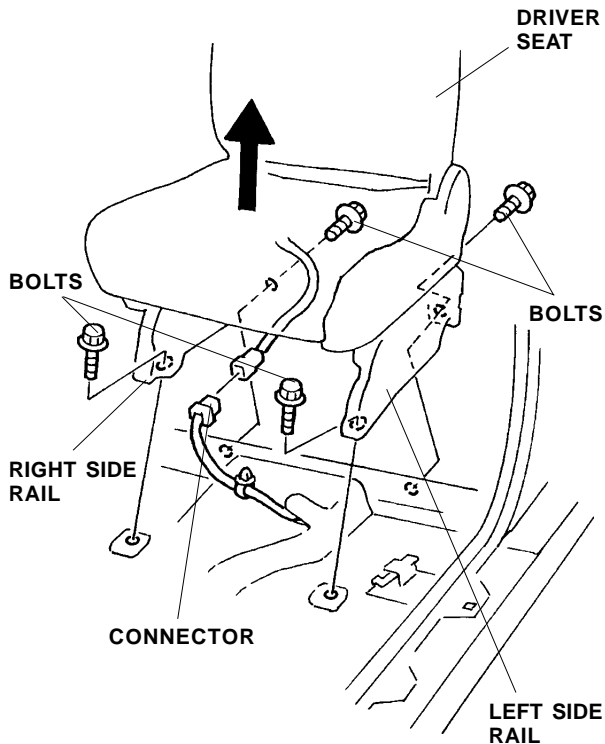

### Installing the Seat Rail Brackets

12. Position the left side rail bracket on the driver's seat left side rail, and align the two holes in the bracket with the two inside holes in the side rail. Attach the bracket with two 6 x 12 mm flange bolts. Repeat to install the right side rail bracket.

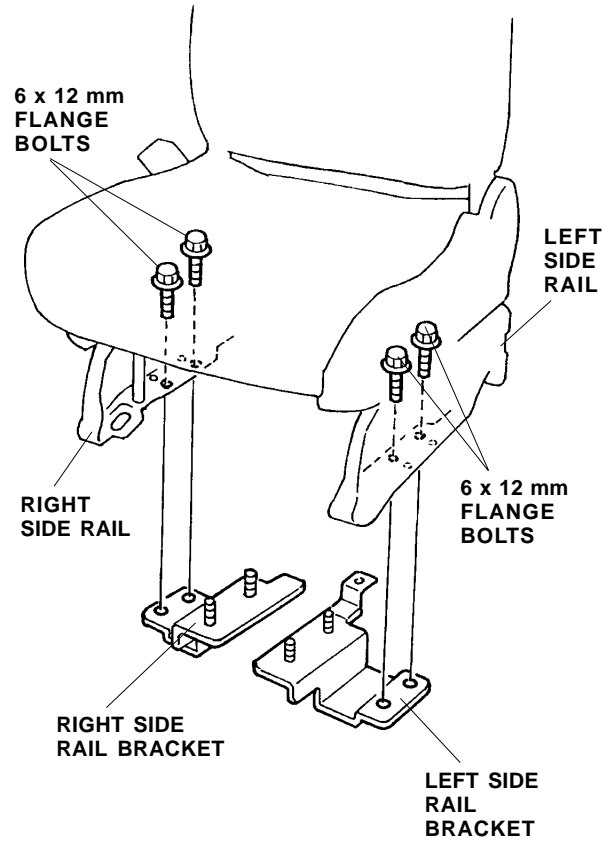

## Routing the BUS Cable

- Turn over the floor carpet. Route one end of the BUS cable under the floor carpet and out through the cutout in the carpet.

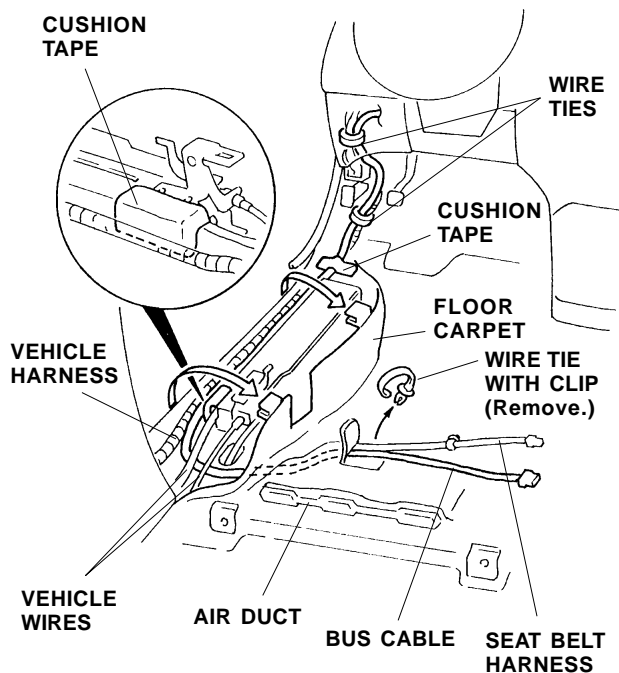

- Using diagonal cutters, cut and remove the wire tie with clip from the seat belt harness to free the harness from the air duct.
- Route the other end of the BUS cable forward alongside the vehicle harness. The BUS cable should be the same length as the seat belt harness.
- Wrap one cushion tape around the edge of the fuel lid opener to protect the BUS cable. Secure the BUS cable to the floor and to the vehicle harness with the other cushion tape and two wire ties in the areas shown.

- Continue routing the BUS cable over the pipe stays and the steering column and out through the radio opening.

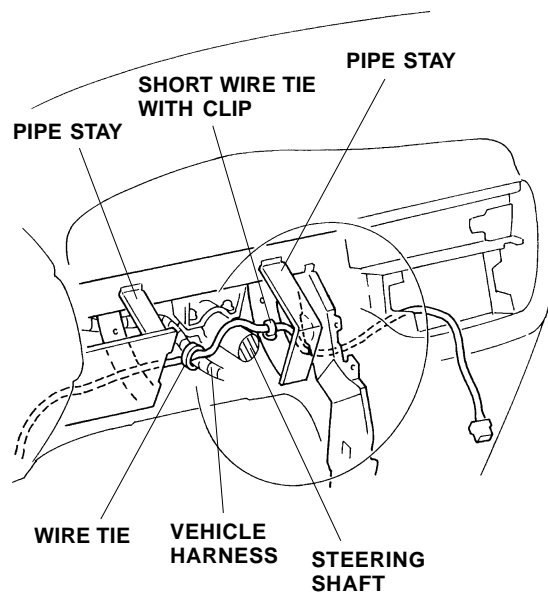

- Secure the BUS cable to the vehicle harness with one wire tie. Secure the BUS cable to the pipe stay with the short wire tie with clip. Secure the BUS cable only as shown and not to the yellow SRS harness.
- Bundle up the excess length and secure the BUS cable to the center dashboard stay with one wire tie.

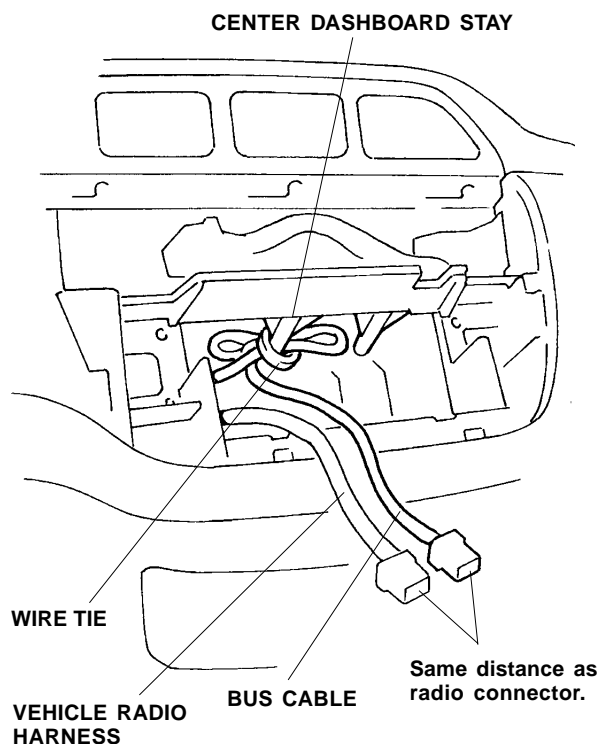

20. Plug in the radio connector, the antenna lead and the BUS cable; then reinstall the radio.

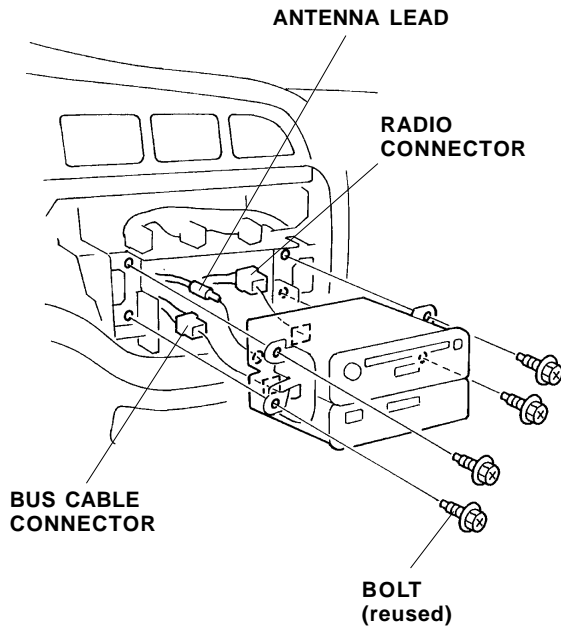

**With Pocket:**

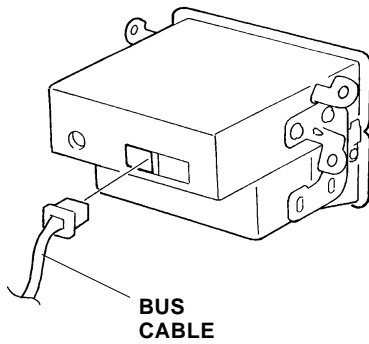

**With Cassette Player:**

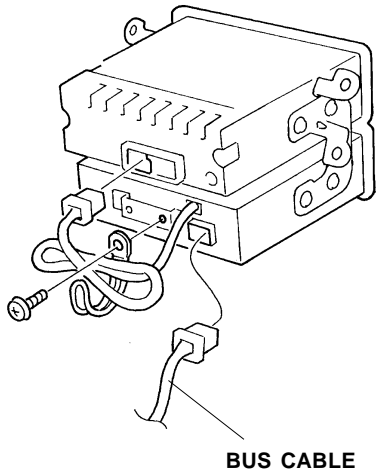

**Installing the CD Changer**

21. Carefully unpack the CD changer. Remove the three shipping clips, and discard the shipping cover. Save the shipping clips for your customer in the event the unit needs to be serviced.

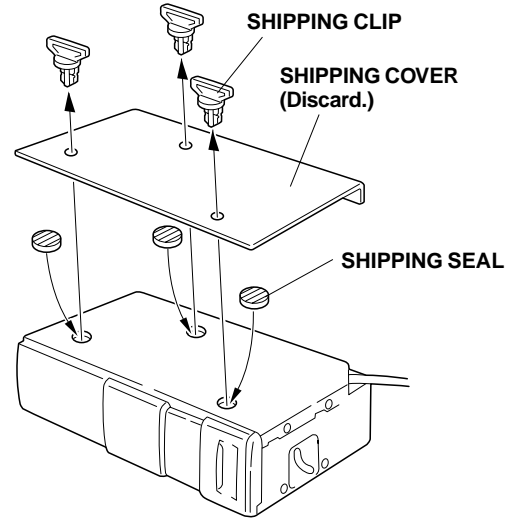

22. Visually check the position of the spring adjusting pin on both sides of the CD changer. If the spring adjusting pins are not in the horizontal (H) position, move the pins to the horizontal (H) position by sliding them up with an awl.

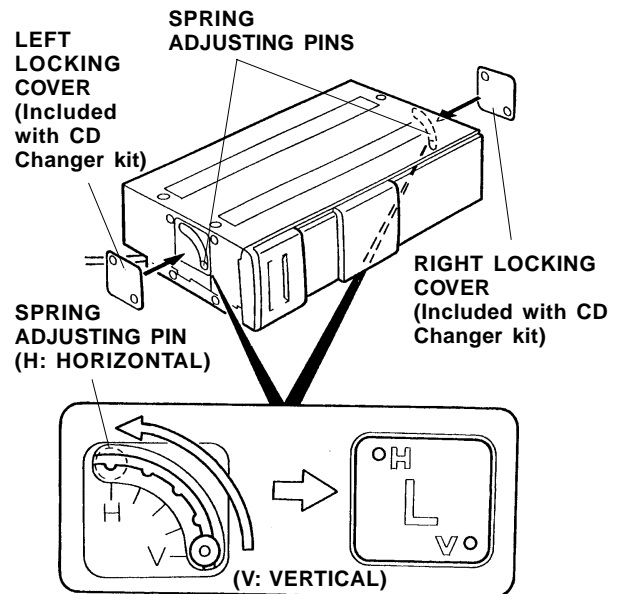

24. Remove the adhesive backing from the "L" and "R" locking covers, and attach them to the sides of the CD changer. Align the diagonally opposite holes with the H and V positions.

25. Install the right CD changer bracket on the CD changer using two 4 x 8 mm washer-screws through the holes in the two wire clips. Install the left CD changer bracket on the CD changer using two 4 x 8 mm washer-screws.

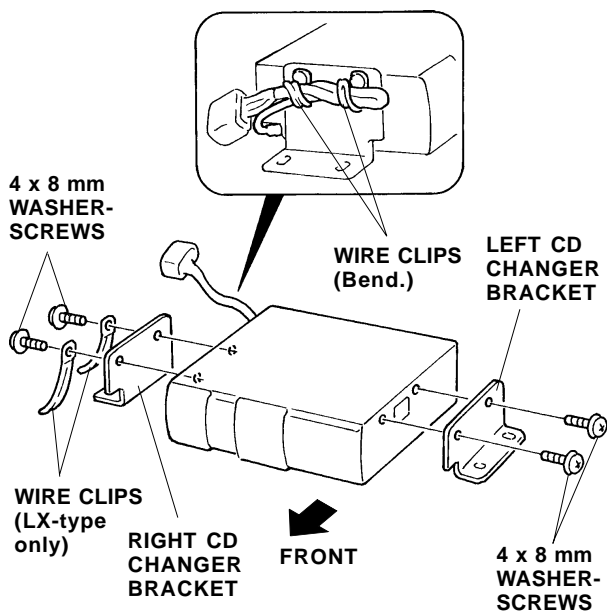

26. Bundle the excess BUS cable, and secure it to the CD changer with the two wire clips.
27. Place the CD changer on the side rail brackets, and install the four 6 mm flange nuts. Tighten the nuts securely.

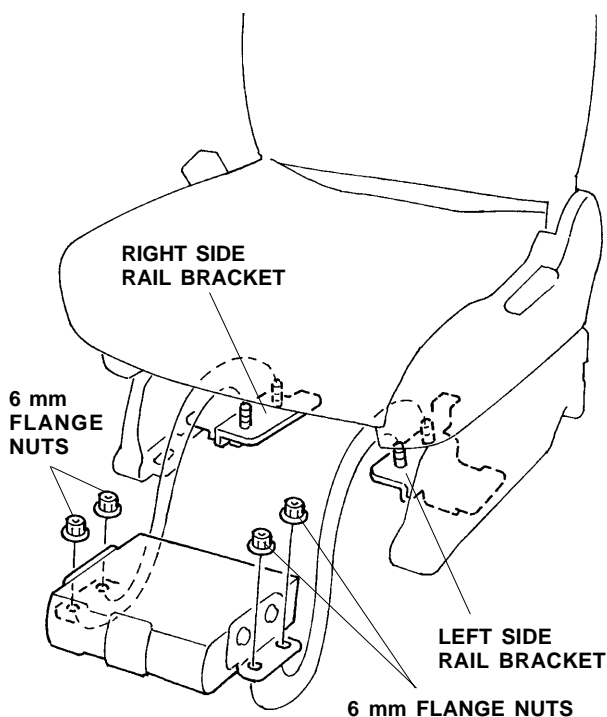

28. Reinstall the driver's seat:

- Reconnect the seat belt harness connector to the bottom of the seat. Secure the BUS cable to the CD changer bracket with the long wire tie with clip.
- Plug the BUS cable connector into the BUS cable connector from the CD changer.
- Secure the BUS cable to the seat cross bar with one wire tie.
- Torque the seat bolts to 42 to 55 N•m (30 to 40 lb-ft).

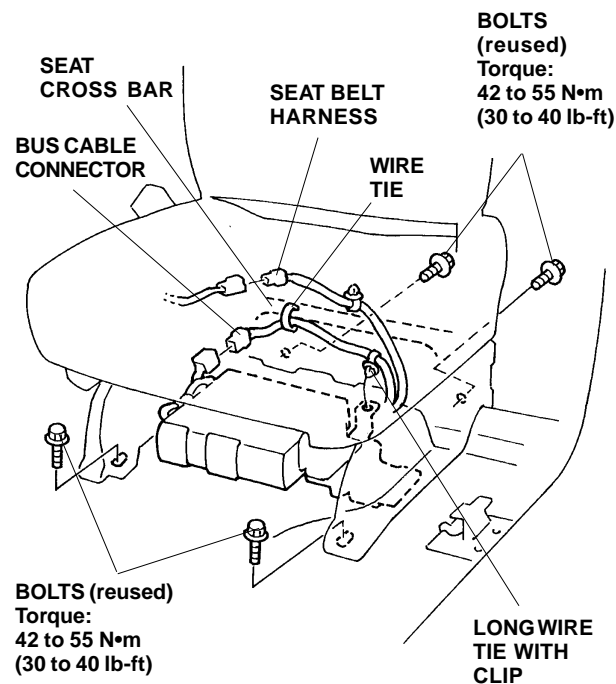

29. Check that all wire harnesses and cables are routed properly and all connectors are plugged in.
30. Reinstall all removed parts.
31. Reconnect the negative cable to the battery.
32. Enter the customer's radio anti-theft code, if applicable, and reset the radio station presets.
33. Reset the clock.
34. Check the operation of the CD Changer according to the Owner's Manual supplied with the unit.
35. Put the CD Changer Owner's Manual and the shipping screws (removed in step 21) in the glove box.