



# INSTALLATION INSTRUCTIONS

Accessory	Application	Publications No.
XM™ SATELLITE RADIO SYSTEM	ODYSSEY	<b>All 33028</b>
		Issue Date <b>AUG 2006</b>

## PARTS LIST

XM Radio Attachment (sold separately):  
P/N 08B15-SHJ-100A

2 Tuner brackets

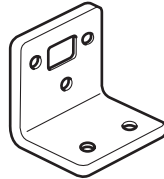

BUS cable

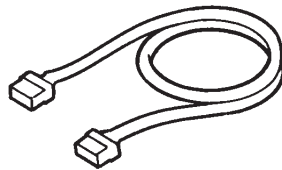

14 Wire ties

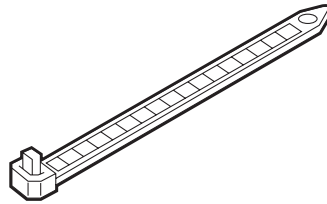

4 Washer-screws, 5 x 8 mm



4 Washer-bolts, 6 x 12 mm



3 EPT seals

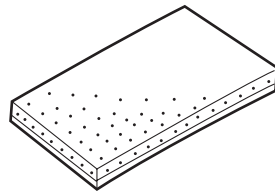

XM Antenna (sold separately):  
P/N: 08A15-0J1-100

Antenna

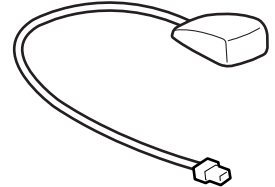

Unit kit (sold separately):  
P/N 08A15-3J1-000

XM Tuner

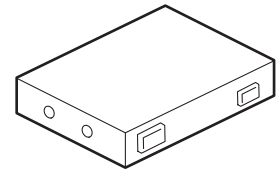

## TOOL AND SUPPLIES REQUIRED

- #2 Phillips screwdriver
- Flat-tip screwdriver
- Tape measure
- Shop towel
- Ratchet
- 8 mm, 10 mm Socket
- Isopropyl alcohol

**Illustration of the XM Radio System Installed on the Vehicle**

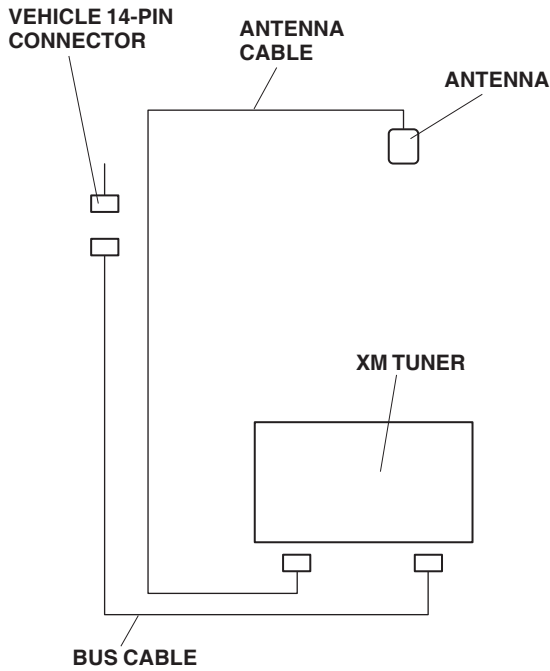
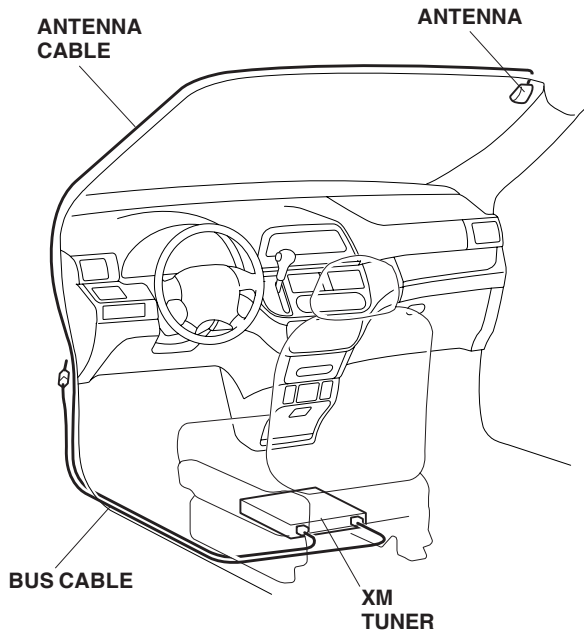

**INSTALLATION**

**Customer Information:** The information in this installation instruction is intended for use only by skilled technicians who have the proper tools, equipment, and training to correctly and safely add equipment to your vehicle. These procedures should not be attempted by “do-it-yourselfers.”

1. Make sure you have the anti-theft code for the radio, then write down the radio station presets.
2. Disconnect the negative cable from the battery.
3. Open the sunglasses holder, remove the two 5 mm bolts. Insert a flat-tip screwdriver between the lens and roof console housing, and gently pry out the map light lens covers. Remove the two ground bolts. Pull out the roof console from the headliner.

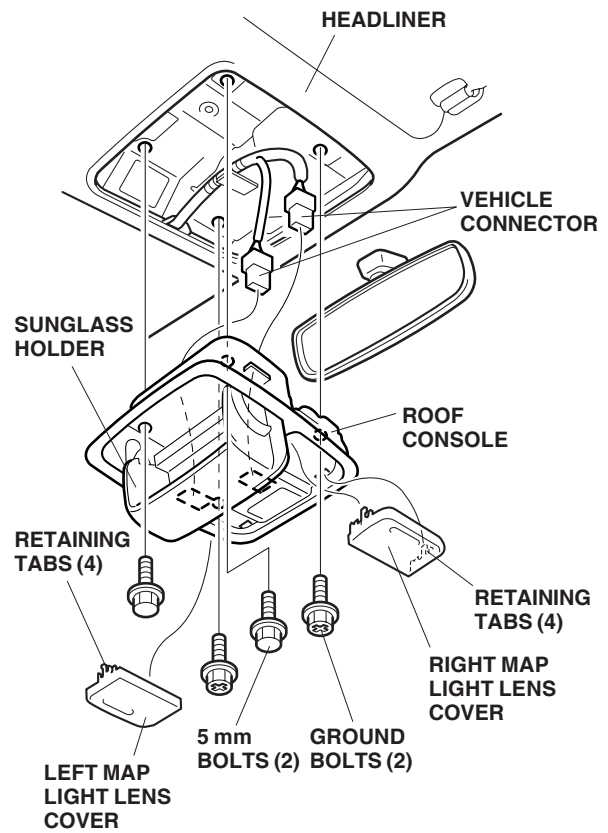

4. Disconnect the two vehicle connectors and remove the roof console.

- Remove the cover from the left sunvisor.

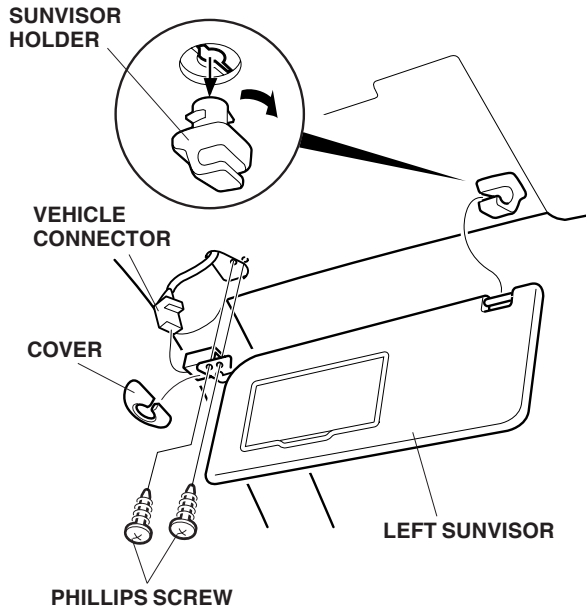

- Remove the two phillips screws, pull out the left sunvisor, disconnect the vehicle connector, and remove the left sunvisor.
- Repeat steps 5 and 6 to remove the right sunvisor.
- Remove the right and left sunvisor holders. Turn the holders 90°, then pull it out.
- Remove the door opening trim from around the left front "A" pillar trim. Remove the left front "A" pillar (two clips).

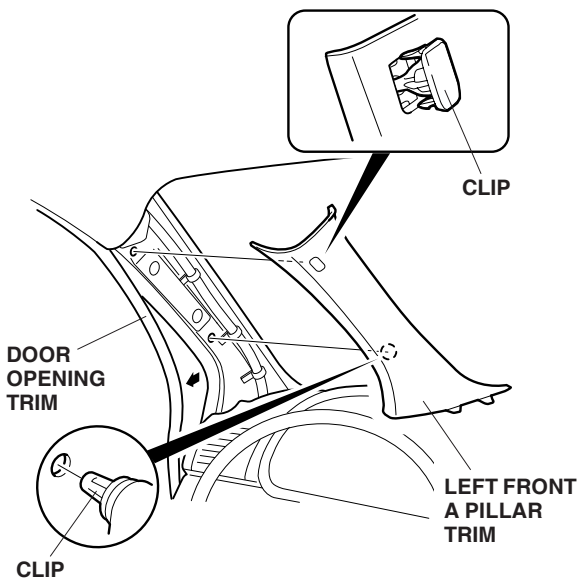

- Remove the driver's side instrument panel (six clips and three retaining tabs).

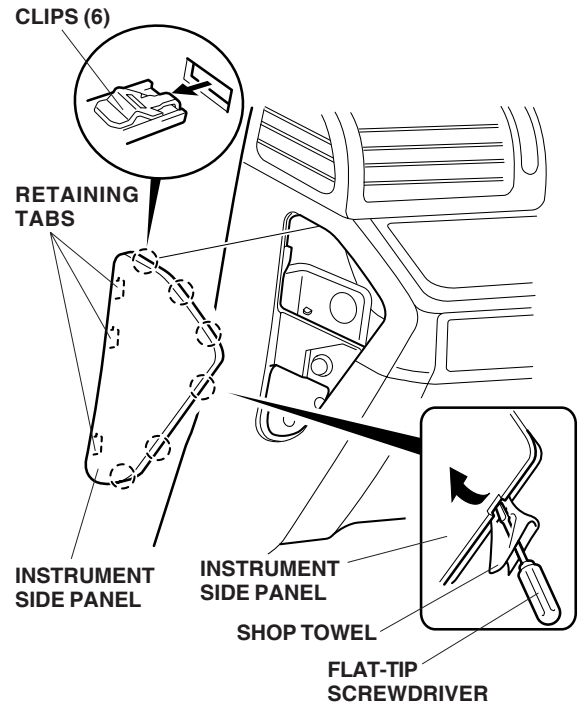

- Remove the left front door sill trim (three clips).

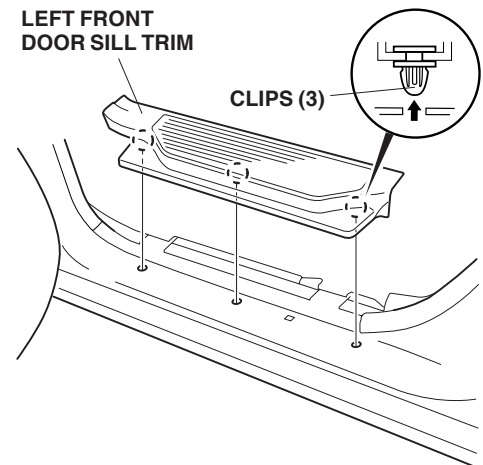

12. Pull out the door opening trim at the left kick panel. Remove the left kick panel (three clips).

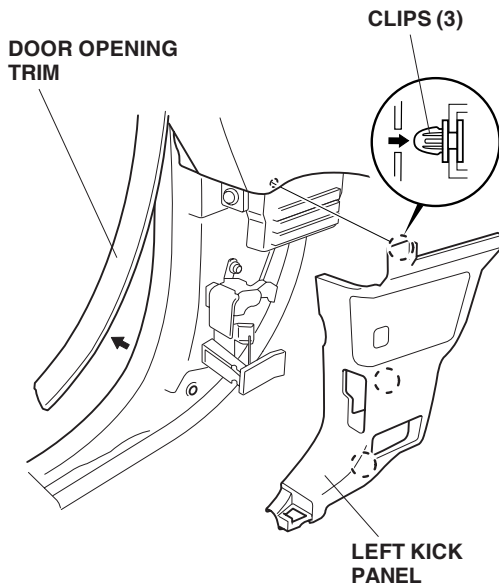

13. Remove the driver's seat rear rail cover (four clips).

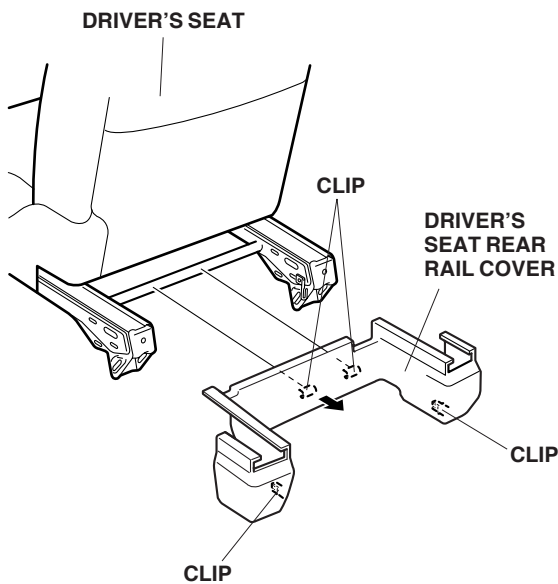

## Installing the Antenna

14. Using scissors, cut three EPT sealers in half. Attach the six pieces of cut EPT sealers around the antenna cable at the locations shown.

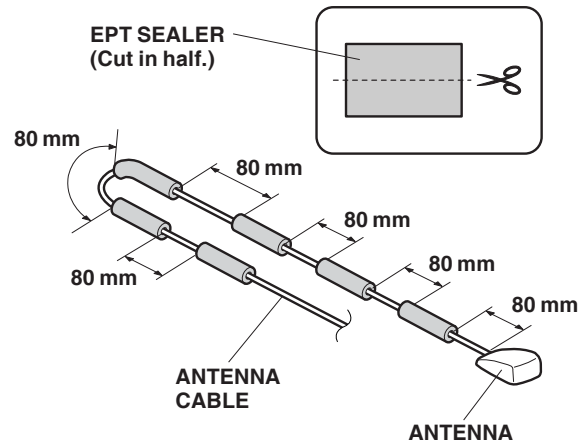

15. Using isopropyl alcohol, clean the areas where the antenna will attach. Remove the adhesive backing from the antenna and attach the antenna to the front window at the locations shown. Install the antenna by applying sufficient pressure.

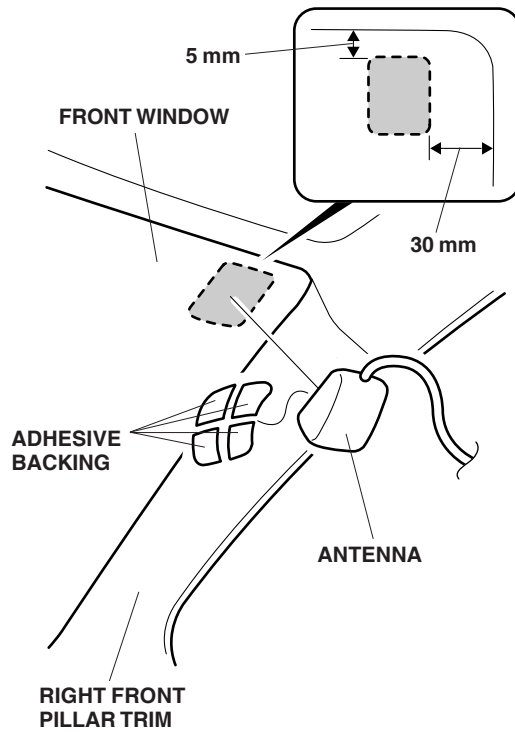

16. Route the antenna cable so that it routes inside the headliner.

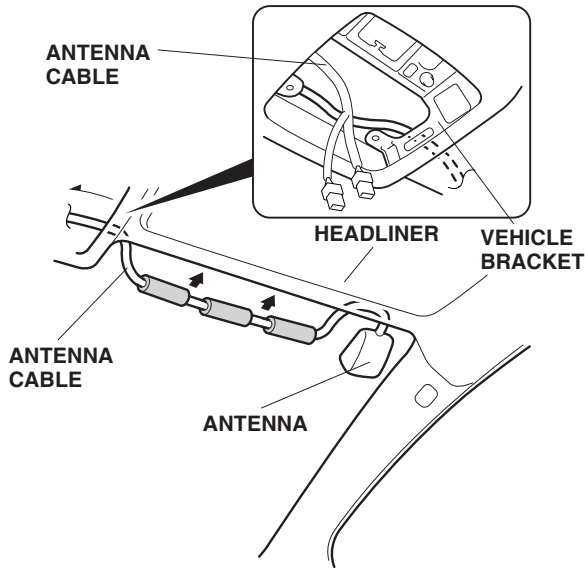

17. Route the antenna cable in the headliner and secure it with wire ties to the vehicle harness.

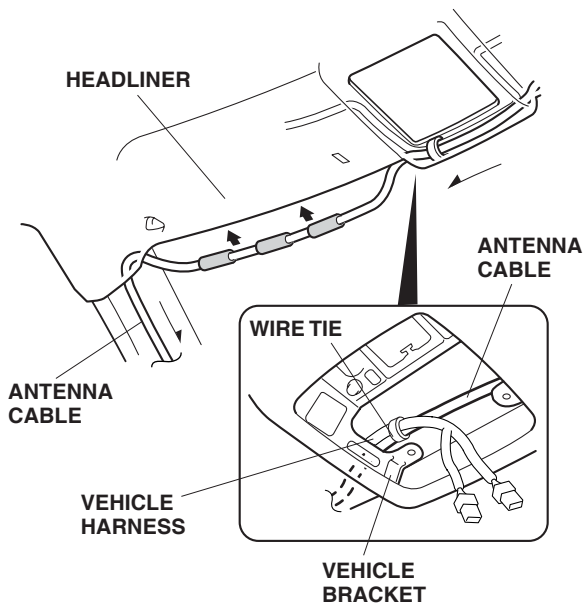

18. Route the antenna cable along the left front "A" pillar. Secure the antenna cable to the vehicle harness with four wire ties.

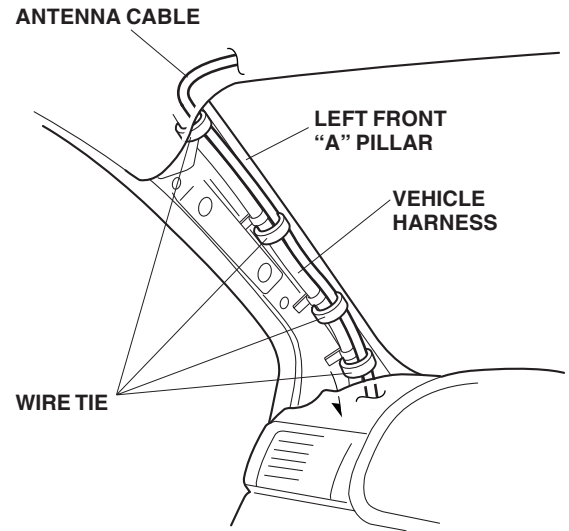

19. Route the antenna cable along the vehicle harness towards the driver's under-dash fuse box. Secure the antenna cable with one wire tie in the area shown.

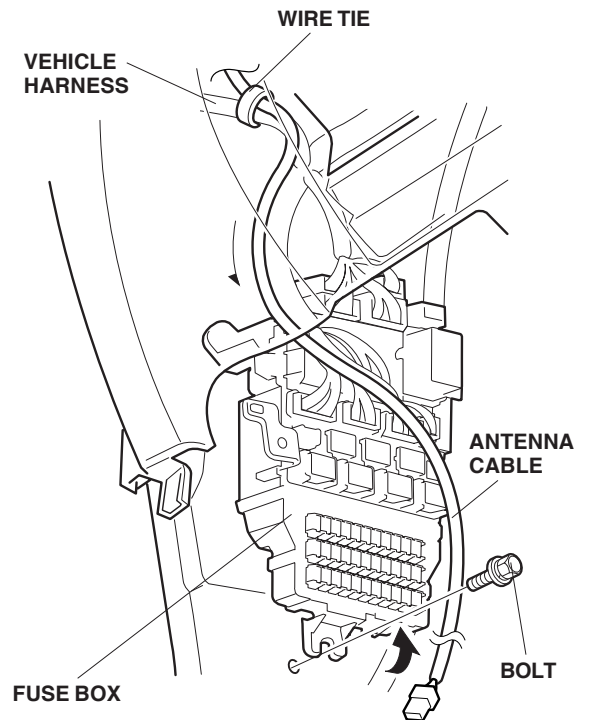

20. Remove the bottom bolt from the driver's under-dash fuse box.

- Turn up the carpet. Route the antenna cable under the carpet and next to the vehicle harness.

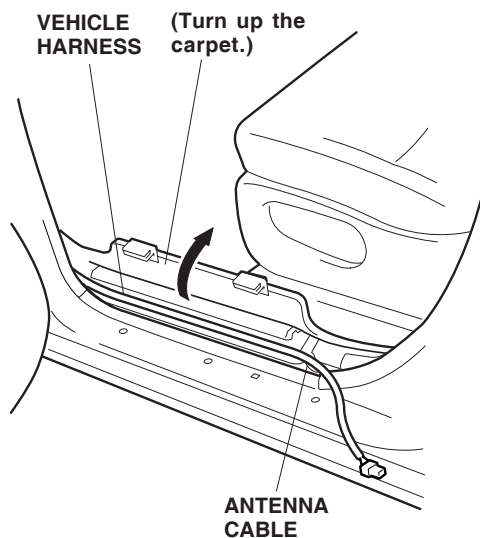

- Turn up the carpet and continue routing the antenna cable underneath the driver seat.

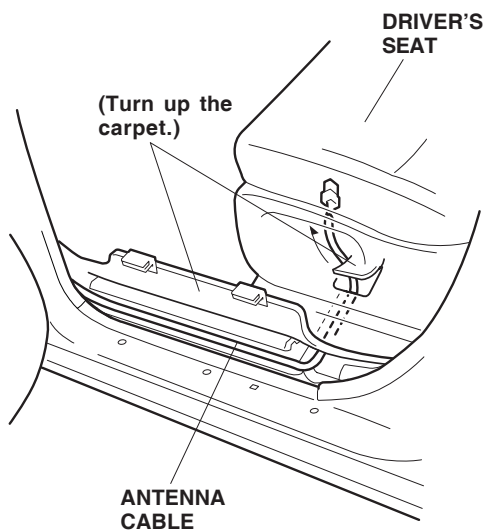

### Routing the BUS Cable

- Under the dash, locate the vehicle 14-pin connector blue-taped to the vehicle harness. Remove the blue-tape to free the connector.

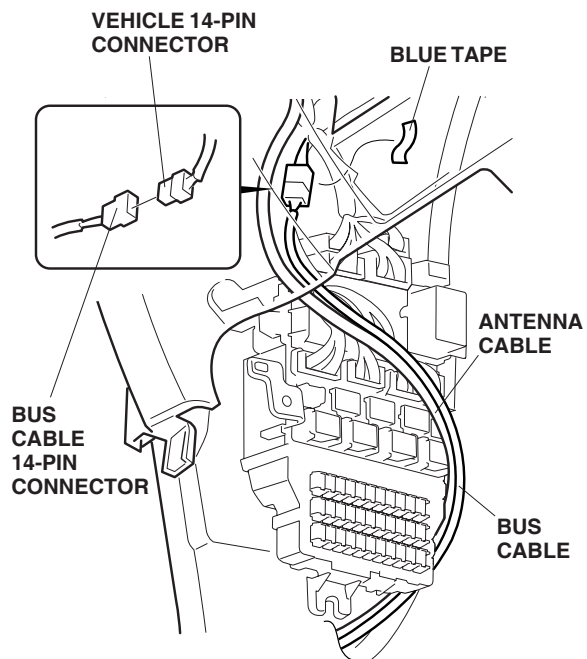

- Plug one end of the BUS cable into the 14-pin connector to the vehicle 14-pin connector you just freed, and route the BUS cable along the antenna cable.

- Route the BUS cable along the antenna cable underneath the driver seat. Secure the antenna cable and BUS cable to the vehicle harness at the carpet opening with one wire tie.

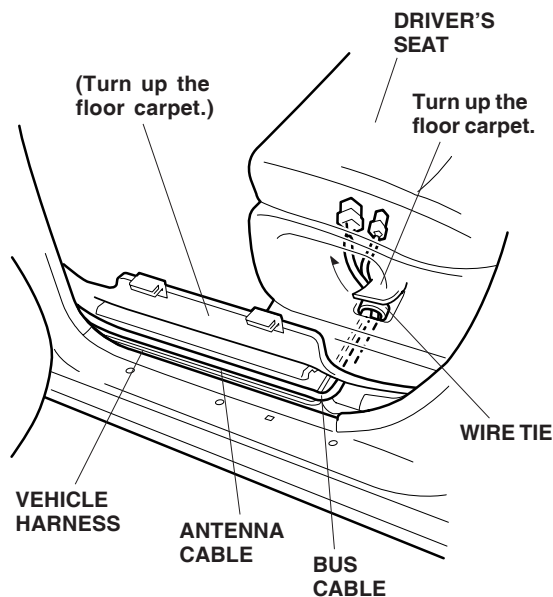

26. Secure the BUS cable and the antenna cable to the vehicle harness with three wire ties in the area shown.

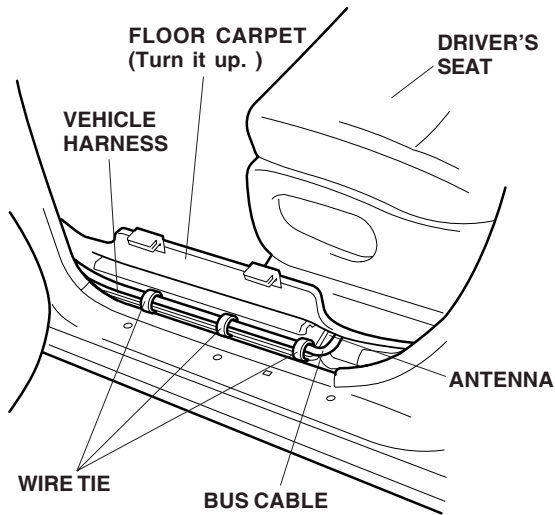

27. Bundle up the excess length of antenna cable, and secure the cable to BUS cable with two wire ties.

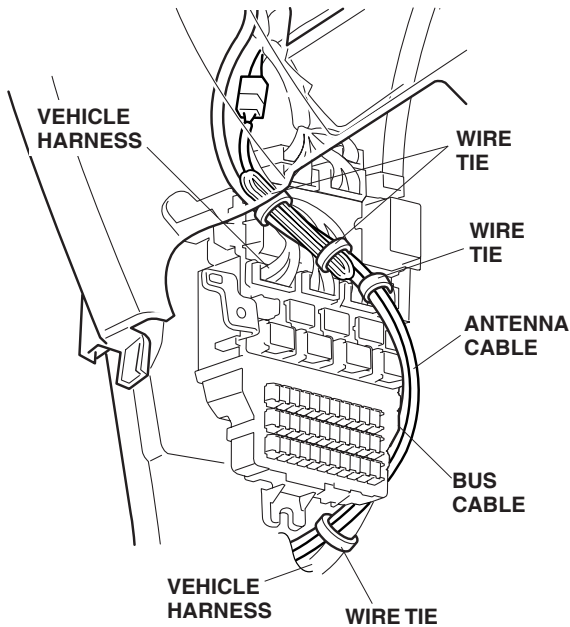

28. Secure the antenna cable and the BUS cable to the vehicle harness with two wire ties, and reinstall the driver's under-dash fuse box bolt.

### Installing the XM Tuner

29. Attach the tuner brackets to the XM tuner with four 5 x 8 mm washer-screws.

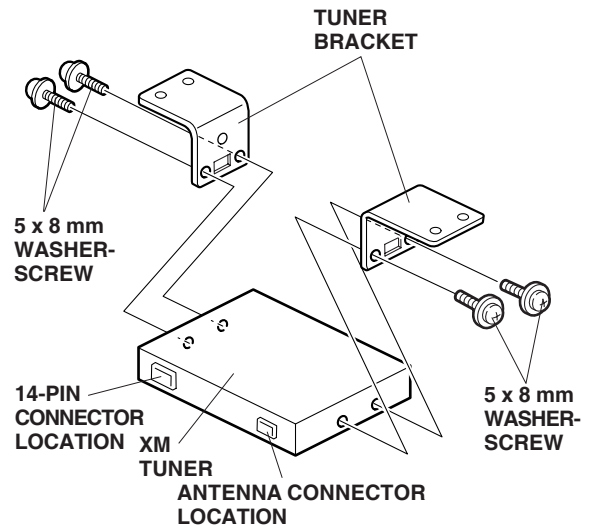

30. Install the XM tuner assembly to the bottom of the driver's seat with four 6 x 12 mm washer-bolts.

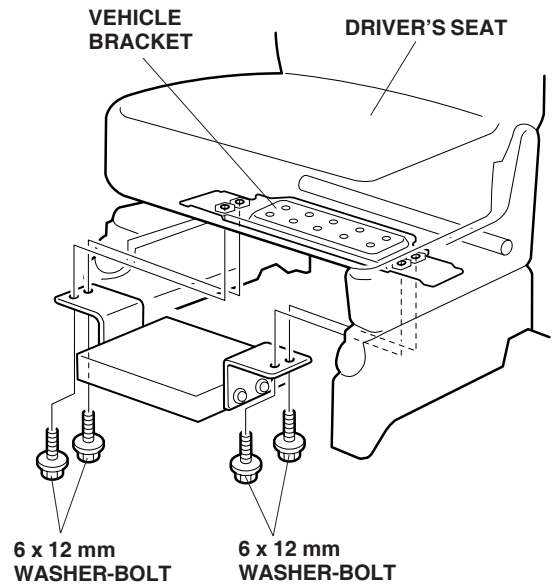

31. Plug the BUS cable 14-pin connector and antenna cable 1-pin connector into the XM tuner.

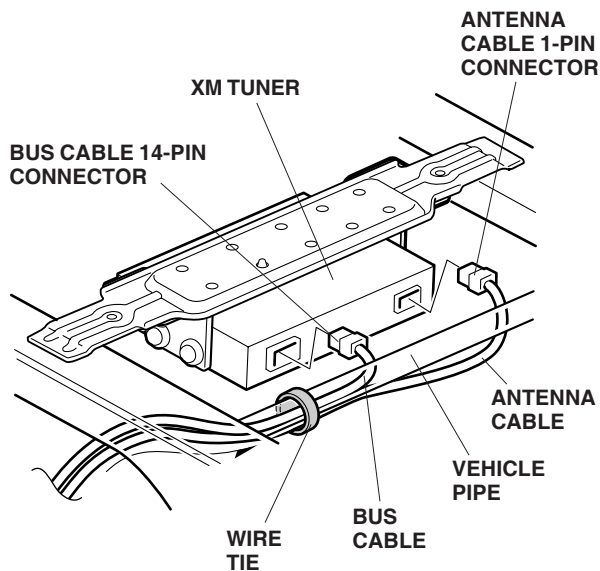

32. Secure the BUS cable and antenna cable to the vehicle pipe with a wire tie.
33. Check that all wire harnesses are routed properly and all connectors are plugged in.
34. Reconnect the negative cable to the battery.
35. Enter the customer's radio anti-theft code, and reset the radio stations.
36. Reset the clock.
37. Reinstall all removed parts.

NOTE: Whenever the battery is disconnected, the driver's AUTO function is disabled.

38. Start the engine. Push down on the driver's window switch until the window is fully open.
39. Pull up on the driver's window switch to close the window completely, then hold the switch for 2 second or more.
40. Test the AUTO window function.