

# INSTALLATION INSTRUCTIONS

Accessory	Application	Publications No.
<b>TRAILER HITCH KIT</b>	<b>2006 PILOT</b>	<b>All 30518</b>
		Issue Date
		<b>NOV 2005</b>

**NOTE: Accessory ATF and power steering coolers are required when installing the trailer hitch.**

## PARTS LIST

**Trailer Hitch Kit:  
P/N 08L92-S9V-101**

Trailer hitch

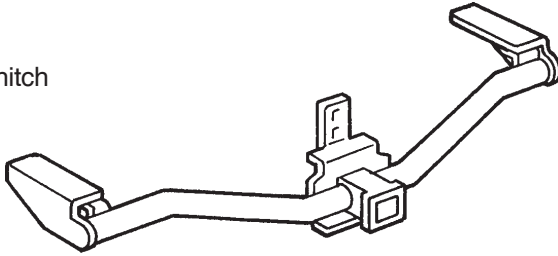

Ball mount

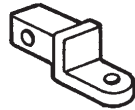

Hitch pin



Hitch pin clip



8 Bolts, 12 x 40 mm



2 Bolts, 10 x 30 mm



2 Bolts, 8 x 20 mm



8 Plain washers, 12 mm



2 Plain washers, 10 mm



2 Plain washers, 8 mm



8 Spring washers, 12 mm



2 Spring washers, 10 mm



2 Spring washers, 8 mm



2 Spacers



Receiver cover

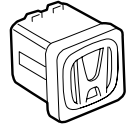

**Harness Kit: (sold separately)  
P/N 08L91-S9V-101**

Trailer hitch harness

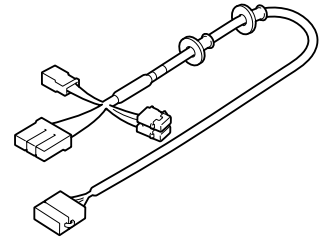

2 Wire ties



2 Connector clips



2 Flange bolts



Flange nut



Harness connector bracket

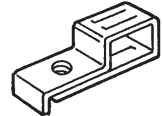

Trailer unit

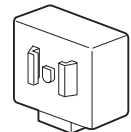

Unit bracket

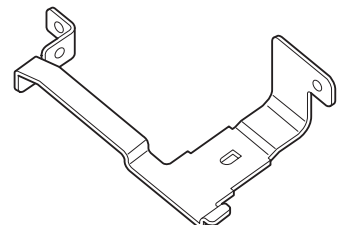

Converter cover

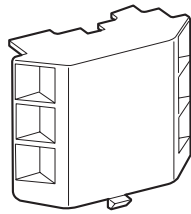

Template

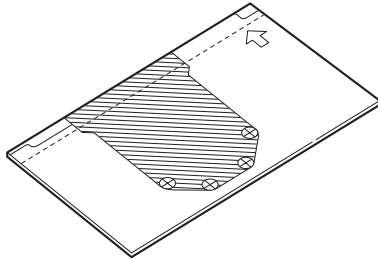

2 Wire ties with clip

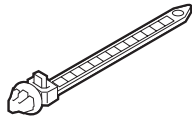

Fuse label



Fuse block (20A)



2 Cushion tapes

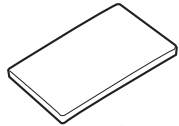

Owner's Manual

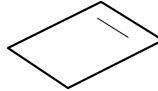

## TOOLS AND SUPPLIES REQUIRED

Flat-tip screwdriver

Diagonal cutters

Ratchet

10 mm Socket

Isopropyl alcohol

Shop towel

Eye protection (safety goggles, face shield, etc.)

Drill

3 mm and 10 mm drill bits

Tape

10 mm Combination wrench

Tape measure

Wheel nut wrench (in vehicle tool kit)

P/N 89211-S3V-A11

Spare tire hoist (if necessary) P/N 74711-S3V-A11

13 mm and 17 mm Sockets

Utility knife

Torque wrench

Pushpin

## INSTALLATION

**Customer Information:** The information in this installation instruction is intended for use only by skilled technicians who have the proper tools, equipment, and training to correctly and safely add equipment to your vehicle. These procedures should not be attempted by "do-it-yourselfers."

### NOTE:

- Accessory ATF and power steering coolers are required when installing the trailer hitch. Have the recommended coolers available.
- Be careful not to damage the rear bumper or other finished surfaces of the body.

### Installing the Converter

1. Make sure you have the anti-theft code for the radio, then write down the radio station presets.
2. Disconnect the negative cable from the battery.
3. Open the tailgate, and remove the cargo floor lid.

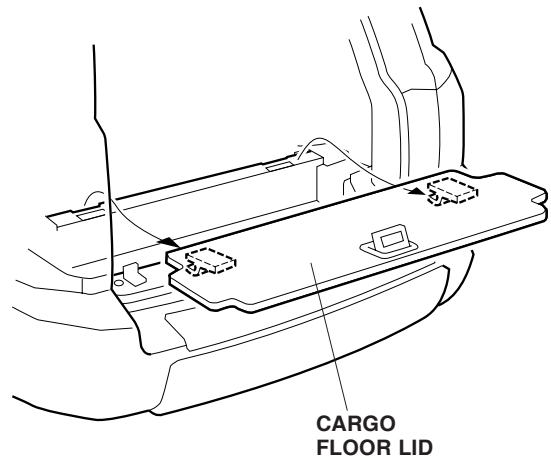

- Remove the tailgate weatherstrip in the area shown. Remove the rear panel trim (lift up to release the four clips and six retaining tabs).

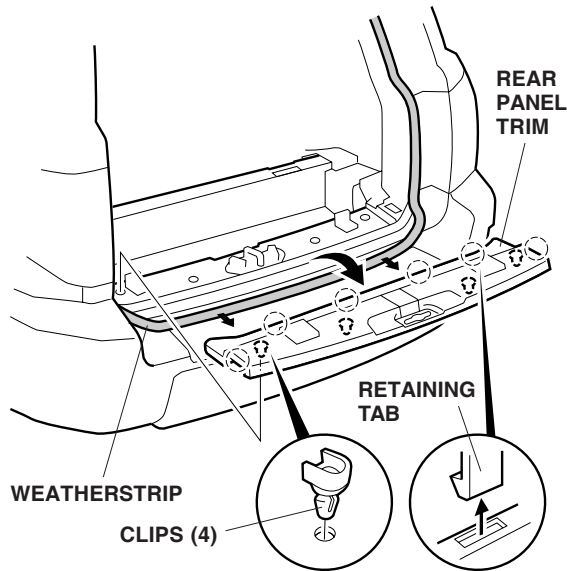

- Under the rear bumper, locate the large grommet on the driver's side of the vehicle. Remove and discard the large grommet from the hole in the body frame.

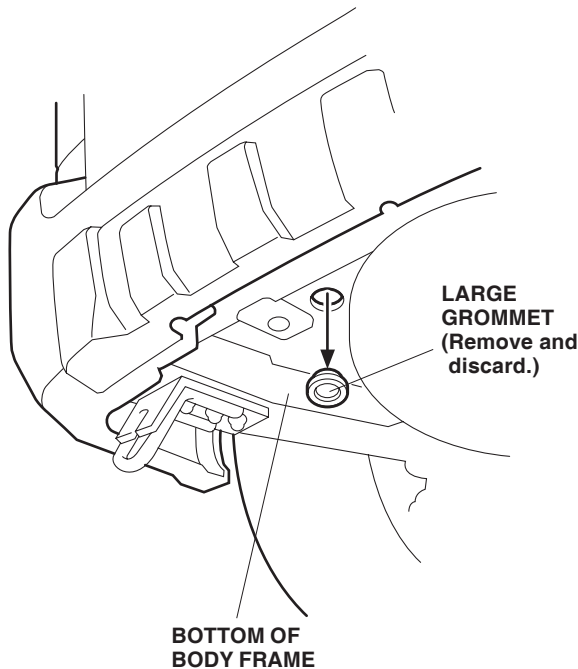

- Inside the vehicle, locate the grommet on the body panel. Remove and discard the grommet from the body panel.

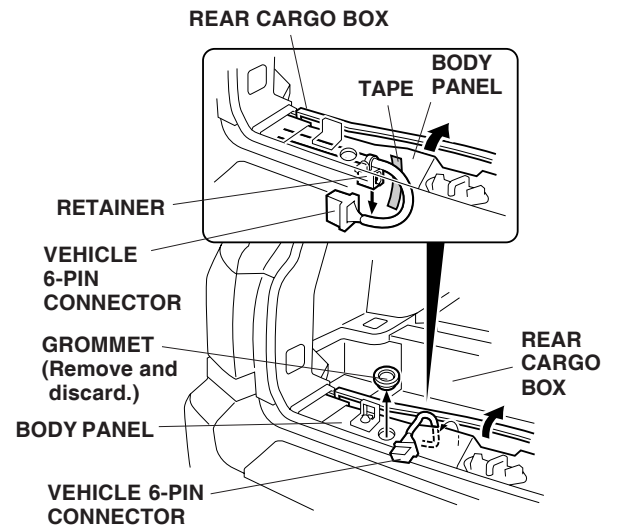

- Remove the tape from the vehicle 6-pin connector harness located in the space between the rear cargo box and the body panel. Pull out the vehicle 6-pin connector and remove the harness from the retainer.
- Remove the retainer from the body hole, then remove and discard the retainer from the vehicle harness. Take care not to damage the vehicle harness when removing the retainer.

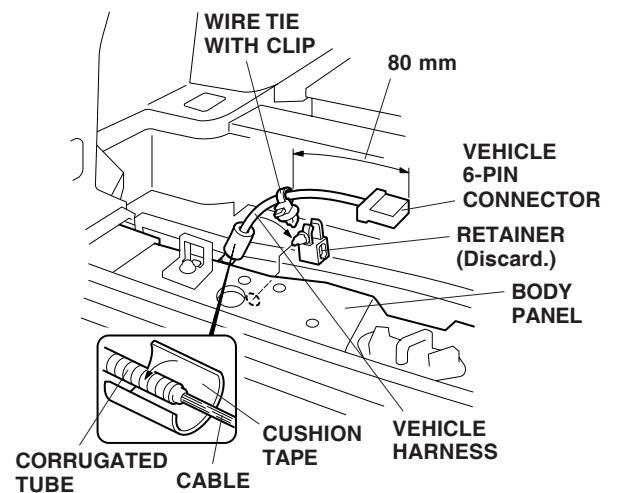

- Attach one wire tie with clip to the vehicle harness in the area shown. Wrap one cushion tape around the joint section between the corrugated tube of the vehicle harness and cable.

10. Using a utility knife, cut out the two marked areas from the corners of the template. Fold the template along the dotted lines.

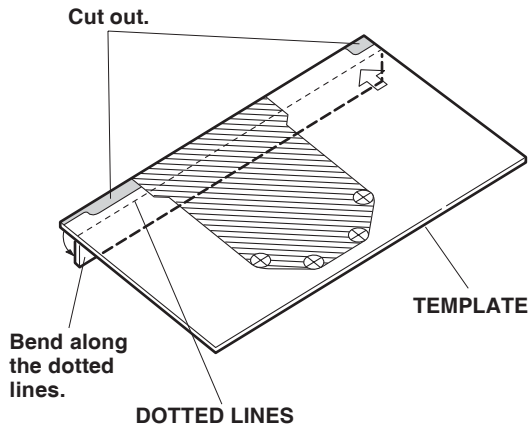

11. On the driver's side of the vehicle near the vehicle harness, tape the template inside the rear cargo box in the area shown.

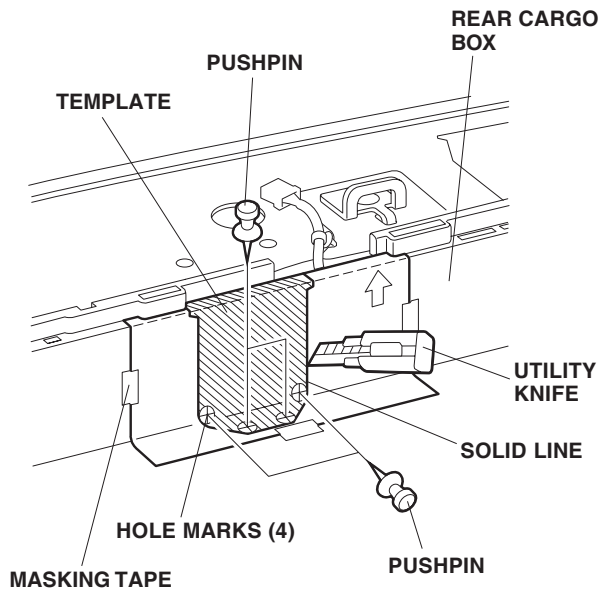

12. Using a pushpin, mark the rear cargo box at each of the four marks on the template. Using a utility knife, scribe the rear cargo box along the solid line on the template.

13. Remove the template. While wearing eye protection, drill a 10 mm hole through the center of each mark.

- To prevent drilling into the frame, wrap tape around the drill bit 8 mm away from the tip.
- First drill with a 3 mm drill bit, and finish with a 10 mm drill bit.

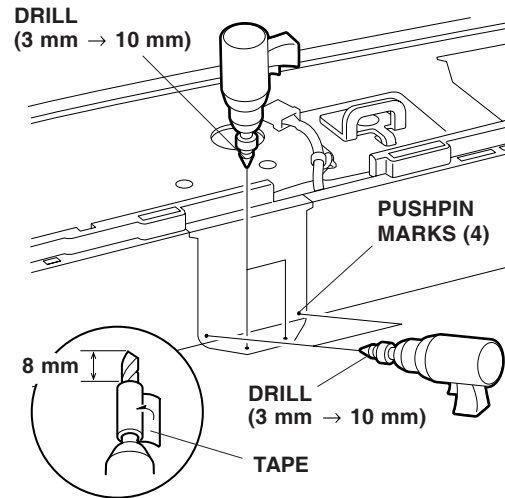

To prevent drilling into the frame, apply tape to the end of the drill bit

14. Using a utility knife, cut out the marked area from the rear cargo box. Remove all burrs and any plastic pieces.

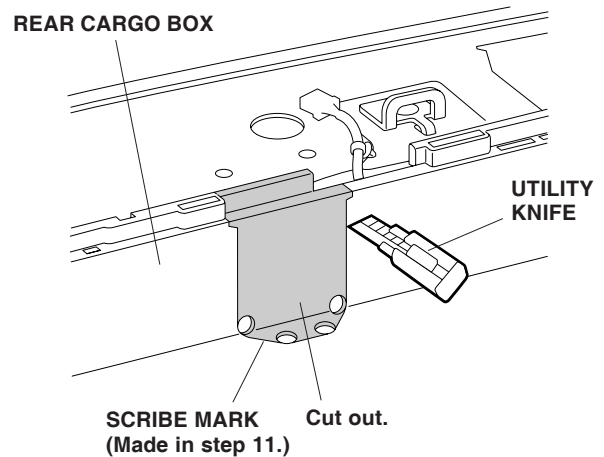

- Using a utility knife, cut one cushion tape into four pieces. Attach small pieces to the converter bracket in the four locations shown. Be careful not to cover the holes in the bracket. Use isopropyl alcohol to clean the area where the cushion tapes will attach.

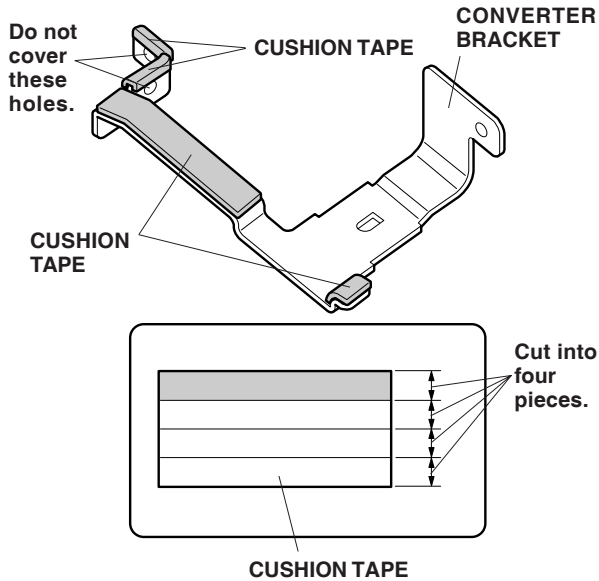

- Attach the wire tie with clip to the trailer hitch harness where the green tape is wrapped.

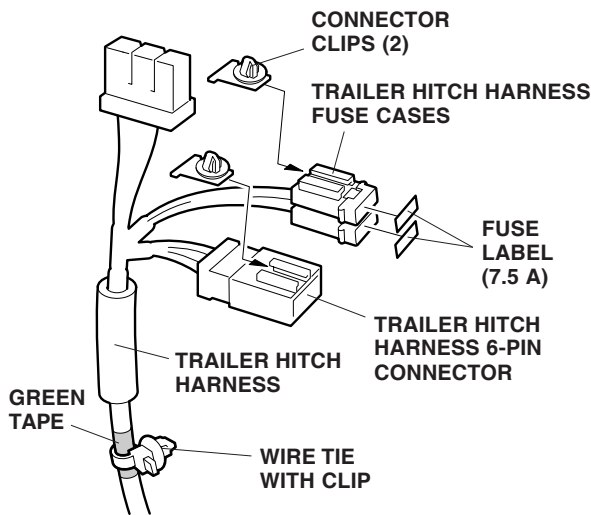

- Slide one connector clip onto the trailer hitch harness fuse case and one onto the trailer hitch harness 6-pin connector.
- Attach the fuse labels (7.5A) to the trailer hitch harness fuse cases.

- Slide the converter bracket onto the converter. Do not push on the connector when installing the converter bracket.

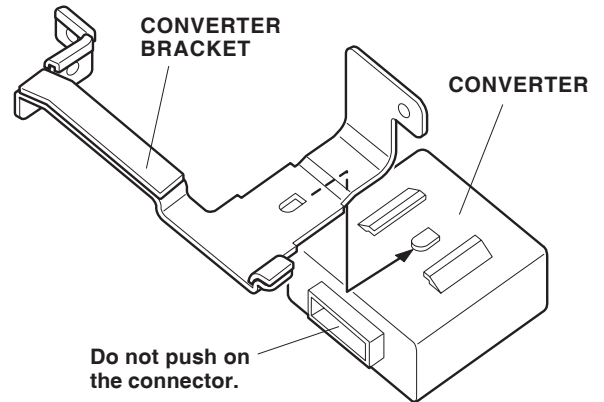

- Plug the trailer hitch harness 12-pin connector into the converter.

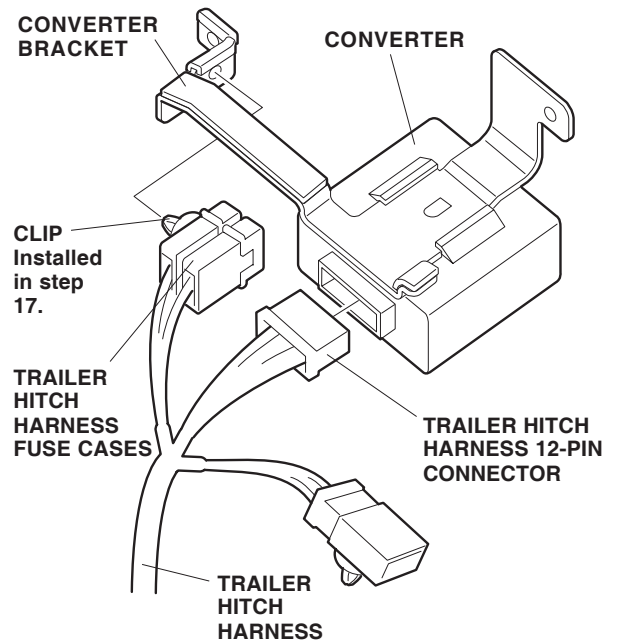

- Push the clip installed from the trailer hitch harness fuse case into the hole in the converter bracket.

22. Plug the vehicle 6-pin connector into the trailer hitch harness 6-pin connector, then push the wire tie with clip into the hole in the converter bracket.

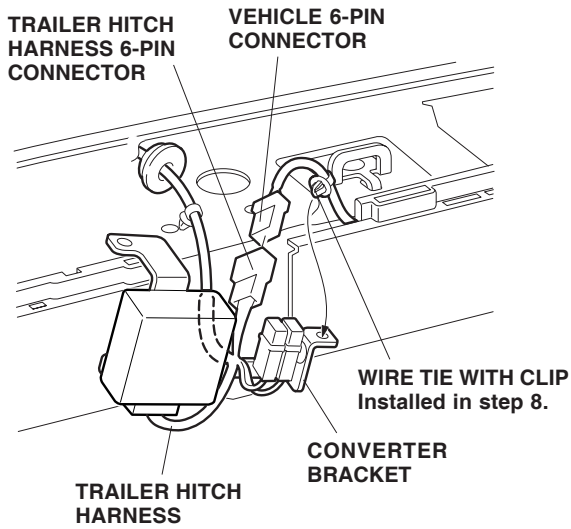

23. Fold the rear cargo box down, and position the converter bracket between the body panel and rear cargo box. Push the clip on the trailer hitch harness 6-pin connector into the body hole where the retainer was removed.

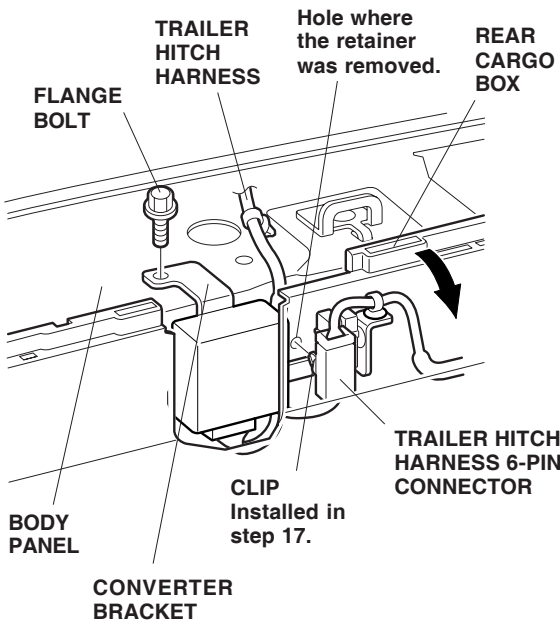

24. Align the hole in the converter bracket with the hole in the body panel and install the flange bolt.

25. Route the trailer hitch harness 4-pin connector through the hole in the upper body panel and out through the hole in the bottom body panel.

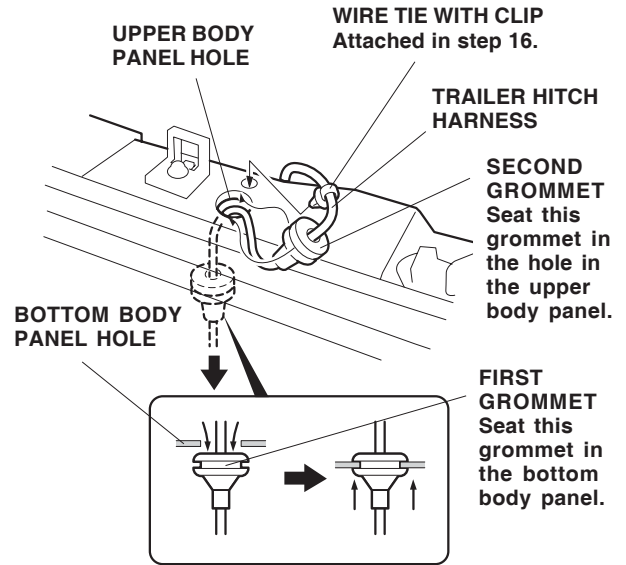

26. Pull the first grommet through the upper body panel hole, and seat the first grommet in the bottom body panel hole. Seat the second grommet in the upper body panel hole.
27. Attach the wire tie with clip (installed in step 16) to the hole in the upper body panel.
28. Install the converter cover on the rear cargo box to cover the converter.

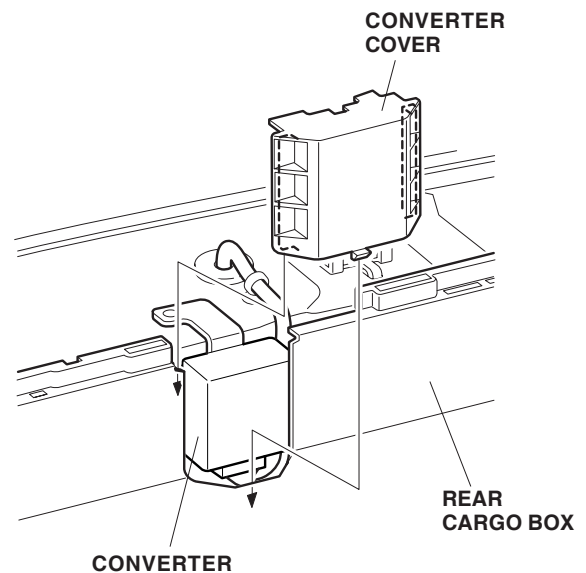

## Installing the Hitch

29. Using the wheel nut wrench (in the vehicle tool kit), lower the spare tire.

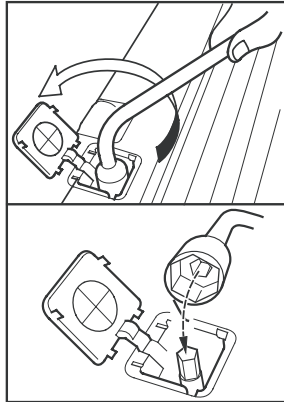

30. Under the rear bumper, locate the excess tabs. Using diagonal cutters, remove the tab and a small piece from the corner on the left side of the rear bumper in the area shown. Remove the tab and the corner piece from the right side of the rear bumper the same way.

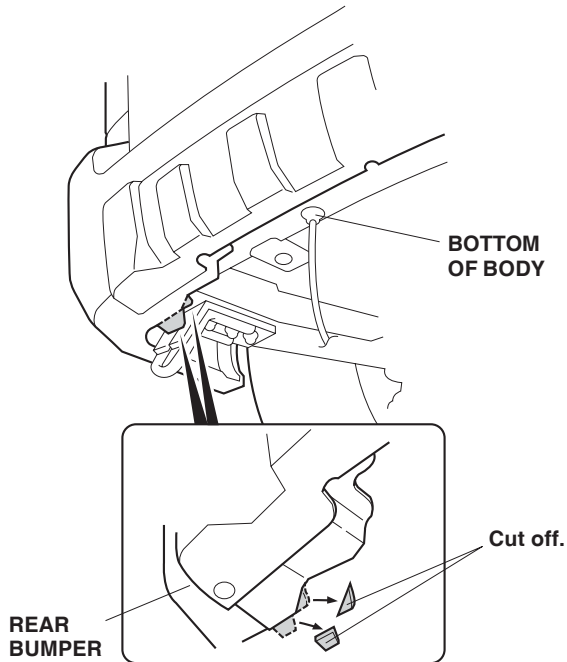

31. Remove the tow hook (three bolts). Save the tow hook and bolts for your customer.

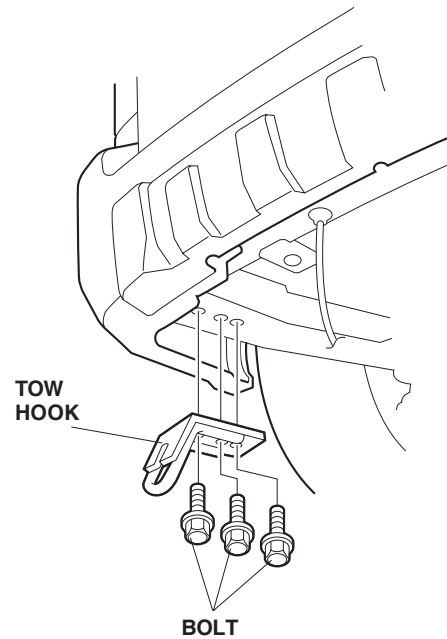

32. With the help of an assistant, install the trailer hitch to the body, using the eight 12 x 40 mm bolts, eight 12 mm plain washers, and eight 12 mm spring washers. Do not tighten the bolts yet.

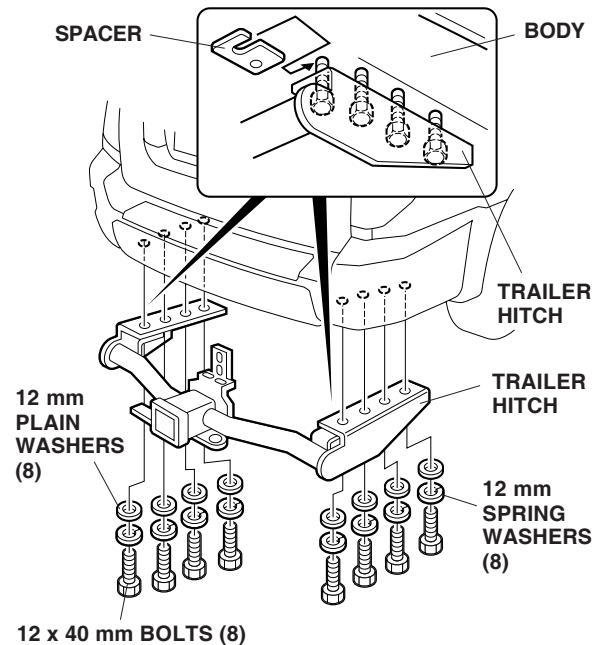

33. Insert one spacer on each side between the trailer hitch and the body at the rear bolts. Do not tighten the trailer hitch bolts at this time.

34. Loosely install the two 10 x 30 mm bolts, and the two 8 x 20 mm bolts, all with plain washers and with spring washers.

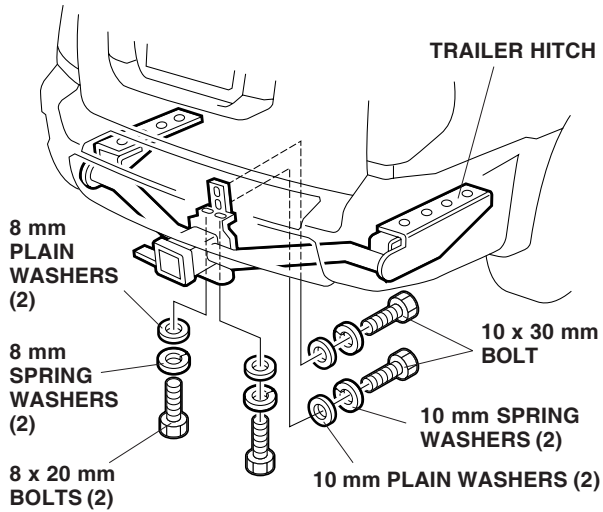

35. Torque the trailer hitch mounting bolts in this order:

**1**

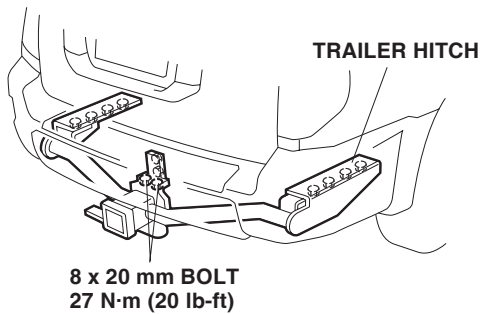

**2**

- Two 8 x 20 mm bolts to 27 N·m (20 lb-ft).

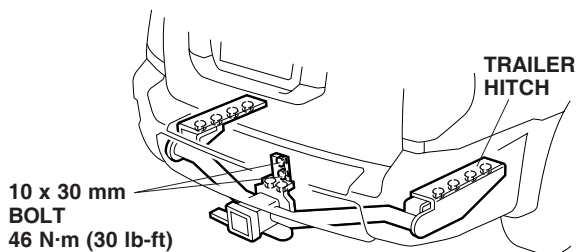

**3**

- Two 10 x 30 mm bolts to 46 N·m (33 lb-ft).
- Eight 12 x 40 mm bolts (installed in step 32) to

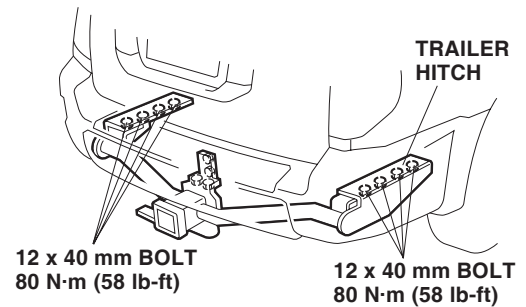

- 80 N·m (58 lb-ft).
36. Attach the trailer hitch harness connector to the harness connector bracket, and install the bracket to the trailer hitch with the flange bolt and flange

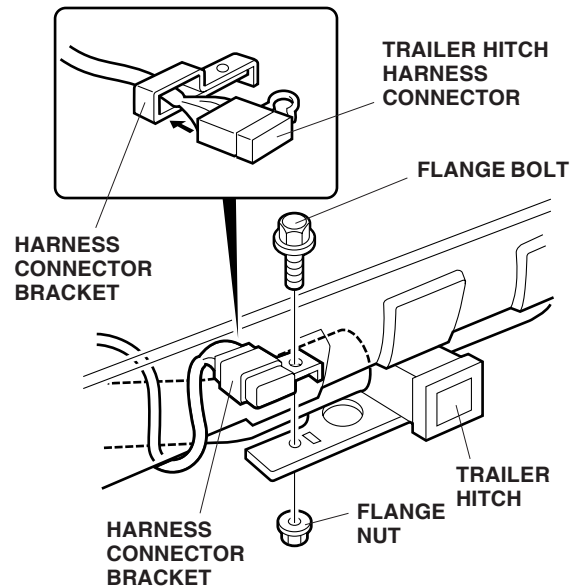



nut.

37. Secure the trailer hitch harness to the trailer hitch

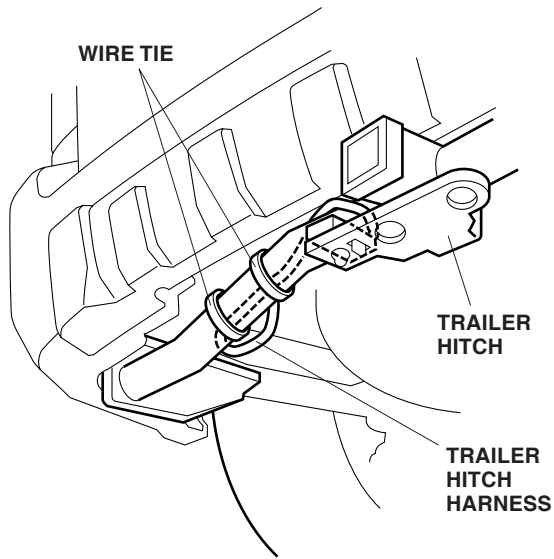

with two wire ties in the areas shown.

38. Slide the ball mount into the opening at the end of

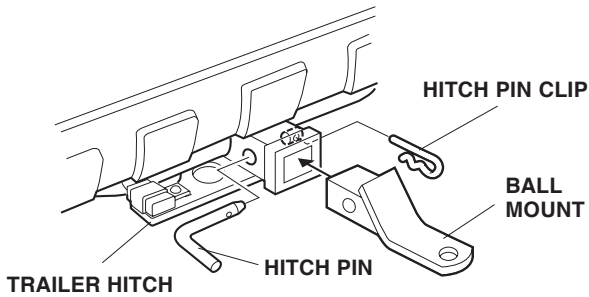

the trailer hitch.

39. Slide the hitch pin through the trailer hitch and ball mount, then install the hitch pin clip in the hole in

- the end of the hitch pin.  
40. On the back of the rear panel trim, locate the rib in the area where the converter bracket was installed. Using a utility knife, cut the two ribs

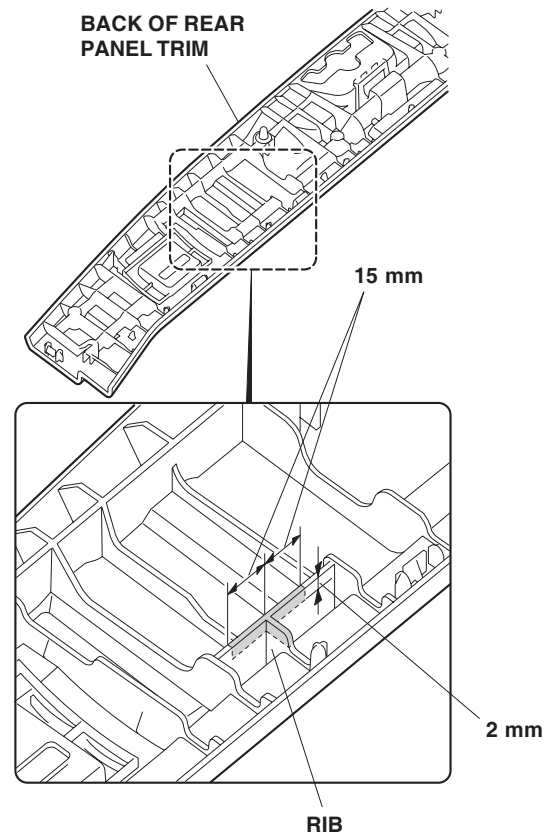

- using the measurement shown.  
41. Raise the spare tire back into position, then reinstall the rear panel trim, the tailgate

weatherstrip, and the cargo floor lid.

42. Inside the engine compartment, open the relay box cover and install the 20A fuse block in the

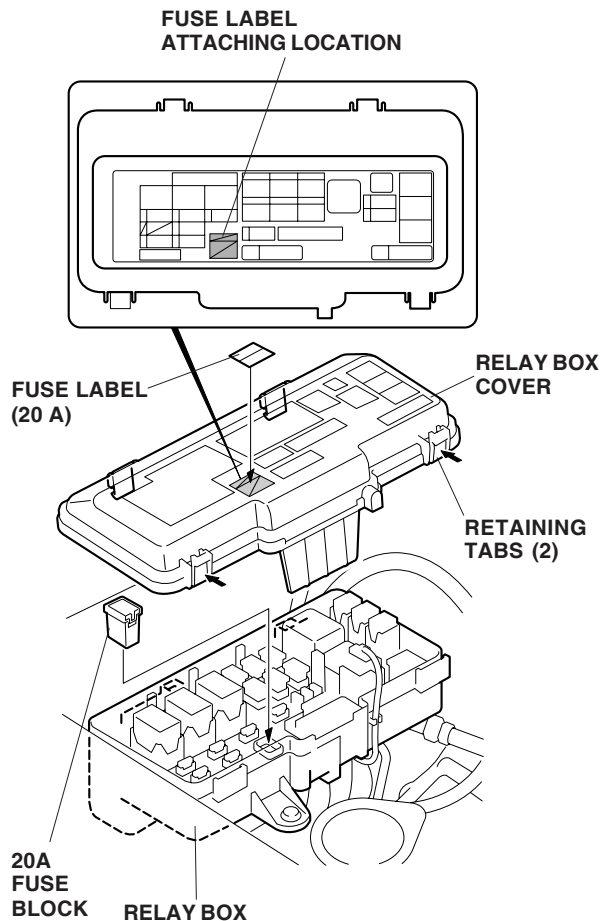

relay box as indicated.

43. Using isopropyl alcohol, clean the relay box cover where the fuse label (20A) will attach. Install the 20A fuse label to the relay box cover, then reinstall the relay box cover.
44. Reconnect the negative cable to the battery.
45. Enter the customer's radio anti-theft code, and reset the radio station presets.
46. Reset the clock.

**NOTE:** Whenever the battery is disconnected, the driver's window AUTO function is disabled.

47. Start the engine. Push down on the driver's window switch until the window is fully open.
48. Pull up on the driver's window switch to close the window completely, then hold the switch for 2 seconds or more.
49. Lower and raise the window to check operation of

50. Do the ECM/PCM idle learn procedure.

- Make sure all electrical items are turned off.
- Start the engine. Hold the engine speed at 3,000 rpm with no load (in Park or Neutral) until the radiator fan comes on.
- Let the engine idle for about 5 minutes with the throttle fully closed and with all electrical items off.

**NOTE:** If the radiator fan comes on during this step, the time when it is operating must not be included in the 5 minutes.

the driver's window AUTO function.

### Give a copy of this page to your customer Installing the Receiver Cover

Whenever you remove the hitch pin clip, the hitch pin, and the ball mount, store them securely in the cargo area. Install the receiver cover into the opening at the end of the trailer hitch. When you reinstall the ball mount, store the receiver cover in the cargo area. After the first 600 miles (1,000 km) of towing, have your Honda Dealer recheck the tightness of the trailer hitch bolts.

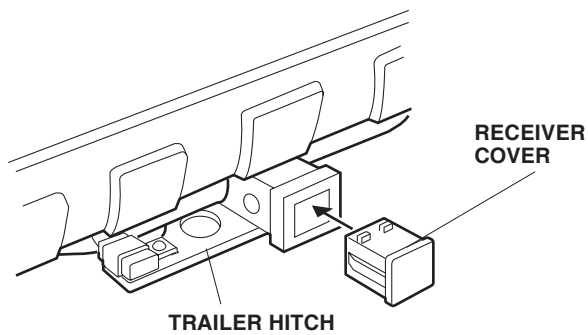

### To Trailer:

- Y Yellow = Brake/Left Turn
- G Green = Brake/Right Turn
- BR Brown = Small Lights (Park lights)
- W White = Ground

