

HONDA
INSTALLATION
INSTRUCTIONS

Accessory
TRAILER HARNESS

Application
2009 PILOT

Publications No.
All 39422
 Issue Date
MAY 2008

PARTS LIST

Trailer Harness Kit
P/N 08L91-SZA-100 Sold Separately

Trailer socket harness

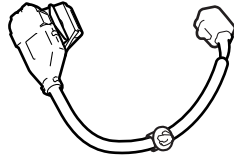

Socket bracket

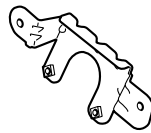

2 Fuses 7.5A

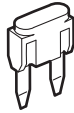

2 Fuses 20A

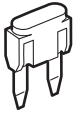

Fuse 30A



2 Washer-bolts, 6 x 16 mm

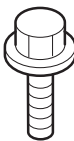

4 Flange bolts, 6 x 16 mm

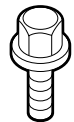

Sub harness kit

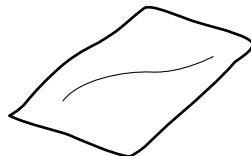

Control unit

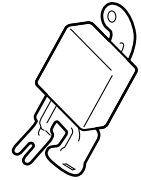

2 Relays

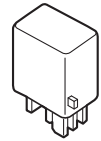

Towing Kit
P/N 08L92-SZA-100 Sold Separately

Ball mount

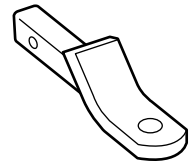

Locking pin

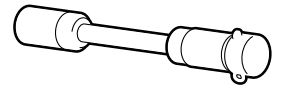

2 Keys



Receiver cover



Box

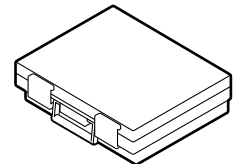

TOOLS AND SUPPLIES REQUIRED

Flat-tip screwdriver
Phillips screwdriver
Ratchet
10 mm Socket
Combination wrench
Plastic trim tool
(T/N SILTRIMTL10)
Utility knife

Illustration of the Trailer Harness Installed on the Vehicle

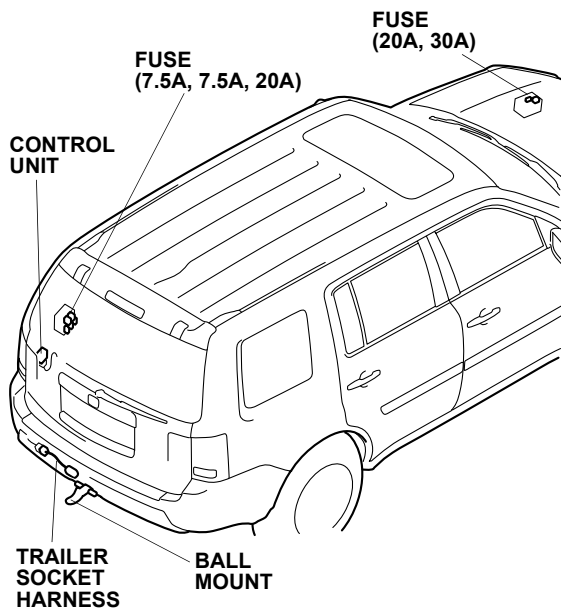

INSTALLATION

Customer Information: The information in this installation instruction is intended for use only by skilled technicians who have the proper tools, equipment, and training to correctly and safely add equipment to your vehicle. These procedures should not be attempted by "do-it-yourselfers."

NOTE:

1. Make sure you have the anti-theft code for the radio, then write down the radio station presets.
2. Disconnect the negative cable from the battery.

Installing the Control Unit

3. Pull the knob, and open the cover from the left rear side lining (two retaining tabs).

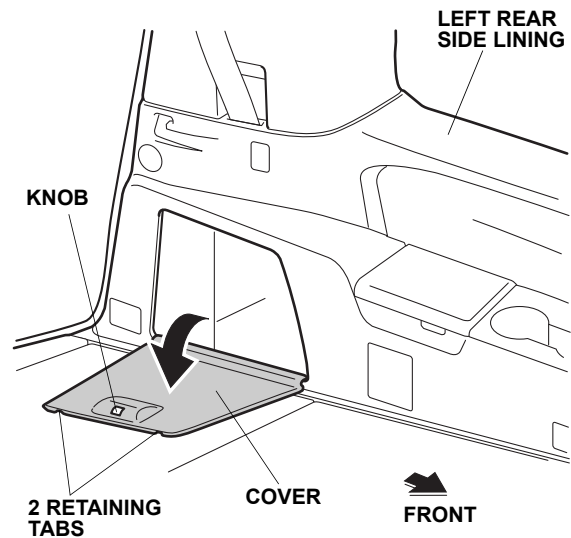

4. Pull the knob, and remove the cover from the left rear side lining (six retaining clips and two hooks).

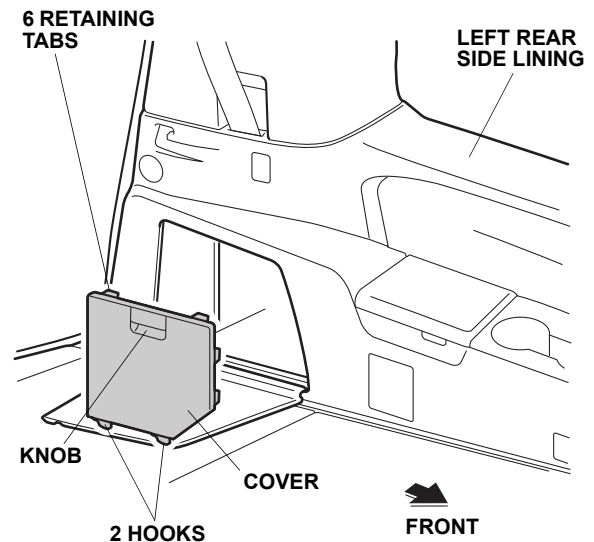

5. Locate the vehicle 12-pin connector, and remove the blue tape from the vehicle harness.

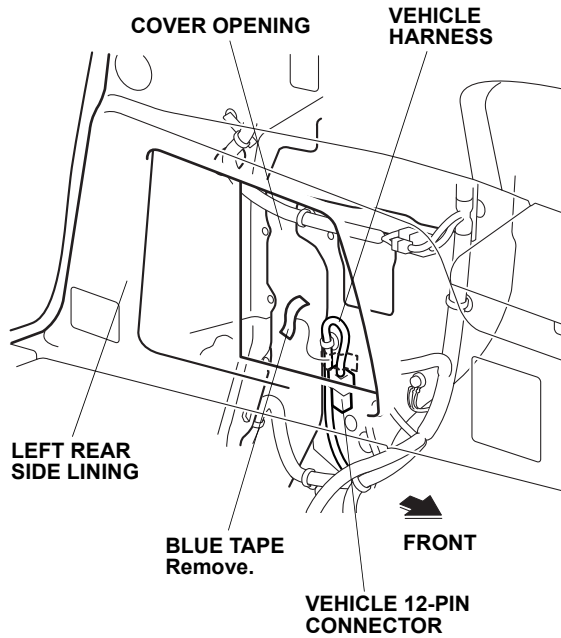

6. Secure the control unit to the vehicle panel with two 6 x 16 mm flange bolts.

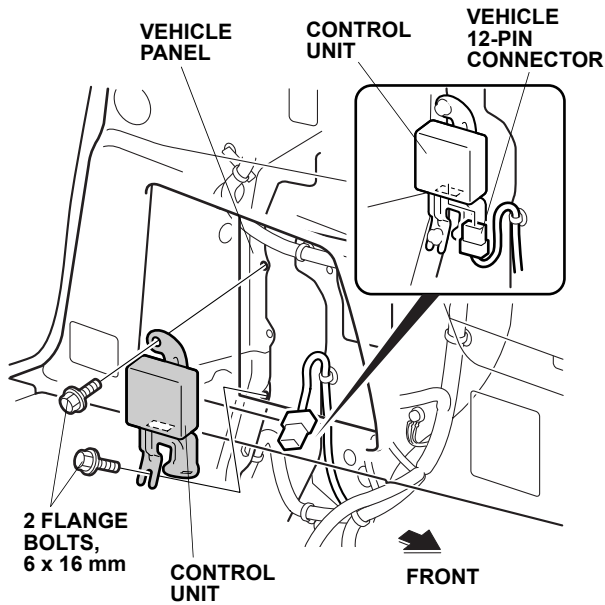

7. Plug the vehicle 12-pin connector to the control unit.

Routing the Trailer Socket Harness

8. Remove the lid from the rear bumper (eight retaining tabs).

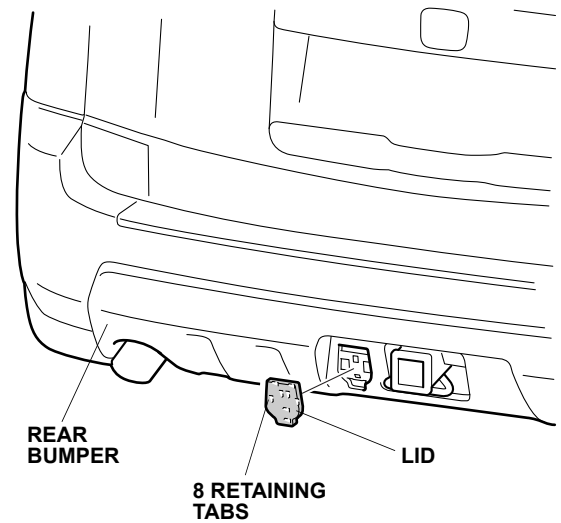

9. Using a utility knife, cut out the rear bumper from the lid opening as shown.

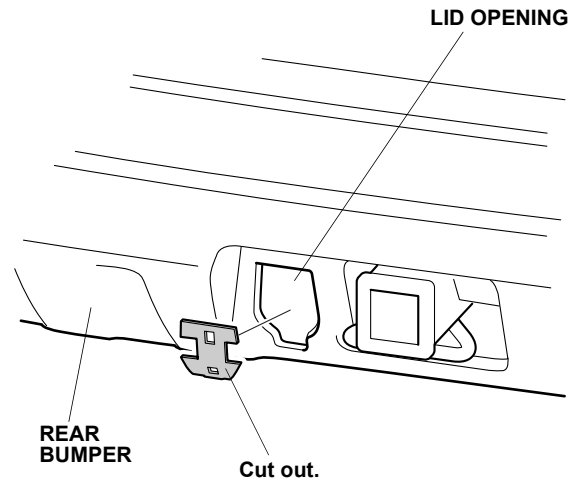

10. Install the socket bracket on the trailer socket harness with two 6 x 16 mm flange bolts.

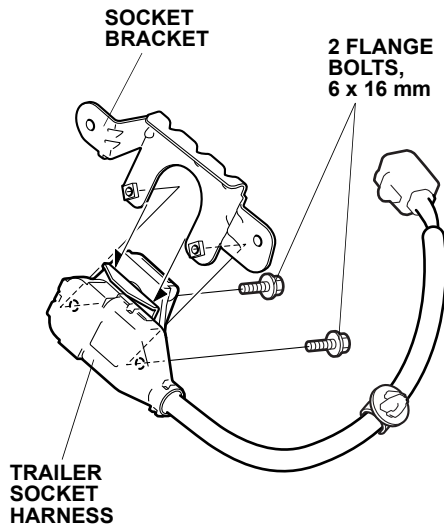

11. Secure the trailer socket harness to the vehicle frame with two 6 x 16 mm washer bolts.

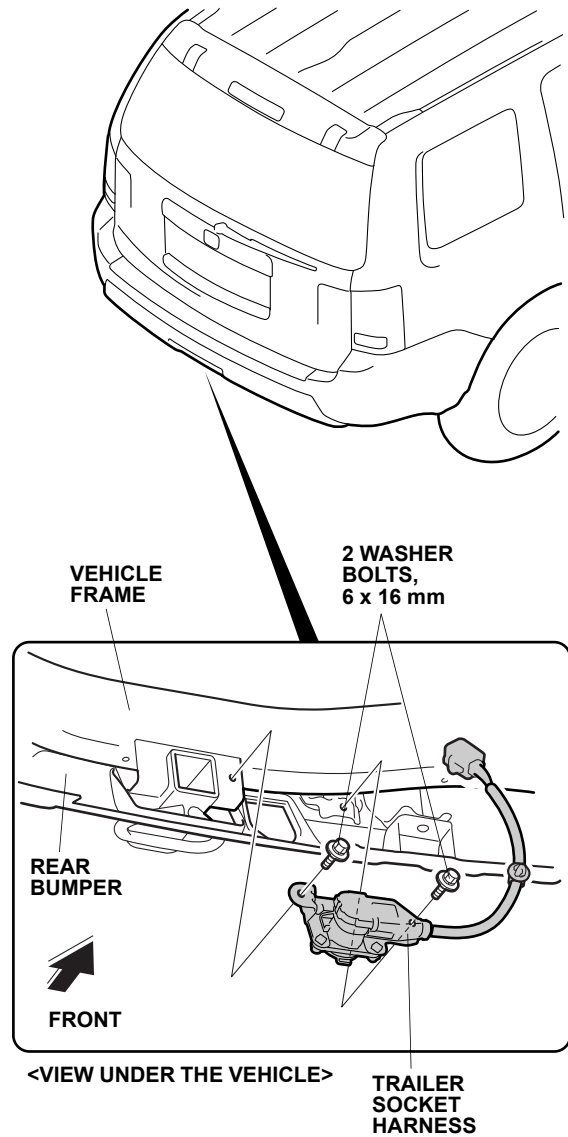

- Release the vehicle 10-pin connector from the connector clip, and remove the dummy connector from the vehicle 10-pin connector.

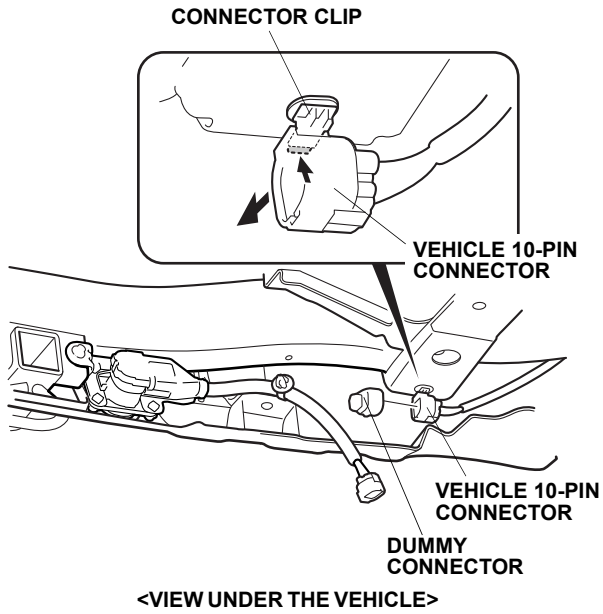

- Plug the trailer socket harness 10-pin connector to the vehicle 10-pin connector.

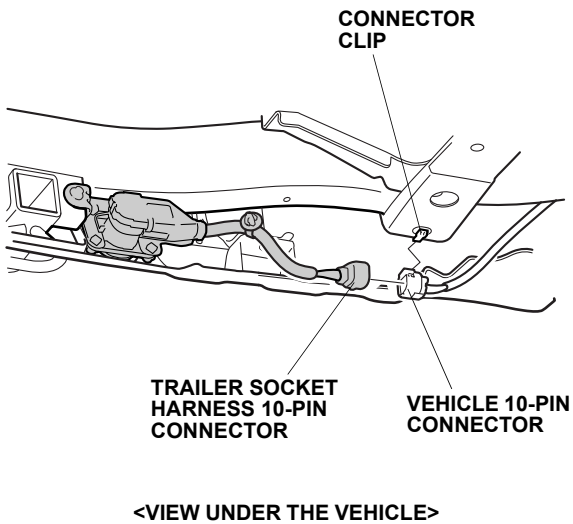

- Secure the 10-pin connectors to the connector clip from which you released the vehicle 10-pin connector in step 12.

- Install the trailer socket harness clip on the vehicle frame.

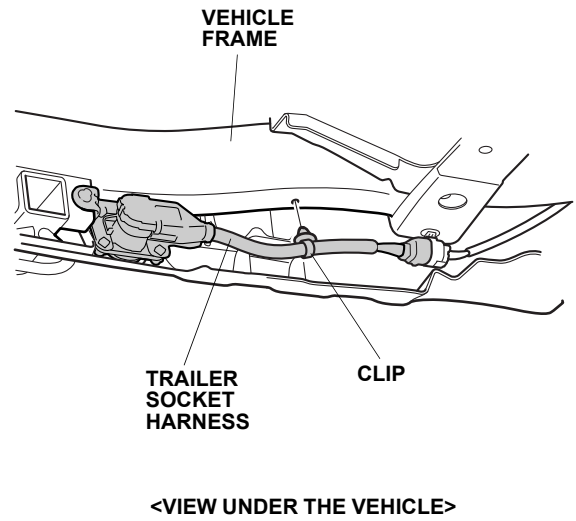

- In the cargo area, remove the lid from the left rear side lining (four retaining tabs and two hooks).

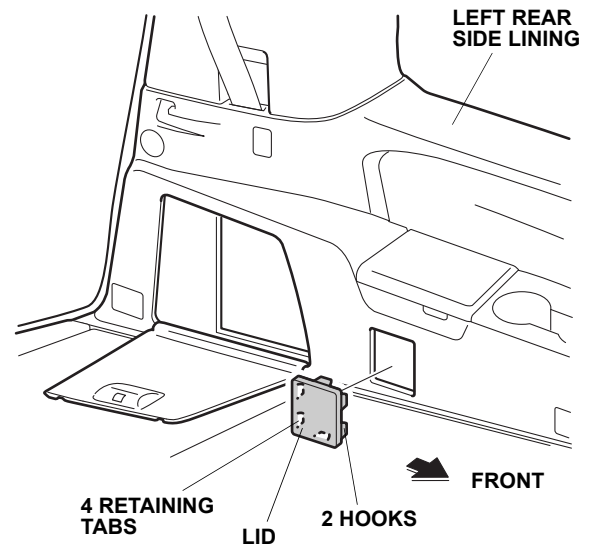

17. Remove the fuse cover from the fuse case (two retaining tabs).

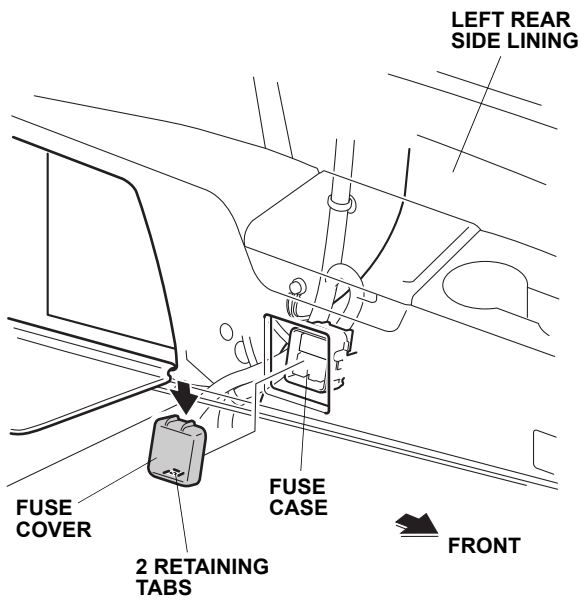

18. Plug the two 7.5A fuses and one 20A fuse to the fuse case.

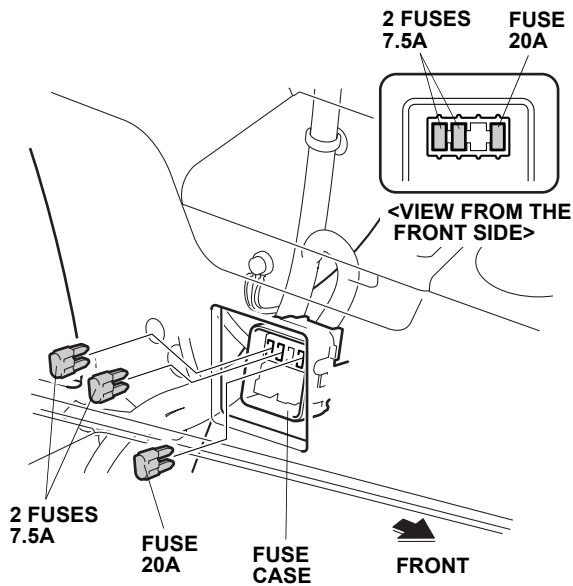

19. Plug the two relays to the relay block in the fuse case.

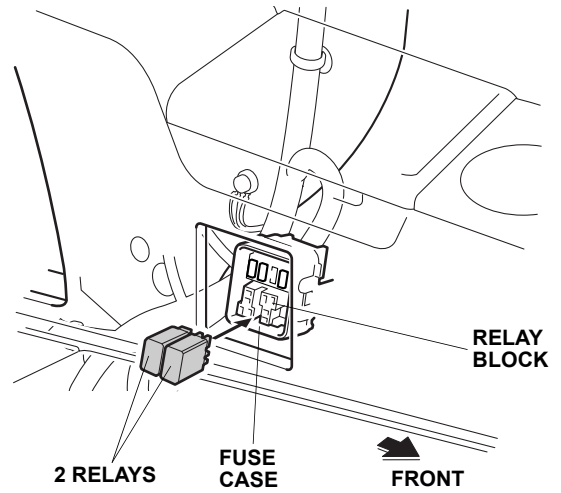

20. Open the hood.

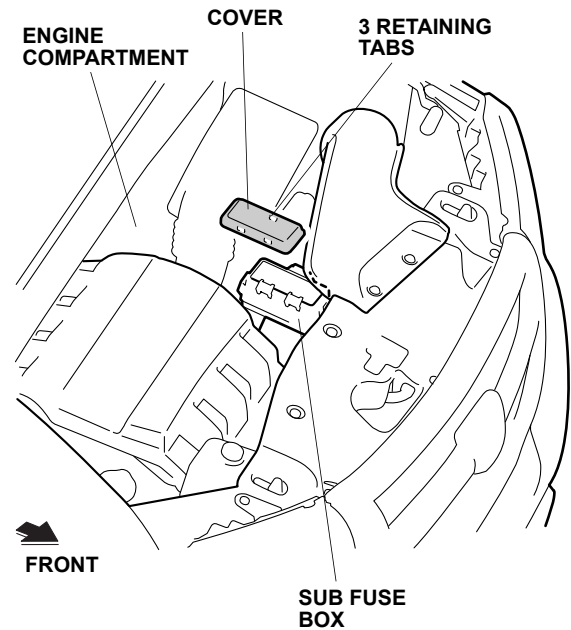

21. In the engine compartment, remove the cover from the sub fuse box (three retaining tabs).

22. Plug the 20A fuse and 30A fuse to the sub fuse box.

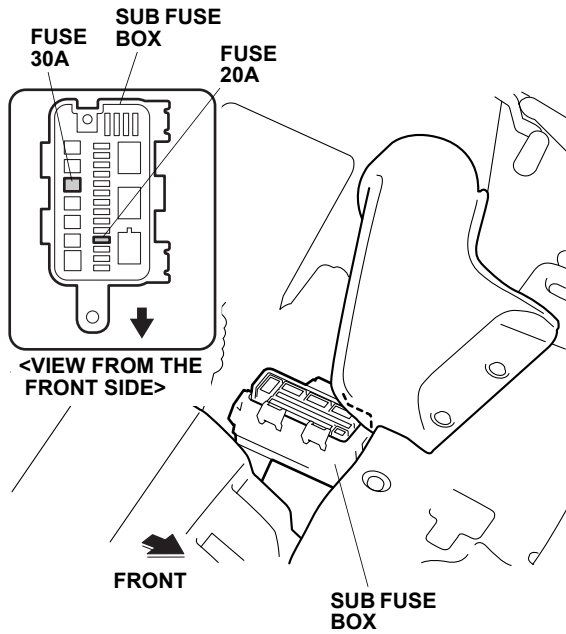

23. Check that all wire harnesses are routed properly and all connectors are plugged in.
24. Reinstall all removed parts. Check that all clips and fasteners are installed securely.
25. Reconnect the negative cable to the battery.
26. Reset the clock, and reset the radio station presets.

Installing Tow Hitch kit

27. Insert the ball mount into the vehicle frame, and secure it with the locking pin.

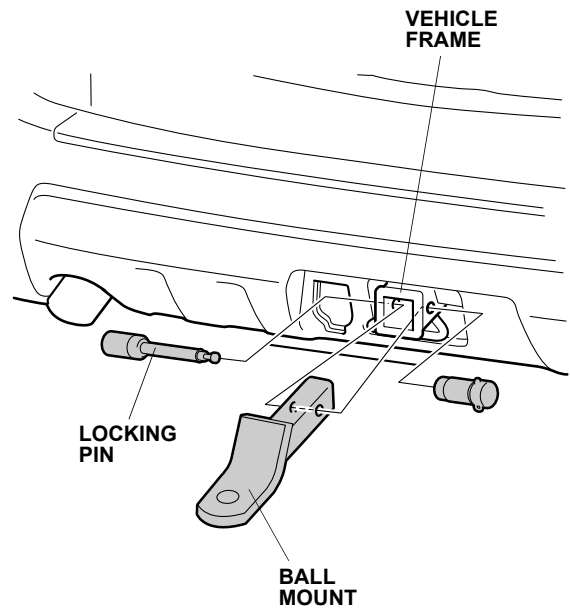

Put a Copy of This Page in the Glove Box for Your Customer

Installing the Receiver Cover

Whenever you remove the hitch pin clip, the hitch pin, and the ball mount, securely store them in the cargo area. Then install the receiver cover into the opening at the end of the trailer hitch. When you reinstall the ball mount, store the receiver cover in the cargo area.

