



INSTALLATION INSTRUCTIONS

Accessory MOONROOF VISOR P/N 08R01-SZA-100	Application 2009 PILOT	Publications No. All 39409
		Issue Date MAY 2008

PARTS LIST

Moonroof visor

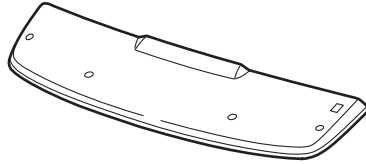

2 Brackets A



2 Brackets B

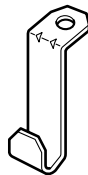

4 Screws



4 Nuts



4 Protection films



2 Alcohol swabs

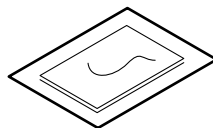

2 EPT sealers (not used)

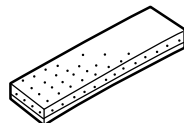

TOOLS AND SUPPLIES REQUIRED

Phillips screwdriver

10 mm Combination wrench

Scale

Isopropyl alcohol

Shop towels

Masking tape

Felt-tip pen

Torque screwdriver: T/N CDI401SM

Illustration of the Moonroof Visor Installed on the Vehicle

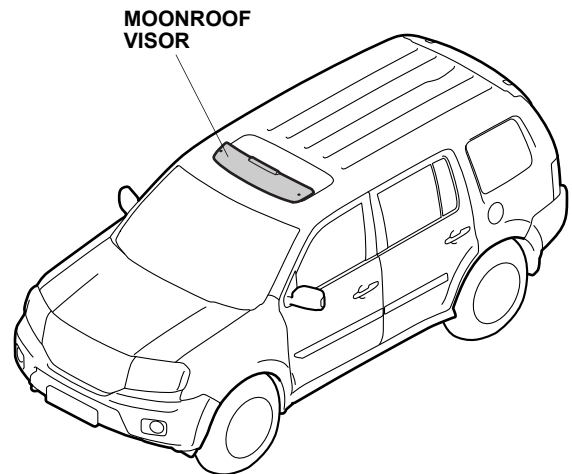

INSTALLATION

Customer Information: The information in this installation instruction is intended for use only by skilled technicians who have the proper tools, equipment, and training to correctly and safely add equipment to your vehicle. These procedures should not be attempted by "do-it-yourselfers."

NOTE:

- Install the accessory with care to avoid damaging the vehicle.
- Install the accessory using the specified bolts and screws. Use of unspecified bolts/screws may cause damage to the vehicle.
- Wash and wax the area to be covered. Use a high-quality paste wax.

1. Open the moonroof.

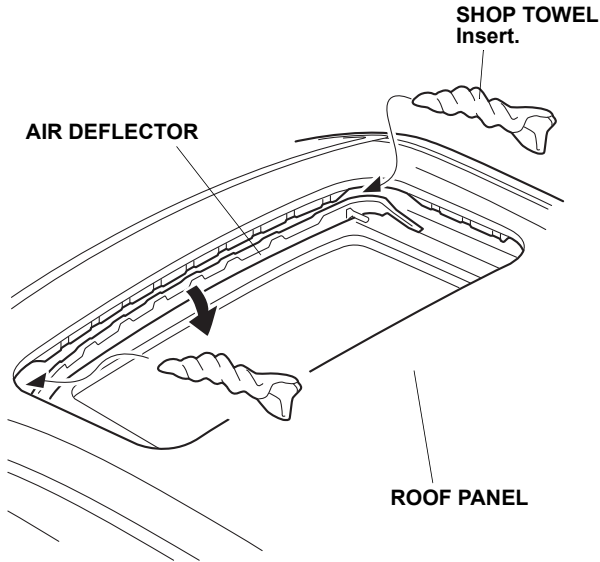

2. Roll up two shop towels and insert them between the roof panel and air deflector to lower the air deflector. Do not to damage the air deflector.

3. Using isopropyl alcohol on a shop towel, thoroughly clean the areas where the protection films will attach.

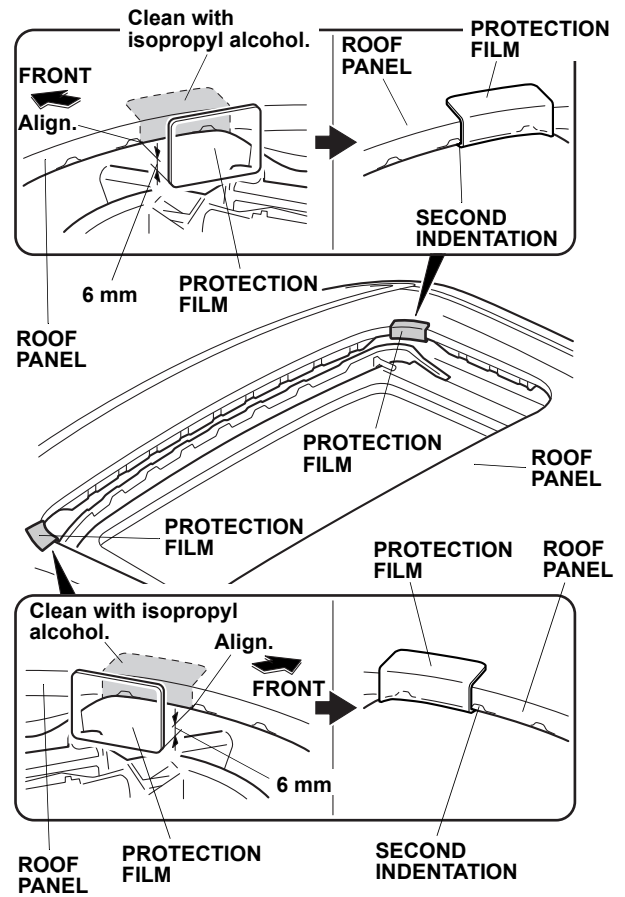

4. Remove the adhesive backings from the protection film. Starting from the bottom edge of the protection film, wrap 6 mm of the protection film around the lip of the roof panel opening and align it with the second indentation on the left side of the roof panel as shown; continue upward with the protection film around the top of the roof panel. Repeat the procedure on the right side of the roof panel.

- Using isopropyl alcohol on a shop towel, thoroughly clean the areas where the protection films will attach.

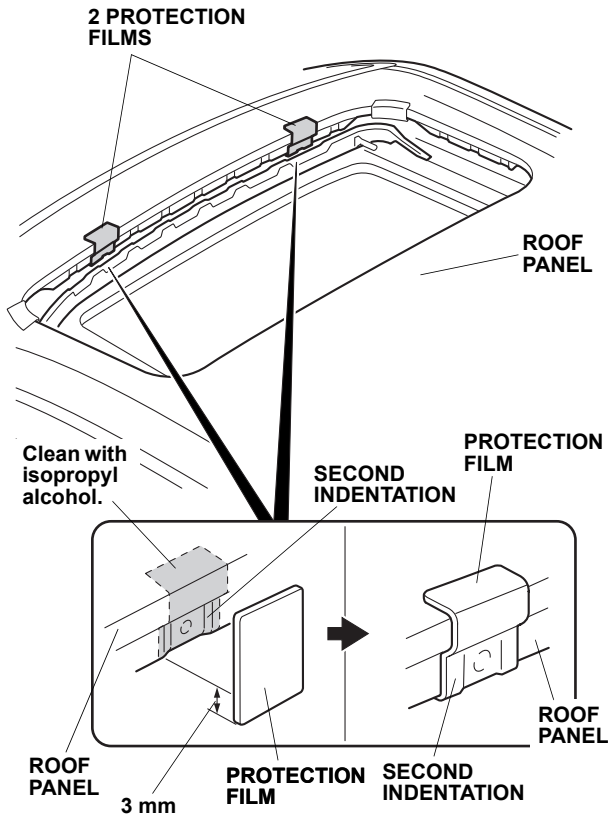

- Remove the adhesive backings from the protection film. Starting from the bottom edge of the protection film, wrap 3 mm of the protection film around the lip of the roof panel opening to cover the second indentation on the left side of the roof panel; continue upward with the protection film around the top of the roof panel. Repeat the procedure on the right side of the roof panel.

- Place two brackets B over the protection films attached in step 4 and secure them with the masking tapes as shown.

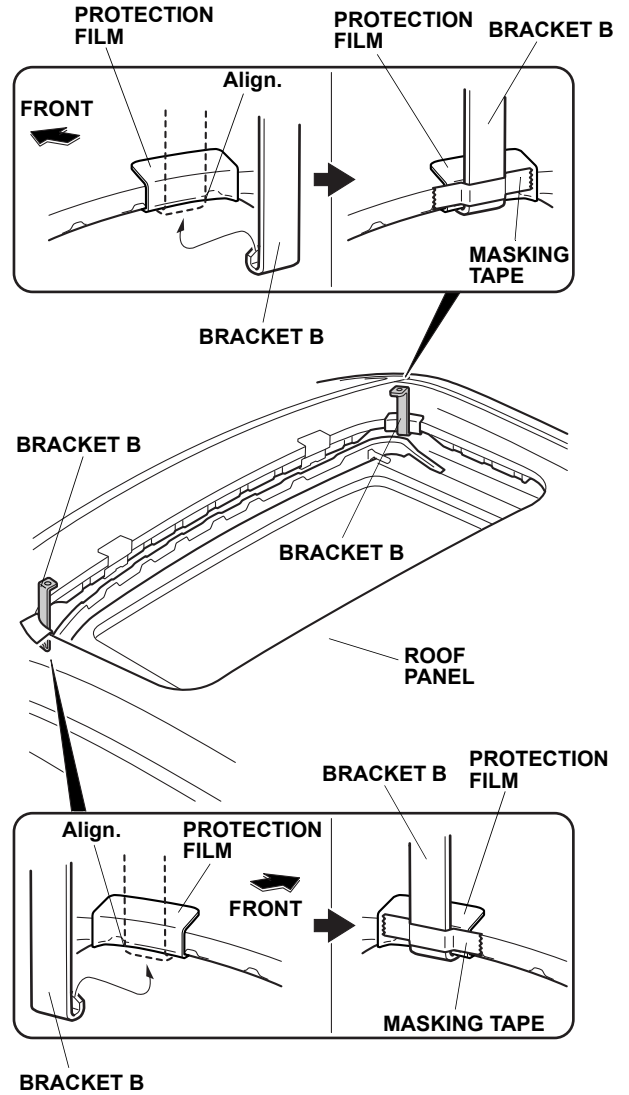

8. Place two brackets A over the protection films attached in step 6 and secure them with the masking tapes as shown.

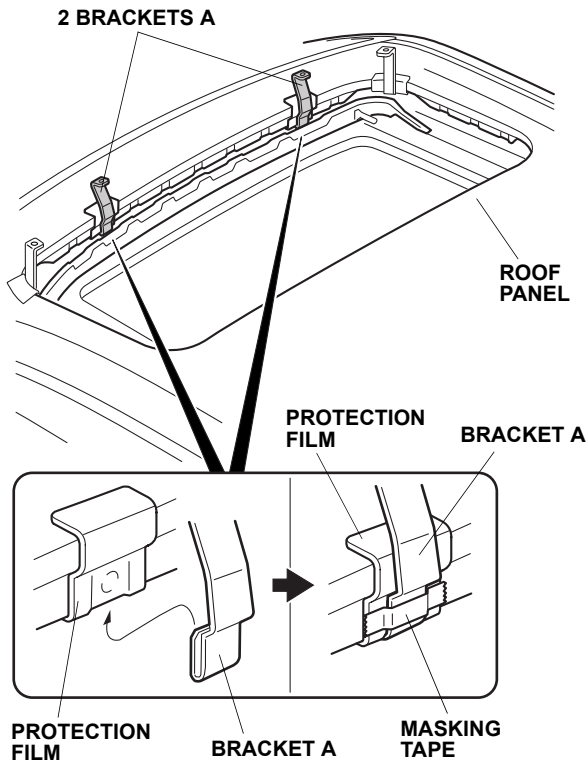

9. Align the holes on the moonroof visor with the holes on the brackets A and B. Secure the moonroof visor with four screws and four nuts. Do not tighten the screws and the nuts yet.

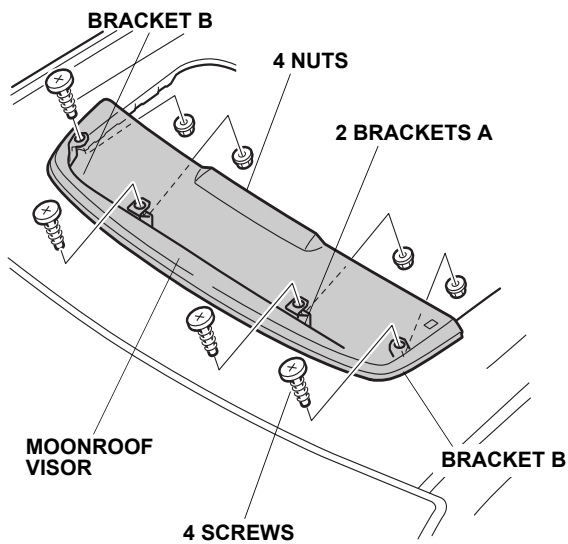

10. Adjust the position of the moonroof visor. Check that the brackets A and brackets B are firmly secured. Make sure the rubber molding on the moonroof visor is not twisted or rolled under the visor.

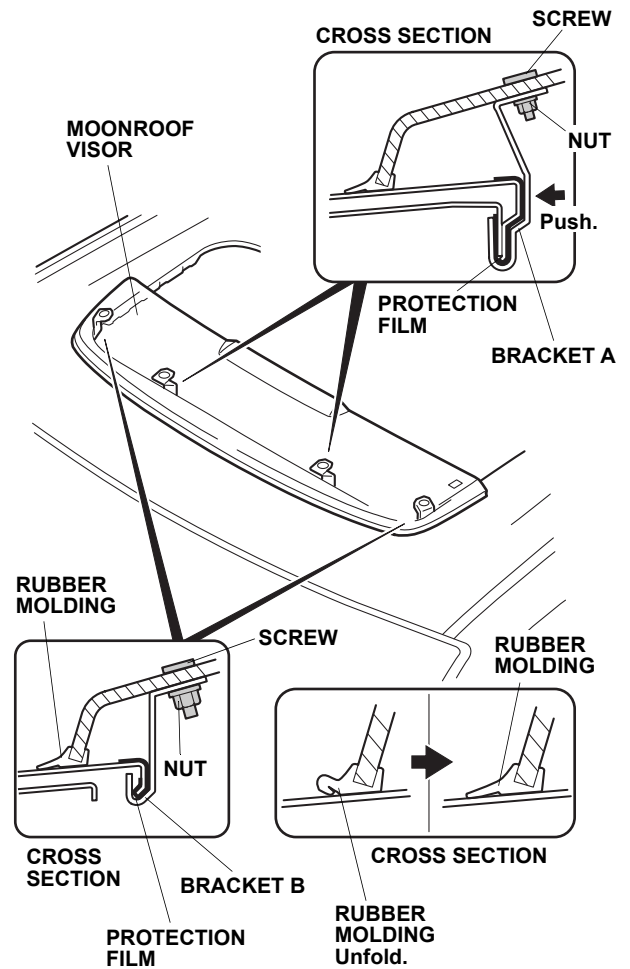

11. Tighten the screws and nuts while applying pressure against the brackets A. Make sure that there is no clearance between the brackets and the visor but do not overtighten the screws. Torque the screws and nuts to 2 N·m (1.5 lbf·ft).
12. Remove the masking tapes and the shop towels.
13. Remove one IMPORTANT INFORMATION label from the moonroof visor.

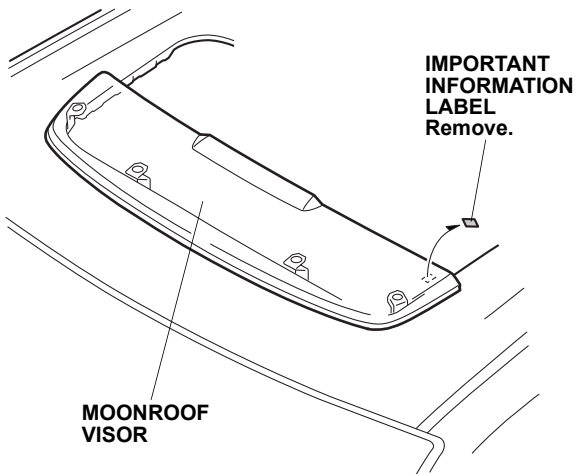

CARE OF THE MOONROOF VISOR

- To avoid damaging the surface, never use ammonia-based cleaners or solvents to clean the moonroof visor.
- Clean with a solution of mild dishwashing soap and a soft cloth or chamois.
- To remove scratches and restore the original luster, use Meguiar's Mirror Glaze plastic cleaner and polish or an equivalent high-quality plastic cleaner.