



# INSTALLATION INSTRUCTIONS

Accessory	Application	Publications No.
<b>AUTOMATIC DAY/NIGHT MIRROR</b>	<b>PILOT</b>	<b>All 23597</b>
		Issue Date
		<b>MAY 2002</b>

## PARTS LIST

**Automatic Day/Night Mirror Attachment Kit  
P/N 08V03-S9V-100A**

Day/night mirror

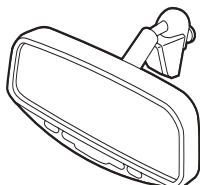

Upper cover

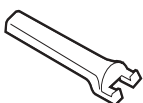

Lower cover

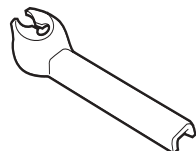

Day/night mirror harness

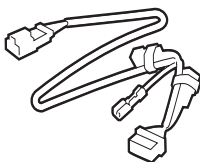

Mirror harness



9 Wire ties



5 Cushion tapes

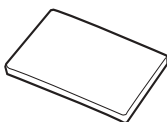

Owner's Manual

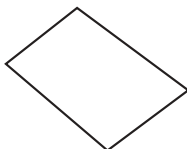

Spring clip

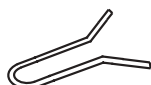

## TOOLS AND SUPPLIES REQUIRED

- Phillips screwdriver
- Small flat-tip screwdriver
- T25 Torx bit
- Diagonal cutters
- Isopropyl alcohol
- Shop towel
- Piece of steel wire
- Electrical tape

### Illustration of the Day/Night Mirror Installed on the Vehicle

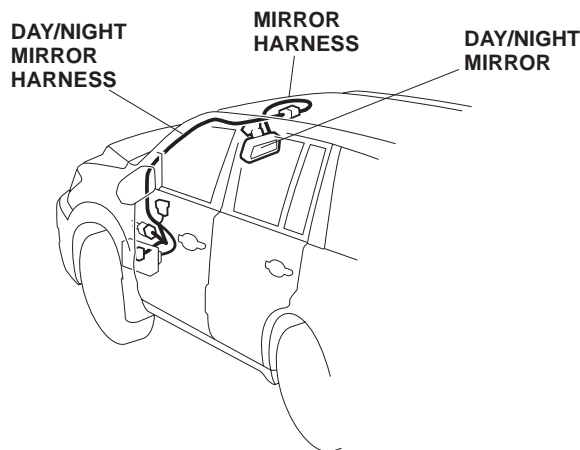

## INSTALLATION

**Customer Information:** The information in this installation instruction is intended for use only by skilled technicians who have the proper tools, equipment, and training to correctly and safely add equipment to your vehicle. These procedures should not be attempted by "do-it-yourselfers."

1. Make sure you have the anti-theft code for the radio, then write down the frequencies for the preset buttons.
2. Disconnect the negative cable from the battery.

- Remove the lens from the roof console (four retaining tabs).

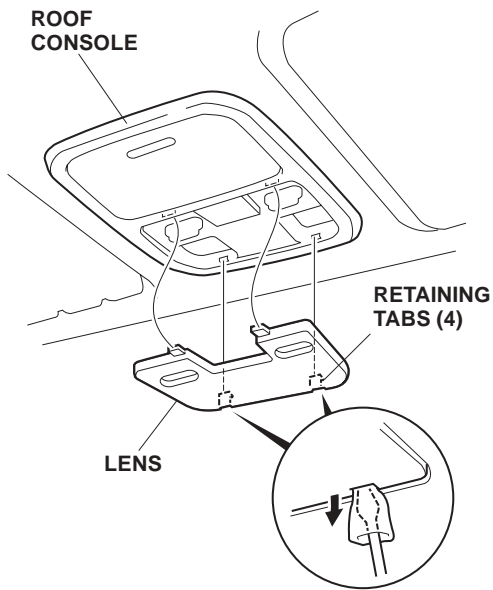

- Remove the roof console (four screws, and unplug one connector).

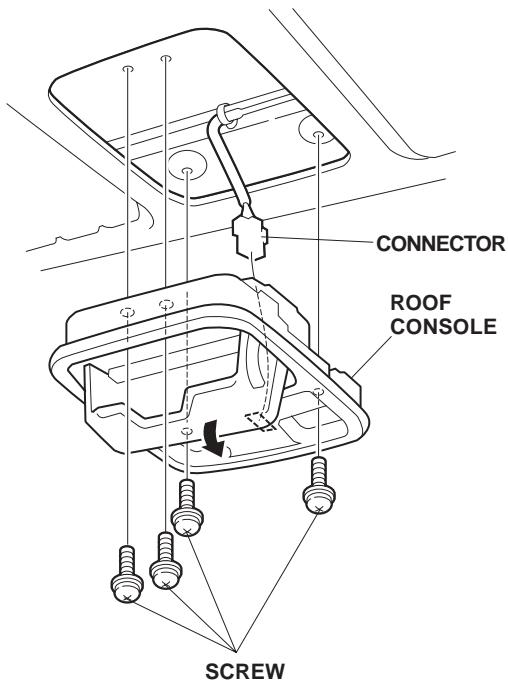

- Remove the rearview mirror from the holder by rotating the stay clockwise.

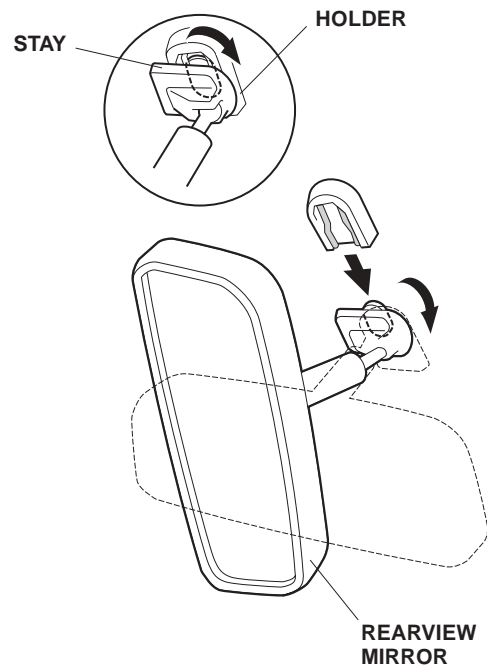

- Remove the sunvisor holders. Using a flat-tip screwdriver, push the hook, and turn the holder 90°, then pull it out.

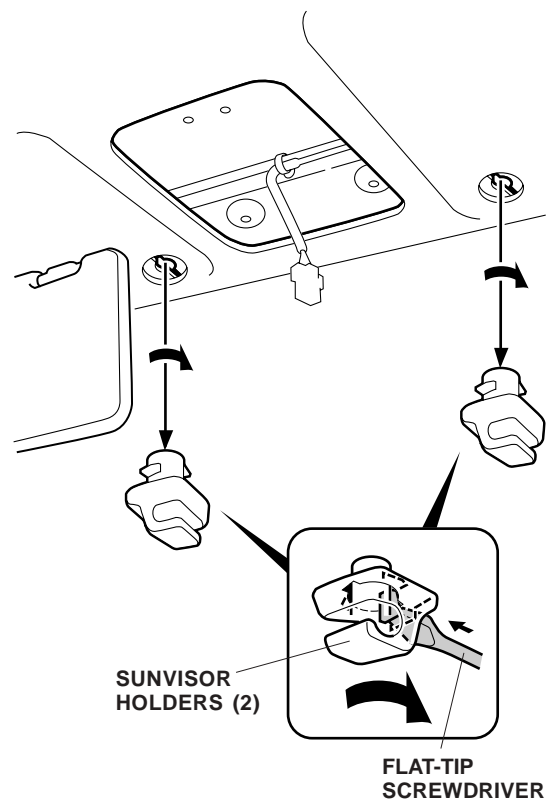

- Remove the cap from the left sunvisor (four retaining tabs).

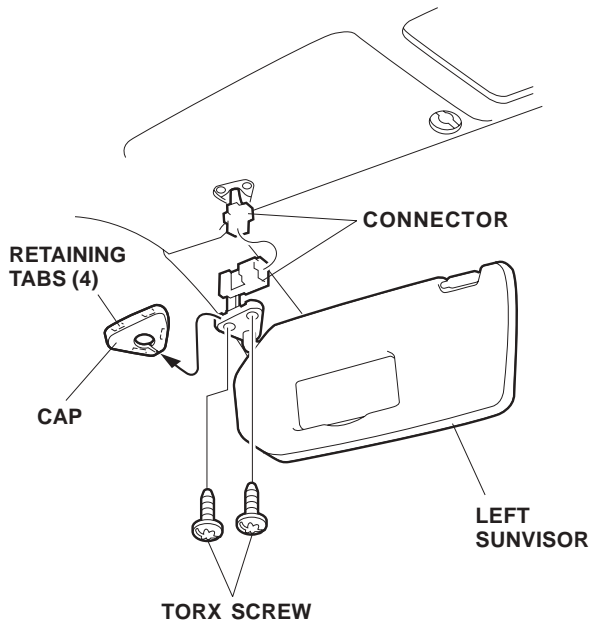

- Remove the left sunvisor (two T25 Torx screws, and unplug the connectors).
- Remove the two caps from the left front grab rail, and remove the grab rail (two screws).

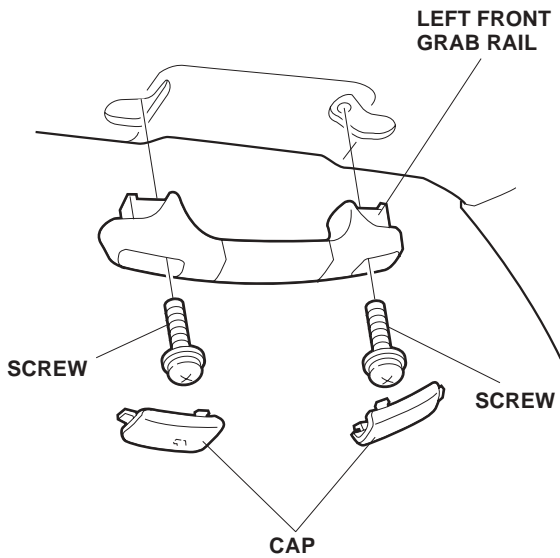

- Remove the fuel lid opener knob, and remove the left front trim (three clips and two retaining tabs).

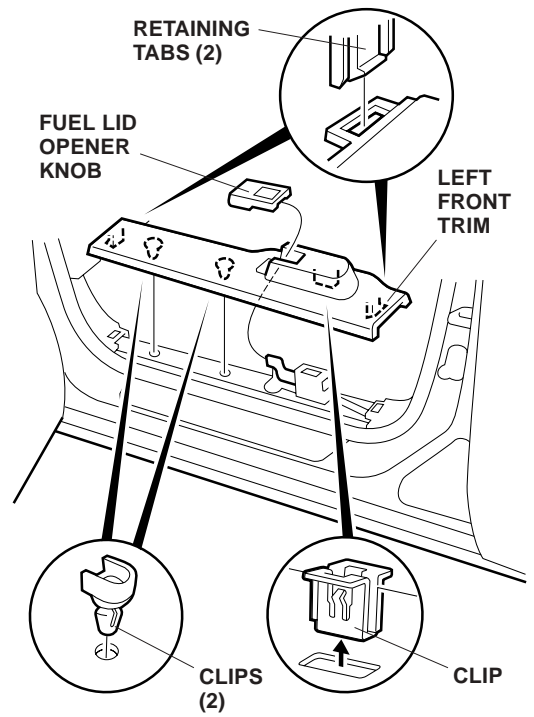

- Remove the weatherstrip from the left kick panel as indicated.

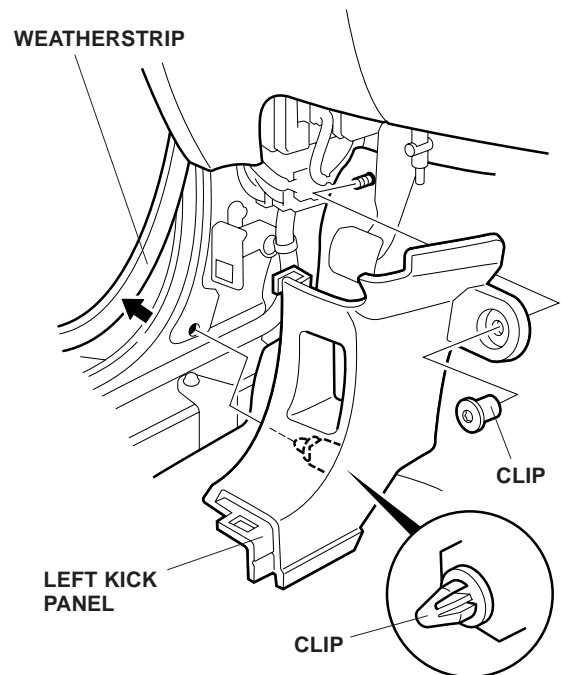

- Remove the left kick panel (two clips).

13. Remove the weatherstrip from the opening edge of the left front door in the area shown, then remove the left front pillar trim (two clips).

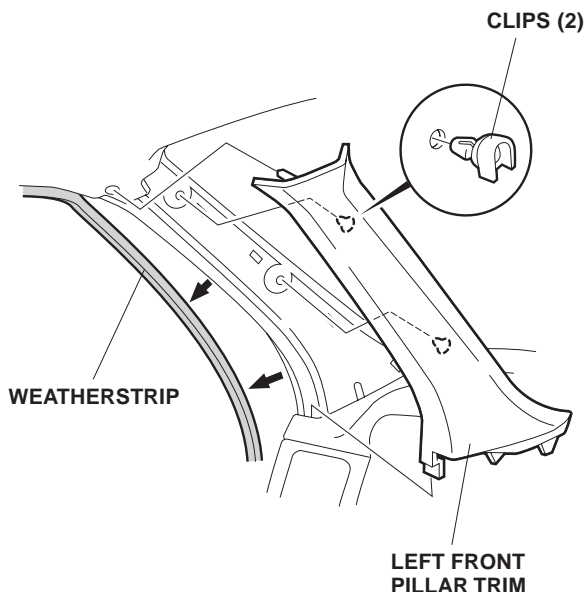

14. Remove the instrument panel side lid (four clips, one retaining tab, and seven hooks).

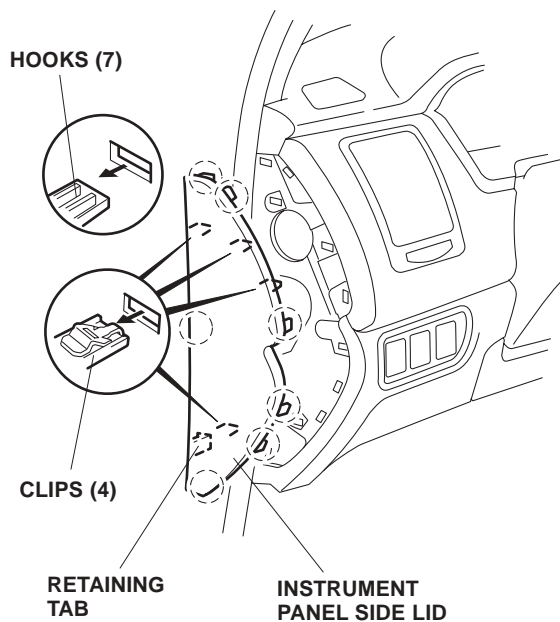

15. Slide the day/night mirror stay onto the mirror holder, then turn the mirror stay counterclockwise as shown.

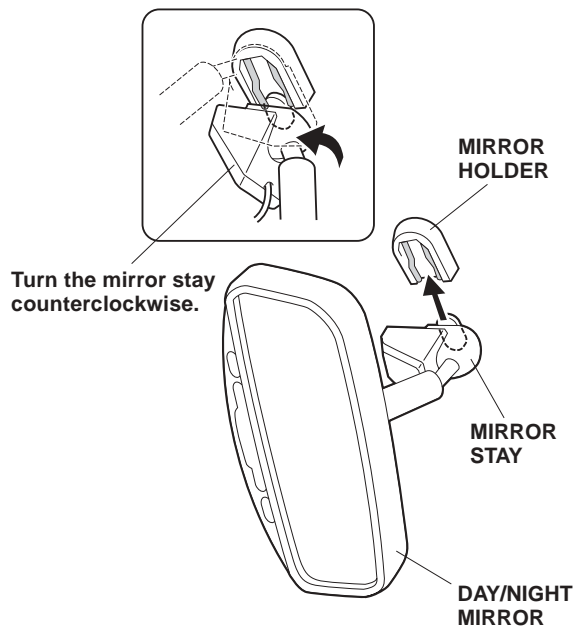

16. Plug the mirror harness 7-pin connector into the rear of the mirror, then route the 3-pin connector up and out through the console opening in the roof lining as shown.

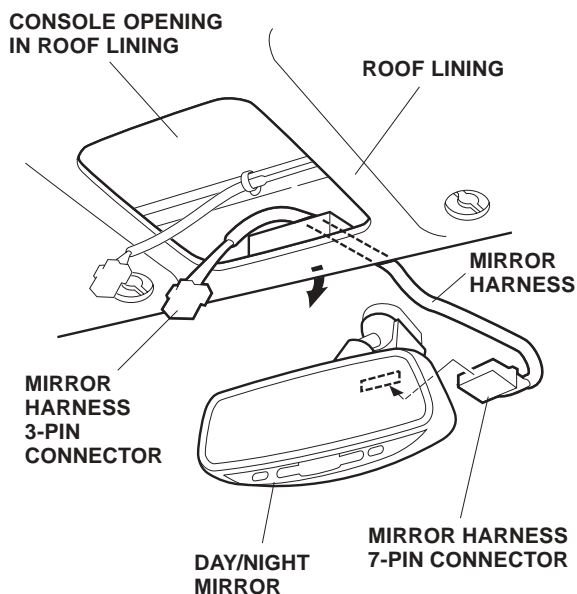

- Slide the end of the upper cover into the lower cover, then route the mirror harness through the grooves of the covers. Attach the lower cover to the stay of the mirror.

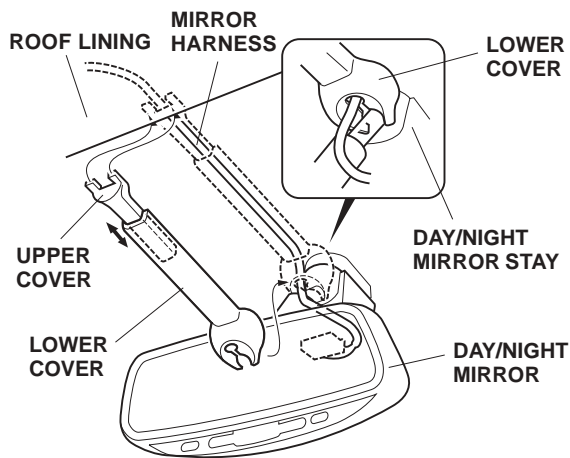

- Slide the upper cover up and under the roof lining as shown.
- Unplug the vehicle 10-pin connector from the fuse box, then unlock the retainer on the 10-pin connector.

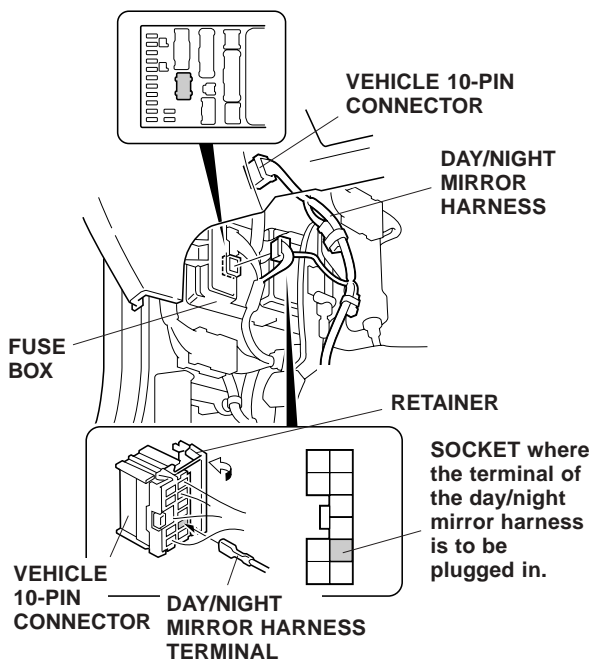

- Carefully push the day/night mirror harness terminal into the vehicle 10-pin connector you just unplugged, then relock the retainer.
- Reconnect the vehicle 10-pin connector to the fuse box.

- Connect the day/night mirror harness 6-pin connector into the 6-pin connector on the fuse box.

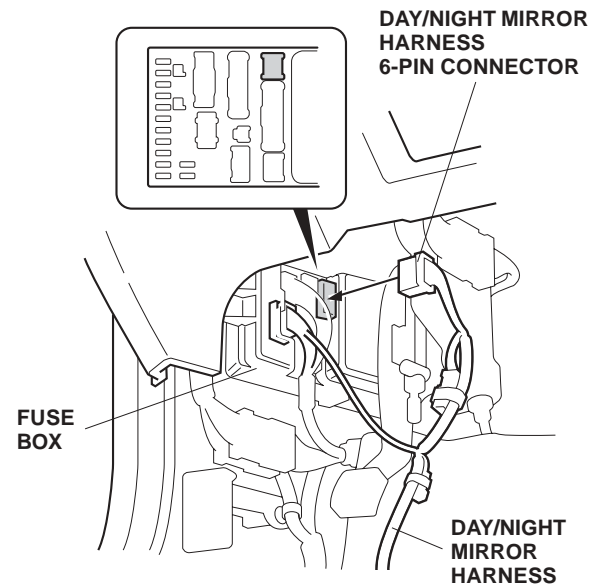

NOTE: If you are also installing the fog lights, remove the dummy connector from the 6-pin connector taped to the day/night mirror harness. Connect the 6-pin connector of the fog light to the 6-pin connector you just unplugged as shown.

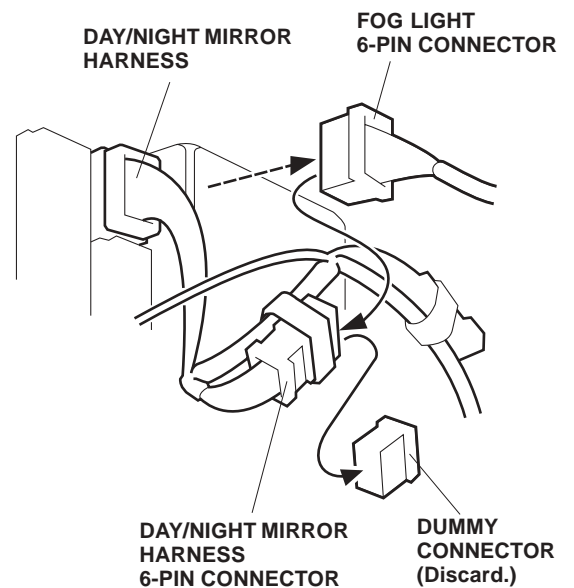

23. Tape a piece of steel wire to the 3-pin connector end of the day/night mirror harness. Pull the end up along the instrument panel side bracket, and out through the clearance between the left front pillar and the instrument panel as shown.

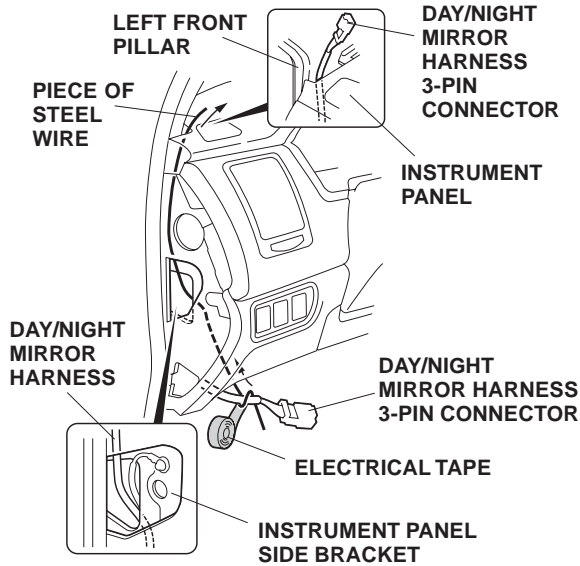

24. Remove the electrical tape and the steel wire from the day/night mirror harness.
25. Route the day/night mirror harness 3-pin connector up along the left front pillar, and out through the roof console opening along the vehicle harness behind the roof lining.

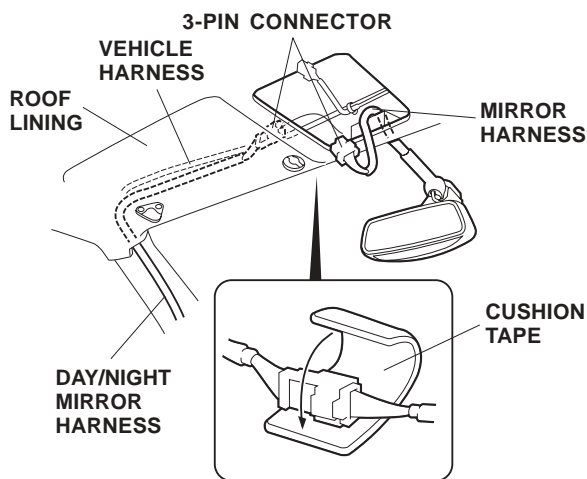

26. Connect the day/night mirror harness 3-pin connector to the 3-pin connector of the mirror harness. Wrap one cushion tape around the connectors.

27. Inside the roof lining, secure the day/night mirror harness and the mirror harness to the vehicle harness with the three wire ties in the areas shown.

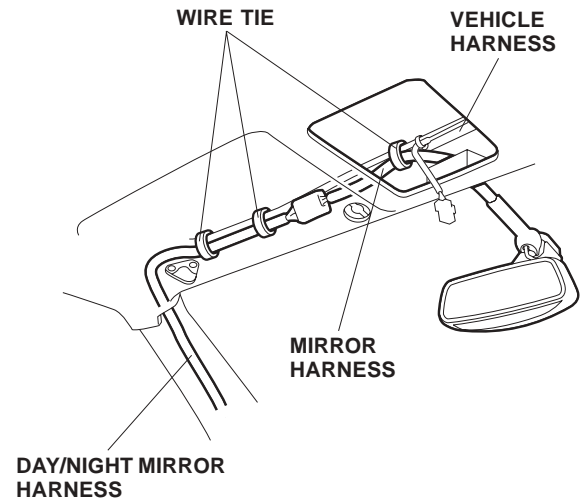

28. **Without RES**; using isopropyl alcohol on a shop towel, thoroughly clean the areas where the cushion tapes will attach. Secure the day/night mirror harness to the left front pillar with three cushion tapes.

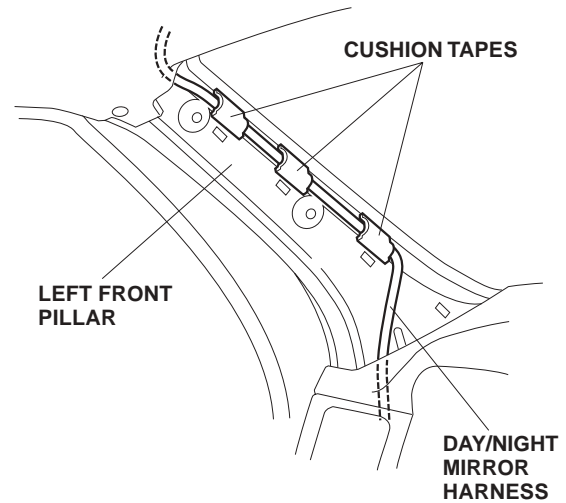

29. **With RES;** after the vehicle harness is routed along the left front pillar, secure the day/night mirror harness to the vehicle harness with three wire ties in the areas shown.

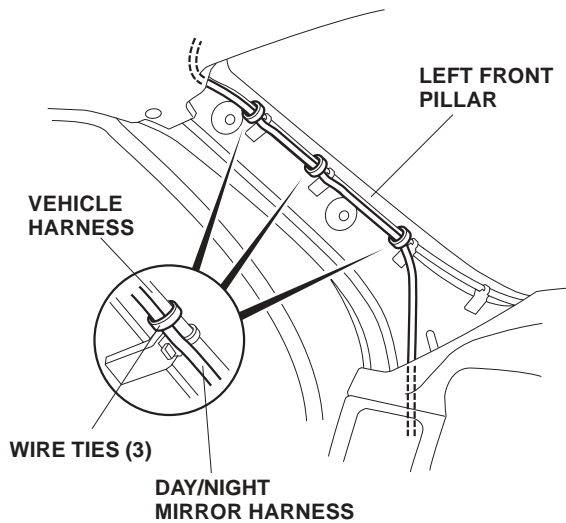

30. Using isopropyl alcohol on a shop towel, clean the area where the cushion tape will attach. Secure the day/night mirror harness to the left front pillar with one cushion tape in the area shown.

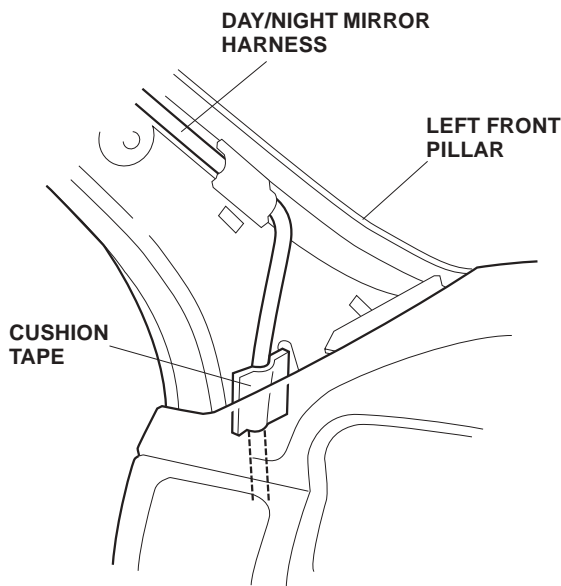

31. Secure the day/night mirror harness to the vehicle harness with three wire ties in the areas shown.

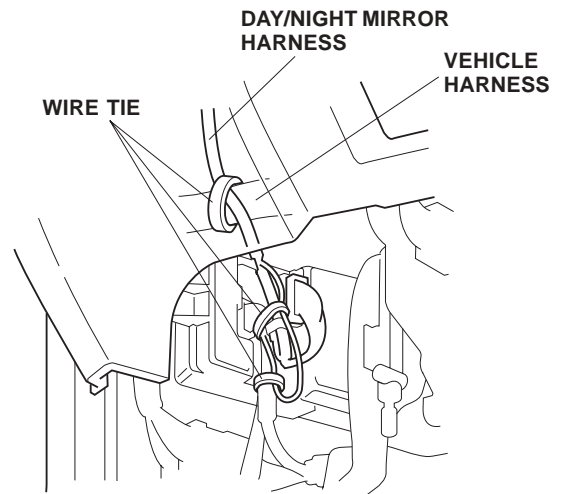

32. Check that all wire harnesses are routed properly and all connectors are plugged in.
33. Reinstall all removed parts. Check that all clips and other fasteners are installed securely.
34. Reconnect the negative cable to the battery.
35. Set the clock, and reset the radio station presets.
36. Check the operation of the automatic day/night mirror according to the Owner's Manual supplied.
- NOTE: Whenever the battery is disconnected, the driver's window AUTO function is disabled.
37. Start the engine. Push down on the driver's window switch until the window is fully open.
38. Pull up on the driver's window switch to close the window completely, then hold the switch for 2 seconds.
39. Test the window AUTO function.
40. Do the PCM idle learn procedure.
- Make sure all electrical items are turned off.
  - Start the engine. Hold the engine speed at 3,000 rpm with no load (in Part of Neutral) until the radiator fans comes on.
  - Let the engine for about 5 inutes with the throttle fully closed and with all electrical items off.

NOTE: If the radiator fan comes on during this step, the time when it is operating must not be included in the 5 minutes.