



# INSTALLATION INSTRUCTIONS

Accessory  
**BUMPER GARNISH,  
FR & RR  
P/N 08F23-S9V-100**

Application  
**PILOT**

Publications No.  
**All 23602**  
Issue Date  
**MAY 2002**

## PARTS LIST

Left front trim piece



Right front trim piece



Left rear trim piece



Right rear trim piece



12 Brackets

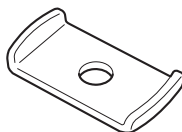

12 Flange nuts



## TOOLS AND SUPPLIES REQUIRED

- Phillips screwdriver
- Flat-tip screwdriver
- Ratchet
- 10 mm Socket
- Drill
- 3 mm and 6 mm Drill bits
- 28 mm Hole saw
- Center punch
- File
- Torque wrench
- Masking tape
- Isopropyl alcohol
- Shop towel

## INSTALLATION

**Customer Information:** The information in this installation instruction is intended for use only by skilled technicians who have the proper tools, equipment, and training to correctly and safely add equipment to your vehicle. These procedures should not be attempted by "do-it-yourselfers."

### NOTE:

- An optional full nose mask cannot be used after the chrome bumper trim pieces are installed.
- Be extremely careful not to damage the body paint finish.
- To prevent damage, rest the front bumper on a blanket during the installation.
- This bumper trim pieces should only be installed if the ambient air temperature is below 60 °F (15 °C) or above.
- To allow the adhesive to "cure," do not wash the vehicle for 24 hours.

### Installing the Front Bumper Trim Pieces

1. Open the hood. Remove the front bulkhead cover (11 clips).

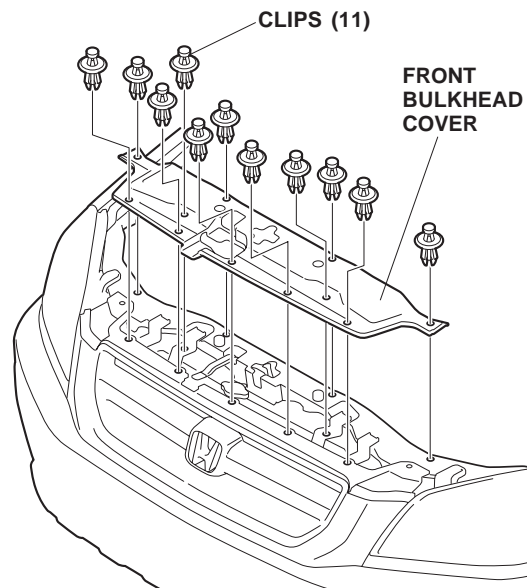

- Remove the two short clips, two self-tapping screws, four bolts and two long clips that secure the front bumper, then remove the front bumper by pulling it out toward you.

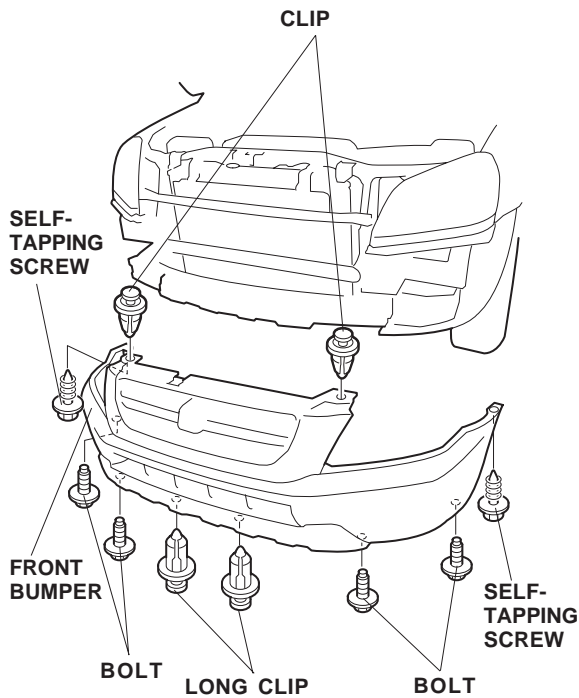

- On the inside of the front bumper, locate the three marks on the left side. Center-punch each of the three marks.

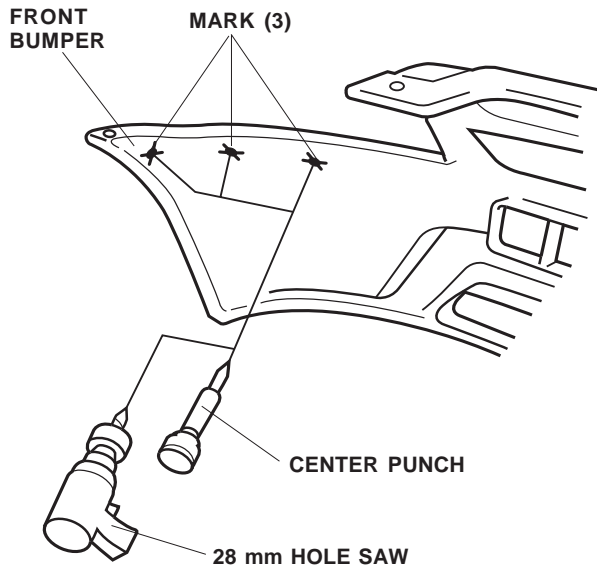

- While wearing eye protection, drill a 28 mm hole through each of the center-punched marks. Remove any burrs from the edges of the holes.

- Place the left front trim piece on the front bumper, and adjust it until it fits snug. Using strips of masking tape, mark the location of the trim piece.

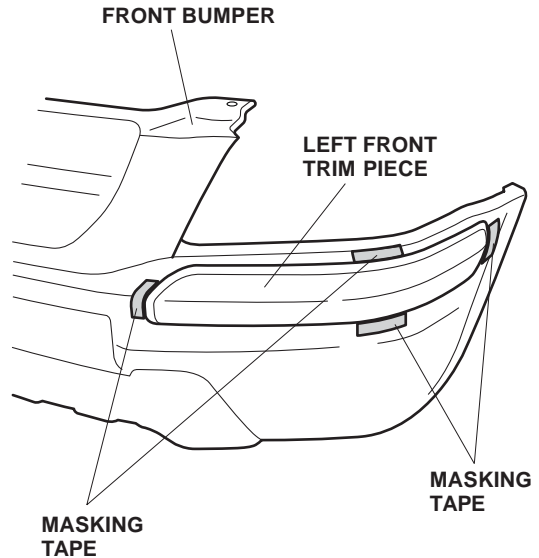

- Attach a strip of masking tape to the ends of the three adhesive backings shown, and remove 2 to 3 inches from the ends. Fold the ends up and tape them to the front of the trim piece. Remove the remaining three adhesive backings.

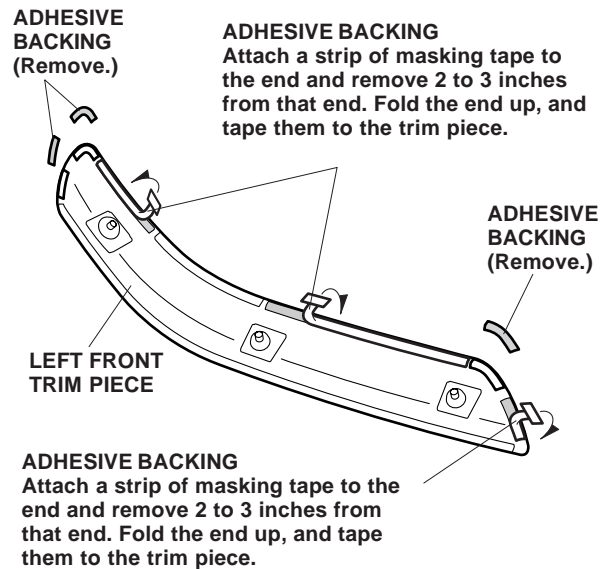

- Using isopropyl alcohol on a shop towel, clean the area where the trim piece will attach.

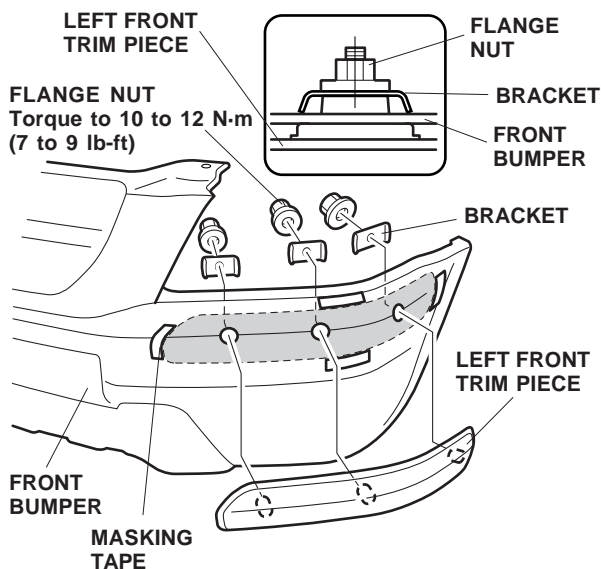

- Position the left front trim piece on the front bumper and align the edges with the masking tape. Install one bracket and one flange nut over each stud from the trim piece. Note the direction of the brackets.
- Torque the flange nuts to 10 to 12 N·m (7 to 9 lb-ft).
- While holding light pressure on the left front trim piece, slowly and carefully remove the adhesive backings.

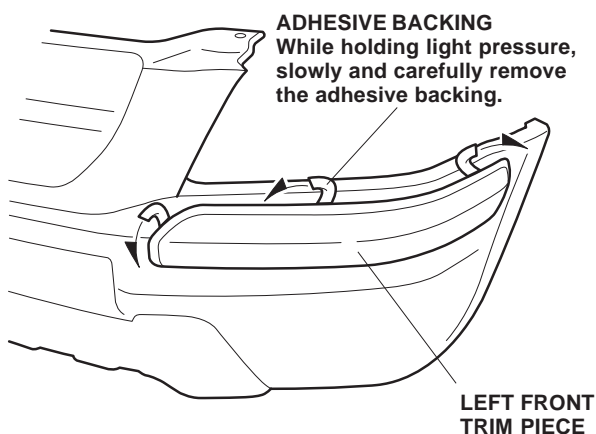

- Repeat steps 3 through 10 to install the trim piece on the right side of the bumper.
- Reinstall the front bumper, and the front bulkhead cover.

### Installing the Rear Bumper Trim Piece

- Remove the two short self-tapping washer-screws, four self-tapping screws, two long self-tapping washer-screws, two washer-screws, four clips and five bolts that secure the rear bumper. Slide the rear bumper out to release the two fender clips. Set the bumper on a blanket.

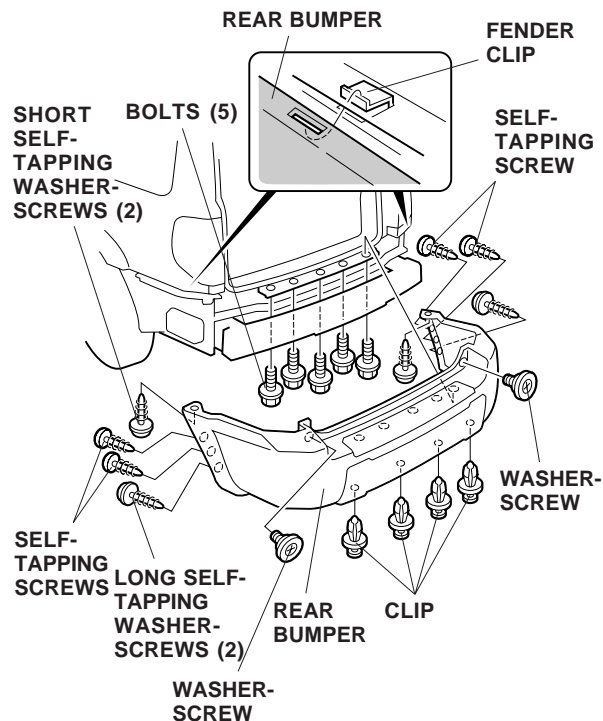

- On the inside of the rear bumper, locate the three marks on the left side. Center-punch each of the three marks.

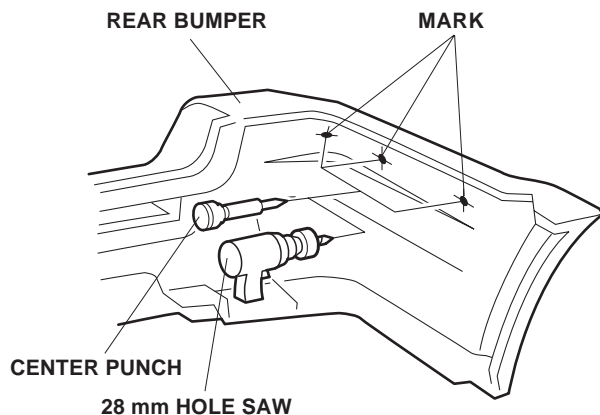

- While wearing eye protection, drill a 28 mm hole through each of the center-punched marks. Remove all burrs from the edges of the holes.

- Position the left rear trim piece on the rear bumper and adjust it until it fits snugly. Using strips of masking tape, mark the location of the trim piece.

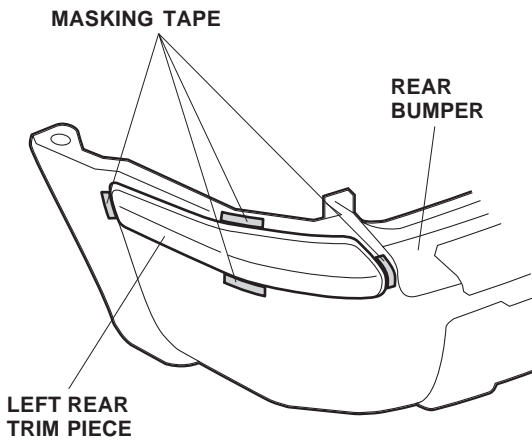

- Attach a strip of masking tape to the ends of the adhesive backings shown and remove 5 to 6 inches from the ends. Fold the ends up and tape them to the front of the trim piece. Remove the remaining adhesive backing.

**ADHESIVE BACKING**  
Attach a strip of masking tape to the end, and remove 5 to 6 inches from that end. Fold the end up and tape them to the front of the trim piece.

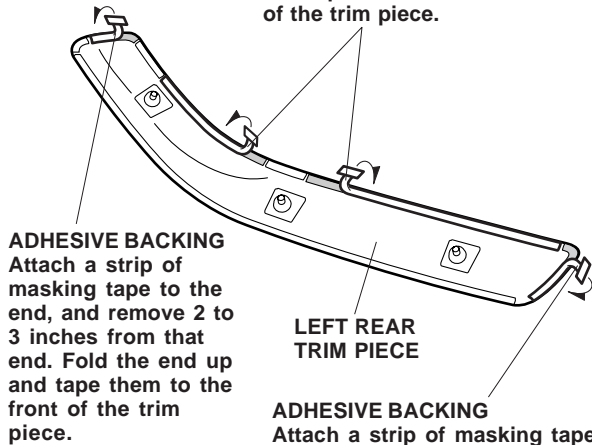

**ADHESIVE BACKING**  
Attach a strip of masking tape to the end, and remove 2 to 3 inches from that end. Fold the end up and tape them to the front of the trim piece.

**ADHESIVE BACKING**  
Attach a strip of masking tape to the end, and remove 2 to 3 inches from that end. Fold the end up and tape them to the front of the trim piece.

- Using isopropyl alcohol on a shop towel, clean the area where the trim piece will attach.
- Position the left rear trim piece on the rear bumper, and align it with the masking tape. Install one bracket and one flange nut over each stud from the trim piece. Note the direction of the brackets.

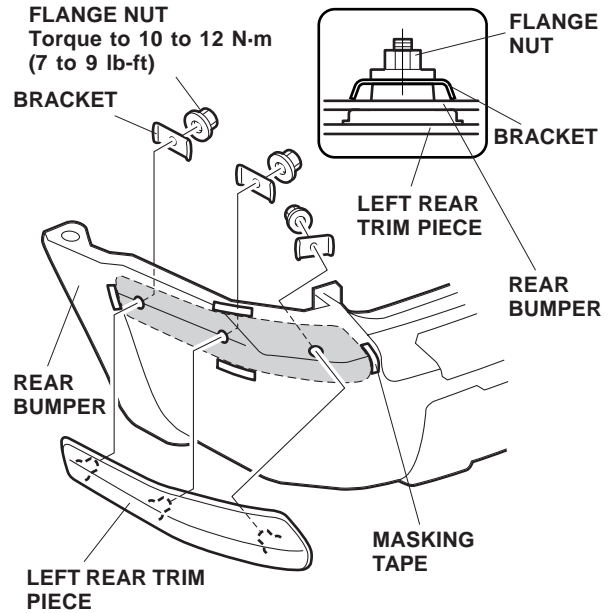

- Torque the flange nuts to 10 to 12 N·m (7 to 9 lb-ft).
- While holding light pressure on the trim piece, slowly and carefully remove the adhesive backings.

**ADHESIVE BACKING**  
While holding light pressure on the trim piece, slowly and carefully remove the adhesive backings.

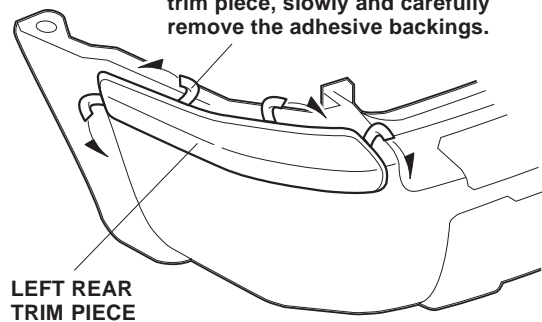

- Repeat steps 14 through 21 to install the trim piece on the right side of the bumper.
- Reinstall the rear bumper.
- Remove all of the masking tape.