



INSTALLATION INSTRUCTIONS

Accessory	Application	Publications No.
DOOR VISOR	PILOT	All 25852
		Issue Date
		AUG 2003

PARTS LIST

Door visor (Front left)

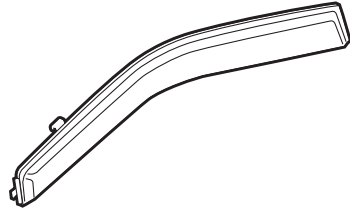

Door visor (Front right)

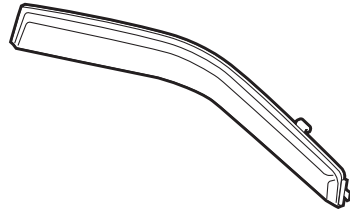

Door visor (Rear left)



Door visor (Rear right)



4 EPT sealers

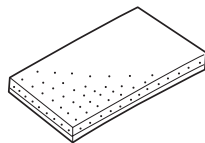

TOOLS REQUIRED

- Isopropyl alcohol
- Shop towel
- Masking tape

INSTALLATION

NOTE:

- These instructions show the left door visors being installed. The same procedure applies to installing the right door visors.
- Be careful not to damage the paint finish and glass run channels when installing the door visors.
- Handle the door visors with care. They are not designed to absorb shock or impact.
- This door visor kit should only be installed if the ambient air temperature is 60°F (15°C) or above.
- To allow the adhesive to “cure”, do not wash the vehicle for 24 hours.

Installing the Front Door Visor

1. Lower the front door glass completely. Remove the door glass run channel from the door sash in the area shown.

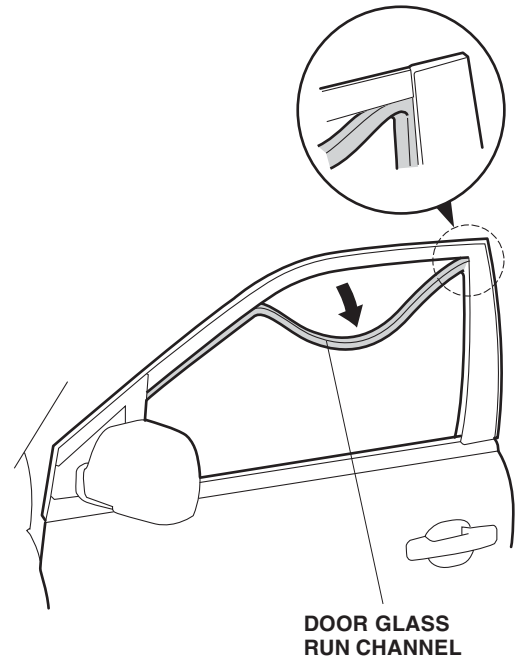

- Using isopropyl alcohol on a shop towel, clean the shaded area of the door sash.

BONDING SURFACE
(Clean with isopropyl alcohol.)

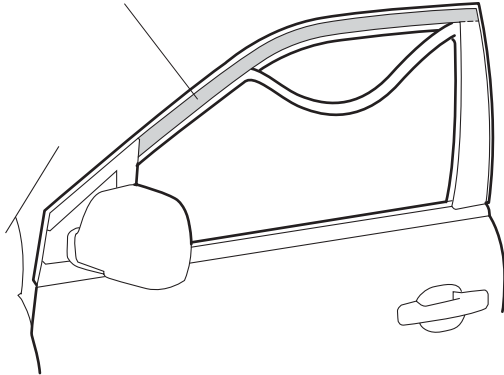

- Remove the adhesive backing from the EPT sealer and attach the EPT sealer to the door sash as shown.

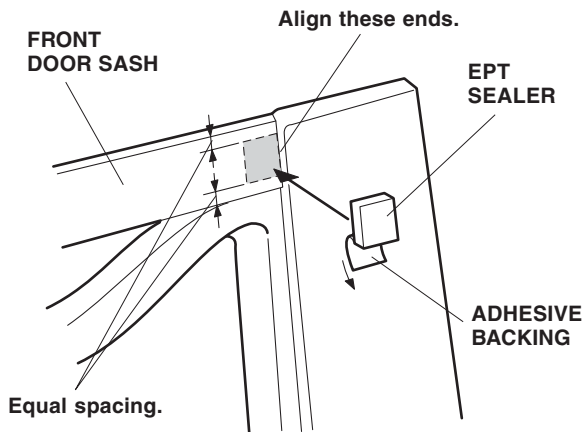

- Attach a strip of masking tape to the end of the adhesive backing at the front of the door visor, and remove 2 to 3 inches from the end. Fold back the end and tape the end to the back of the door visor.

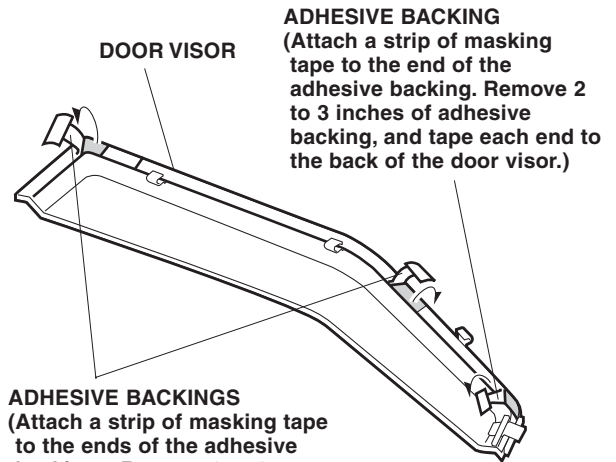

ADHESIVE BACKINGS
(Attach a strip of masking tape to the ends of the adhesive backings. Remove 2 to 3 inches of adhesive backing, and tape each end to the front of the door visor.)

- Attach a strip of masking tape to the ends of the remaining adhesive backings, and remove 2 to 3 inches from the ends. Fold back the ends and tape the ends to the front of the door visor. Note the direction of the adhesive backings.

- Attach the front bracket of the door visor to the door sash, and push the two rear brackets on the door sash. Insert the front tab under the door mirror base.

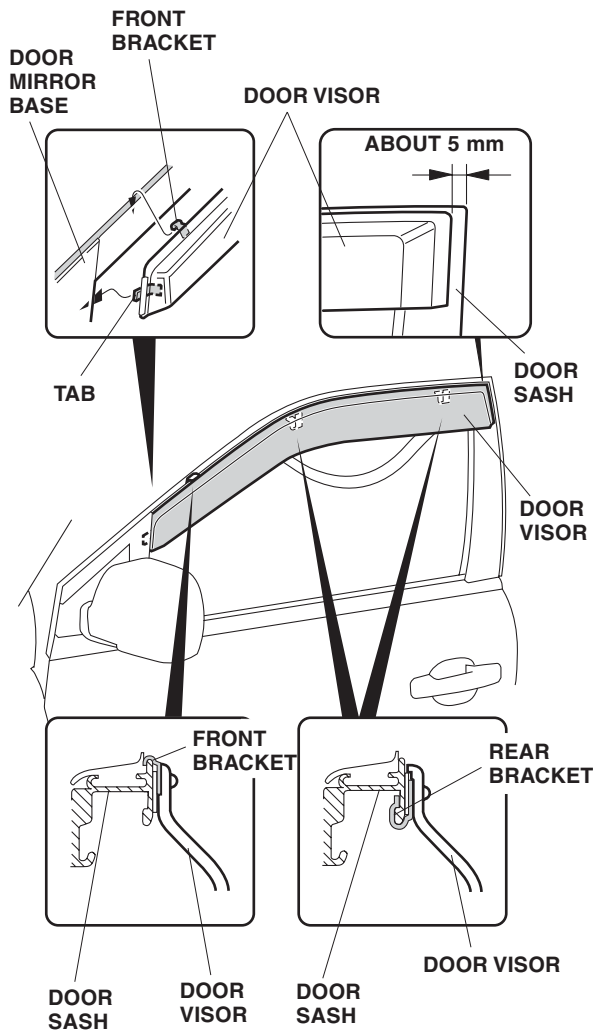

- Adjust the location of the door visor so that the clearance between the door visor and door sash is about 5 mm at the back. There should be no clearance between the front tab and the visor.

- While holding light pressure on the door visor, carefully remove the adhesive backing in the directions shown. Using the palm of your hand, hold the door visor firmly against the door for 30 seconds or more.

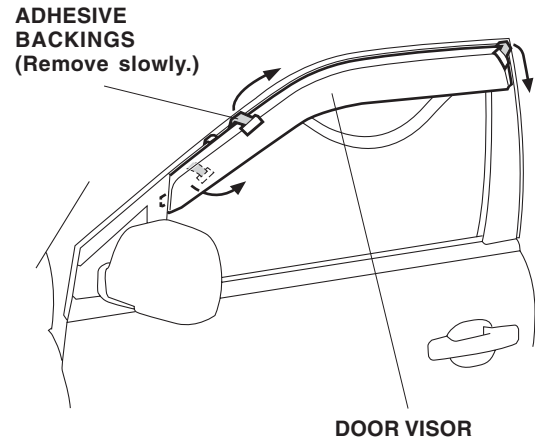

- Reinstall the door glass run channel. Make sure the run channel is seated properly on the rear brackets.

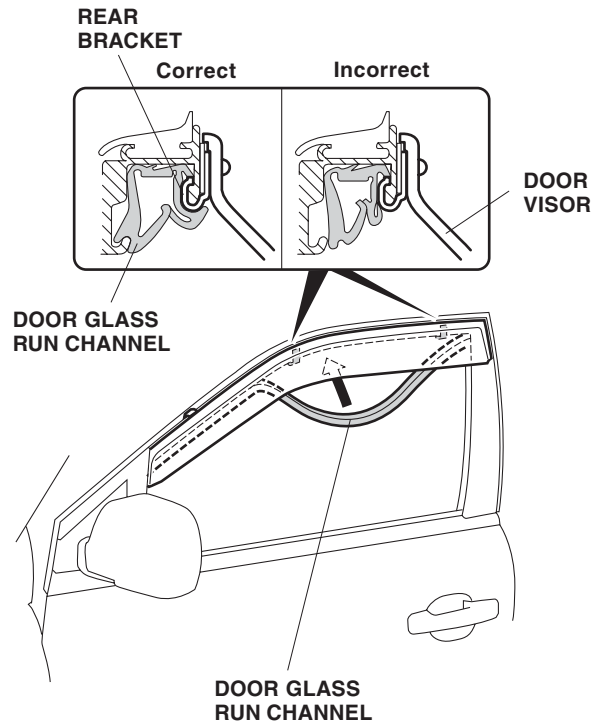

Installing the Rear Door Visor

10. Lower the rear door glass completely. Remove the door glass run channel from the door sash in the areas shown.

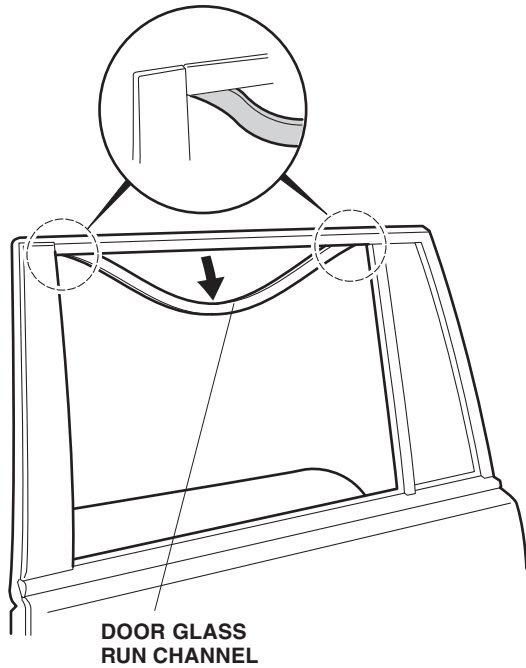

11. Using isopropyl alcohol on a shop towel, clean the shaded area of the door sash.

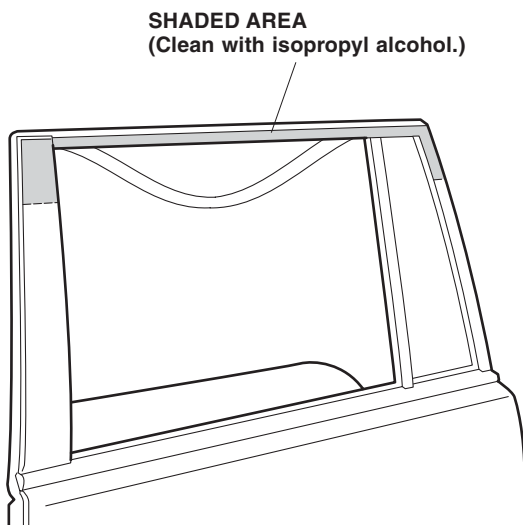

12. Remove the adhesive backing from the EPT sealer and attach the EPT sealer to the door sash as shown.

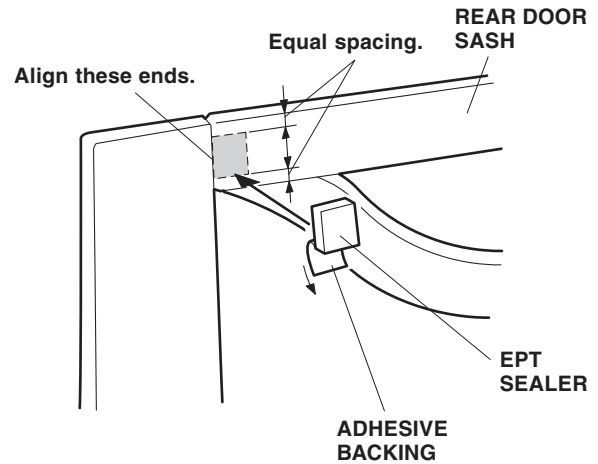

13. Attach a strip of masking tape to the end of the adhesive backing at the rear of the door visor, and remove 2 to 3 inches from the end. Fold back the end and tape the end to the back of the door visor.

ADHESIVE BACKING
(Attach a strip of masking tape to the end of the adhesive backing. Remove 2 to 3 inches of adhesive backing, and tape each end to the back of the door visor.)

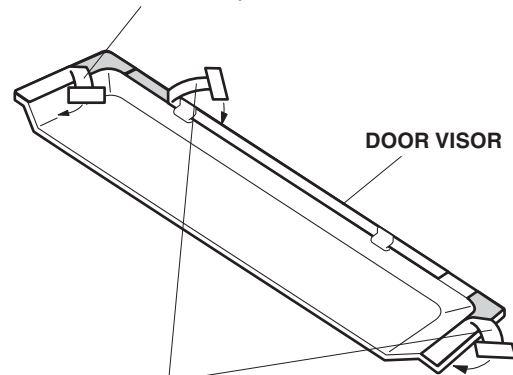

ADHESIVE BACKINGS
(Attach a strip of masking tape to the ends of the adhesive backings. Remove 2 to 3 inches of adhesive backing, and tape each end to the front of the door visor.)

14. Attach a strip of masking tape to the ends of the remaining adhesive backings, and remove 2 to 3 inches of adhesive backings. Fold back the ends, and tape the ends to the front of the door visor.

15. Attach the rear bracket of the door visor to the door sash, and push the two brackets on the door visor.

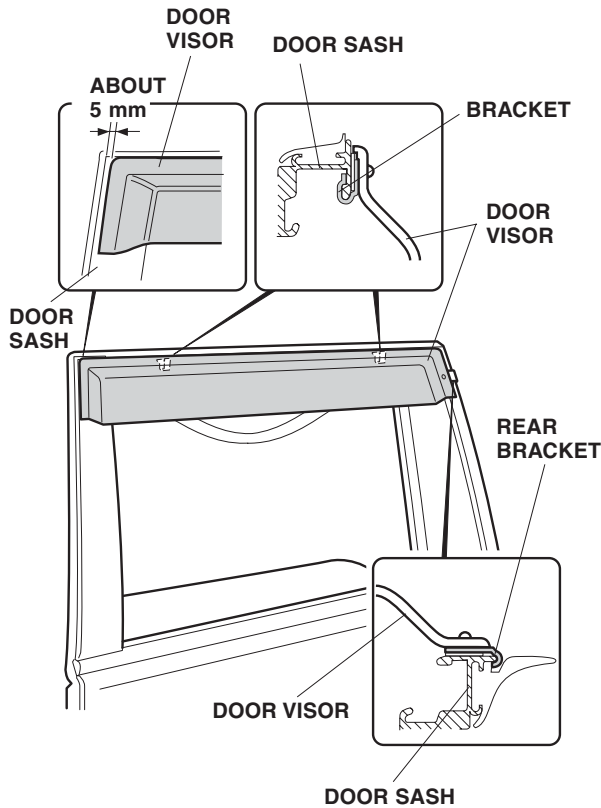

16. Adjust the location of the door visor so that the clearance between the door visor and door sash is about 5 mm at the top.

17. While holding light pressure on the door visor, carefully remove the adhesive backing in the directions shown. Using the palm of your hand, hold the door visor firmly against the door for 30 seconds or more.

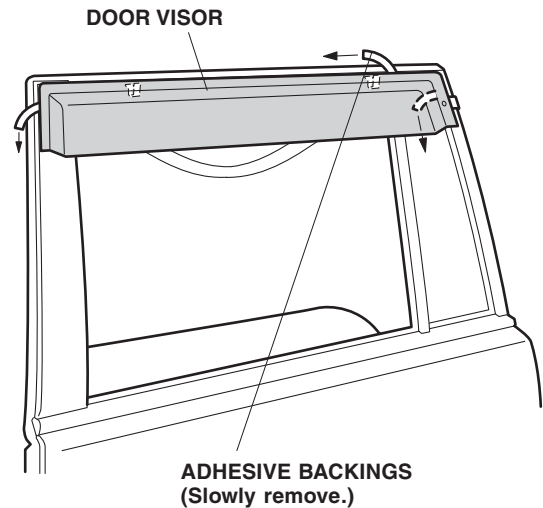

18. Reinstall the door glass run channel. Make sure the run channel is seated properly on the rear brackets.

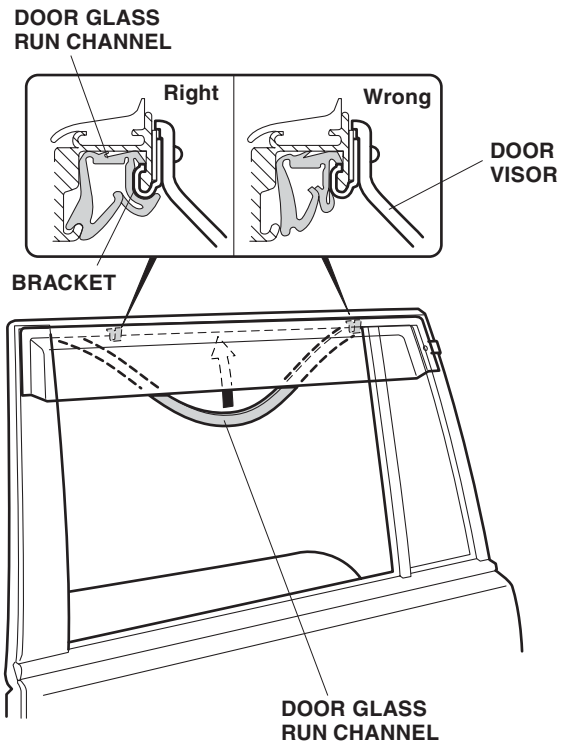

19. Repeat steps 1 through 18 to install the door visors on the right side of the vehicle.
20. Raise and lower all the windows several times to seat the glass run channels.

INSPECTION

Release and reset the power window anti-pinch system.

To release:

1. Turn the ignition switch OFF.
2. Remove the driver's side power window 20A fuse from the fuse box.
3. Turn the ignition switch ON (II) and continue to hold the switch for one second. Turn the ignition switch OFF and reinstall the 20A fuse after 5 seconds.
4. Again turn the ignition switch ON (II) and make sure that the AUTO feature does not work.

To reset:

1. Check that the door and door glass related parts are installed properly.
2. Start the engine.
3. Push down on the DOWN end of the driver's window switch until the window is fully open.
4. Pull back on the UP end of the driver's window switch until the window is fully closed and continue to hold the switch for 2 seconds or more.
5. Make sure that the AUTO feature works correctly. If not, repeat step 1 through 4.

USE AND CARE

- To clean the door visor, wipe it with a soft cloth dampened with clean water.
- To remove dust and dirt, clean with a solution of liquid dishwashing soap and water using a soft cloth or chamois. Never use organic solvents such as thinner, benzine, alcohol, etc., or cleaners containing abrasive compounds.