



INSTALLATION INSTRUCTIONS

Accessory
IN-VEHICLE ENTERTAINMENT SYSTEM (DVD BASED)

Application
PILOT

Publications No.
All 23621
Issue Date
OCT 2002

PARTS LIST

**DVD Monitor Kit
P/N 08B23-S9V-100**

Template

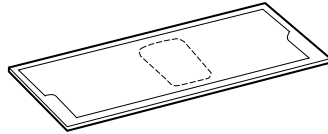

Monitor bracket

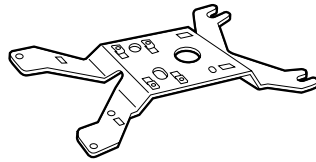

Monitor trim ring

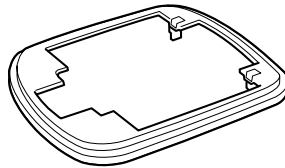

2 Cushion tapes

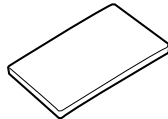

4 Washer bolts, 6 x 12 mm



***i*-VES DVD Base Unit Kit
P/N 08A23-9E1-010**

DVD player

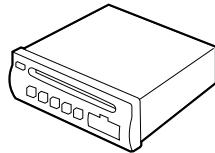

FM modulator

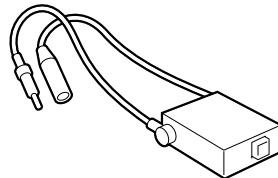

i-VES harness

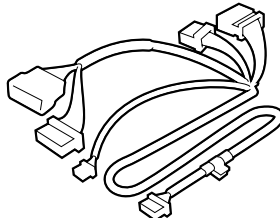

Monitor console

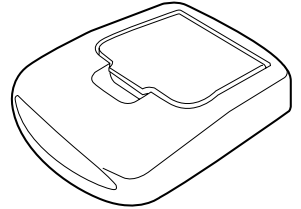

2 Headphones



Remote control

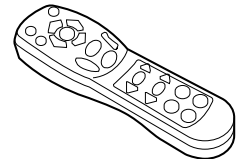

Cushion tape

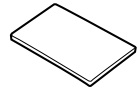

4 Self-tapping screws, 4 x 19 mm



10 Wire ties

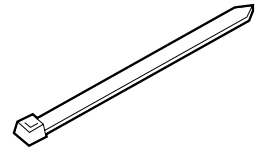

4 Washer bolts, 5 x 12 mm



Owner's Manual

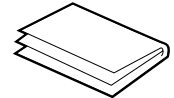

**DVD DIN Bezel Kit
P/N 08B23-S9V-100A**

DIN bezel

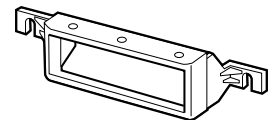

TOOLS AND SUPPLIED REQUIRED

Phillips screwdriver
Flat-tip screwdriver
Ratchet
10 mm and 14 mm sockets
Torx wrench
Utility knife
Masking tape
Electrical tape
Shop towel
Piece of wire
Felt-tip pen
Isopropyl alcohol
Scissors
Tape measure

Illustration of *i*-VES Installed on the Vehicle

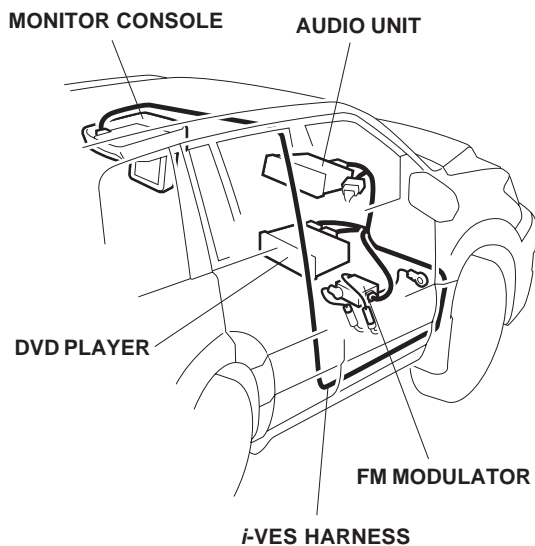

INSTALLATION

Customer Information: The information in this installation instruction is intended for use only by skilled technicians who have the proper tools, equipment, and training to correctly and safely add equipment to your vehicle. These procedures should not be attempted by "do-it-yourselfers."

1. Make sure you have the anti-theft code for the radio, then write down the frequencies for the preset buttons.
2. Disconnect the negative cable from the battery.

Cutting the Headliner

3. Using scissors, cut out the marked areas from the template along the line. Position the template on the headliner and align it with the left and right grab rails of the second seat, then tape the template to the headliner using strips of masking tape.

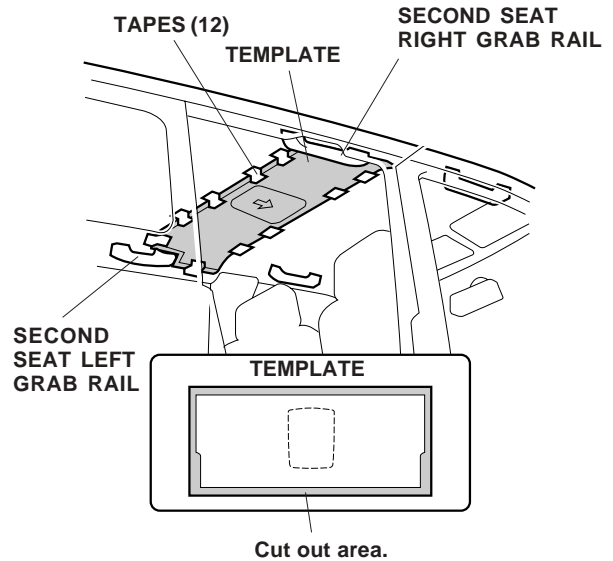

4. Using a utility knife, cut out the marked area from the template along with the headliner as shown.

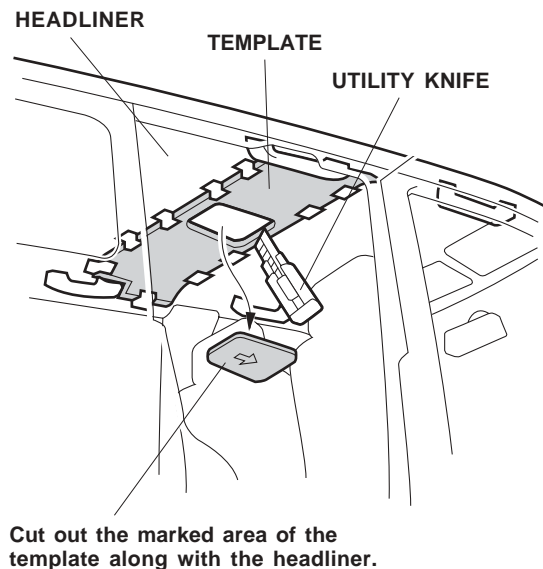

5. Release the four clips, and remove the front passenger's seat rear frame cover.

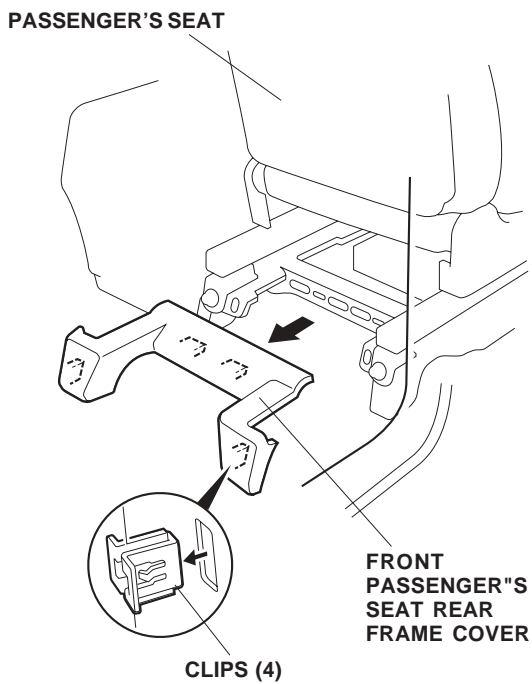

6. Release the four clips, and remove the front passenger's seat front frame cover.

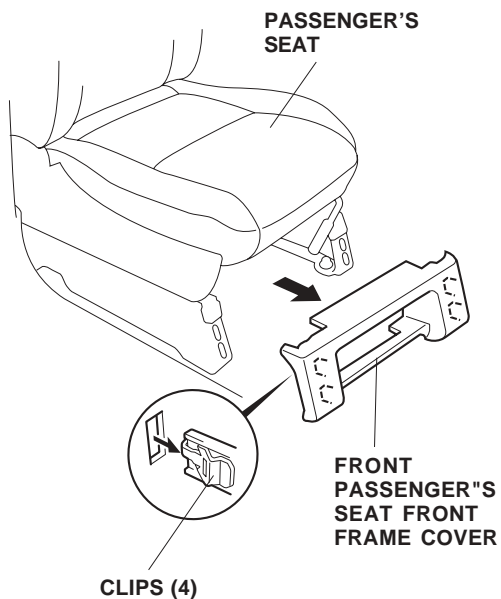

7. Remove the four bolts that secure the passenger's seat side rail to the floor.

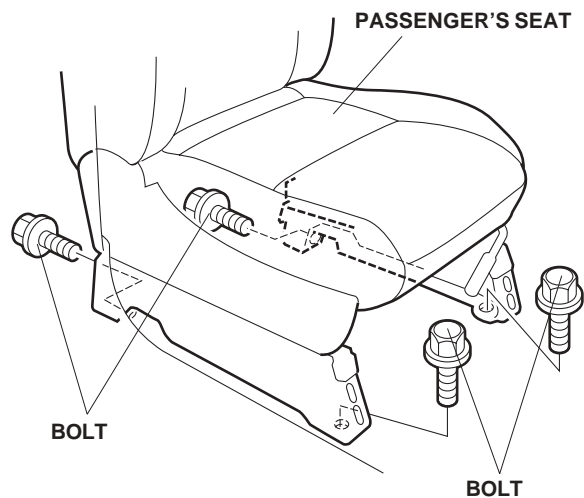

8. Move the passenger's seat back and out of way.
9. Remove the center console lower cover (seven clips).

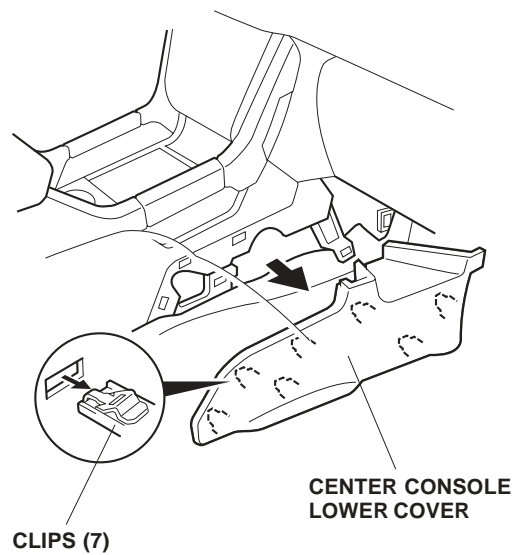

- Using a flat-tip screwdriver wrapped with a shop towel, gently pry out on the audio panel to remove the five clips. Unplug the vehicle connectors and remove the audio panel.

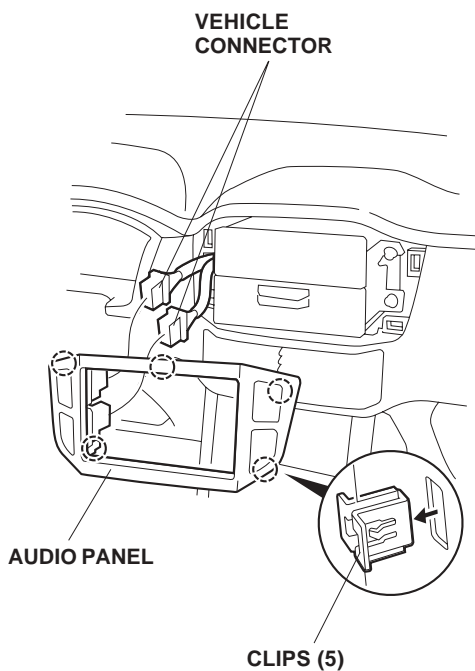

- Remove the audio unit (four screws, pull the audio unit out toward you, unplug the vehicle connector and antenna lead).

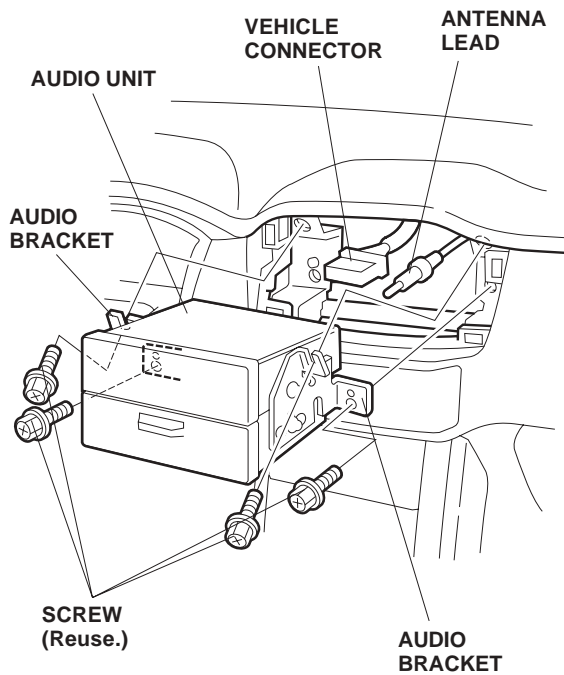

- Remove the driver's and passenger's center console trim pieces (three clips each). Take care not to damage the clips.

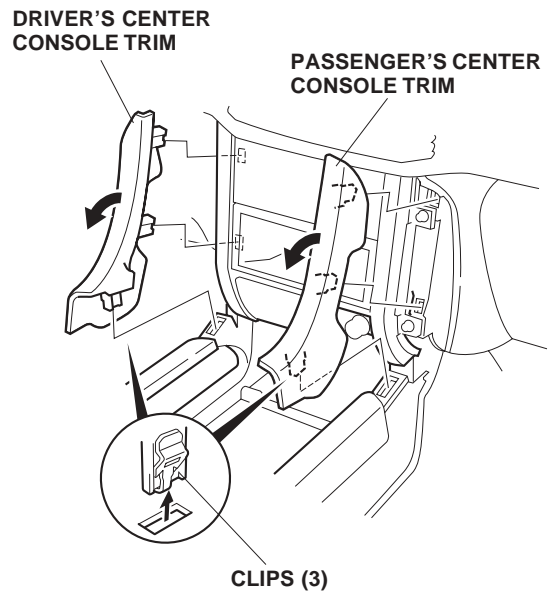

- Remove four self-tapping screws that fasten the center panel.

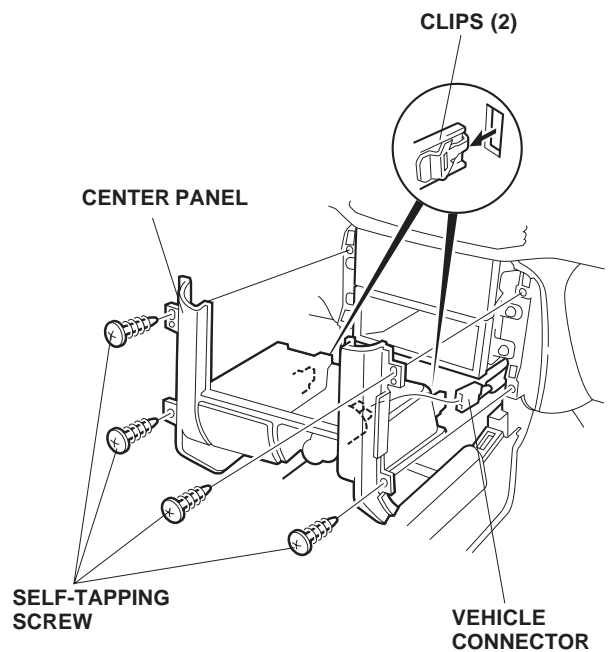

- Pull the center panel out toward you to release the two clips. Unplug the vehicle connector from the accessory socket, and remove the center panel.

- Remove four screws that fasten the left and right vehicle brackets. Pull the heater control unit and pocket out toward you, and unplug the vehicle connectors.

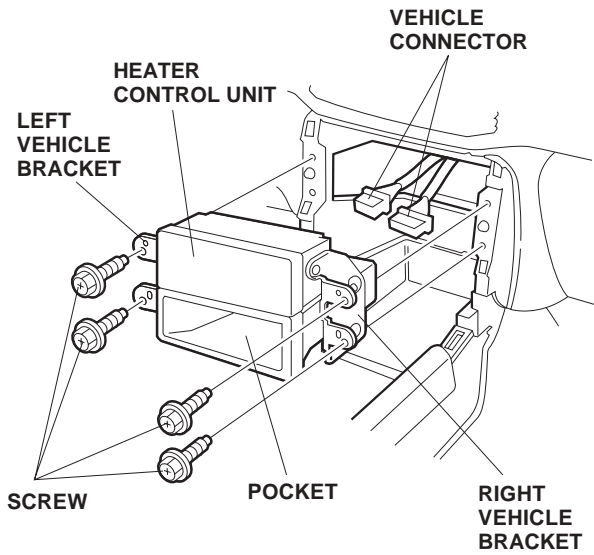

- Pry up on the two retaining tabs and three clips, and remove the right front door sill.

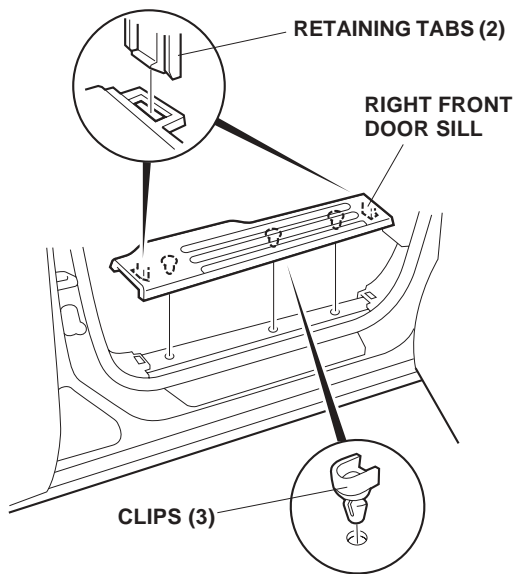

- Remove the door weatherstrip. Remove the right kick panel by removing the screw clip and pulling it out toward you to release the clip, and then back to release two retaining tabs.

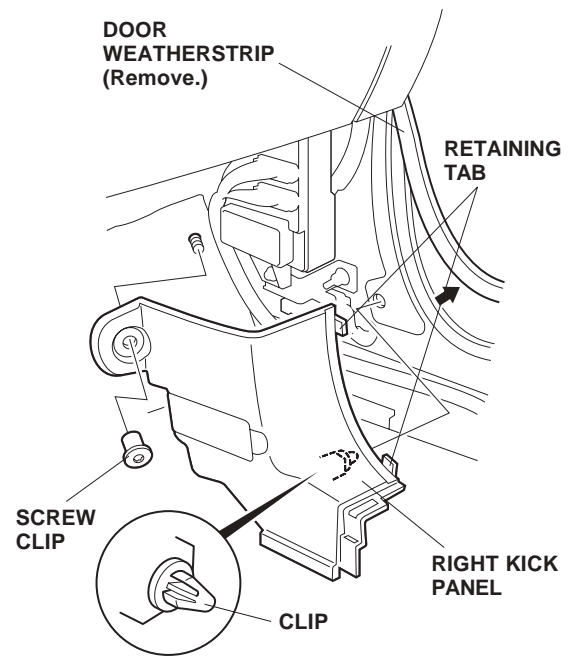

- Lower the glove box by removing the right and left stops.

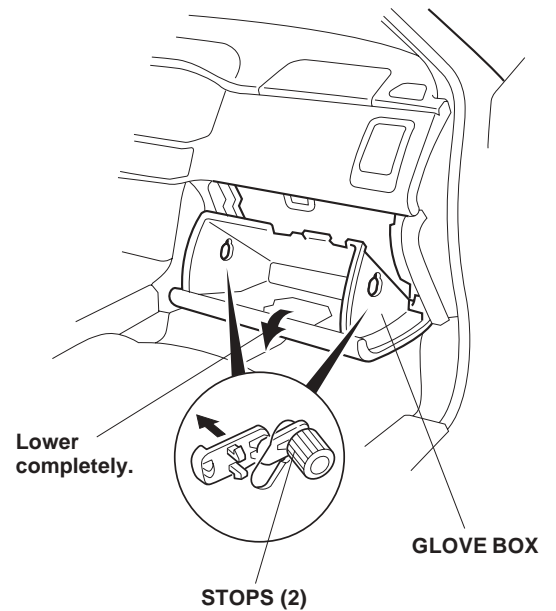

19. Remove the door weatherstrip from around the right rear door sill. Pry up on two retaining tabs and three clips, and remove the right rear door sill.

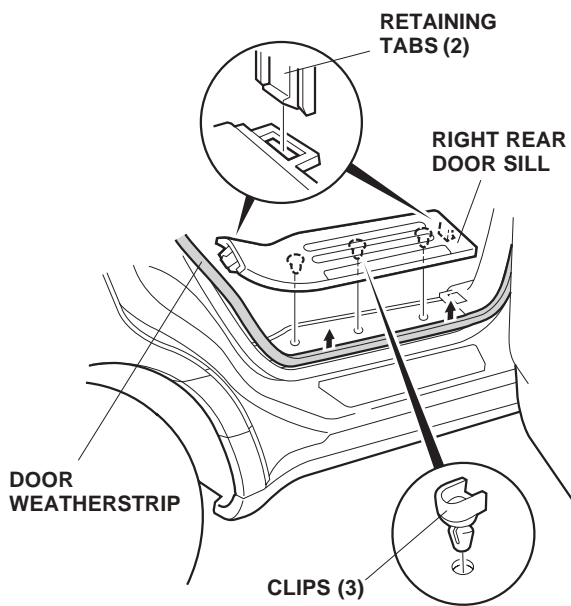

20. Remove the 14 mm center pillar anchor bolt.

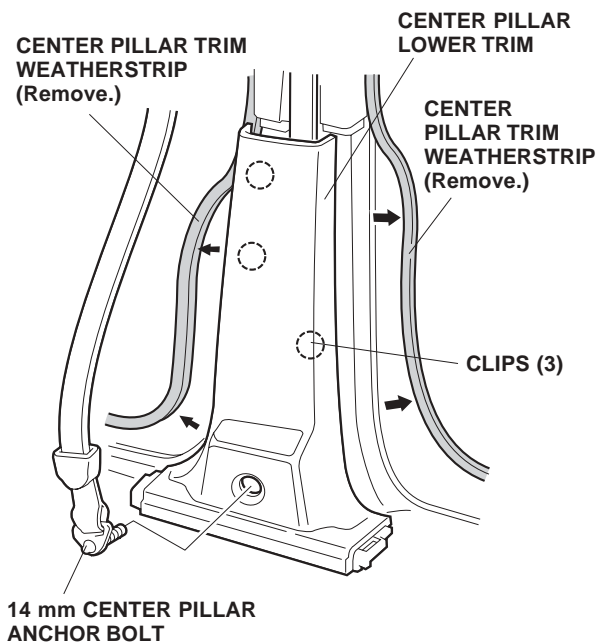

21. Remove the center pillar trim weatherstrip. Pull the center pillar lower trim out toward you to release the three clips, and remove the trim.

22. Release the three retaining tabs that secure the center pillar upper anchor cover, and remove the anchor cover.

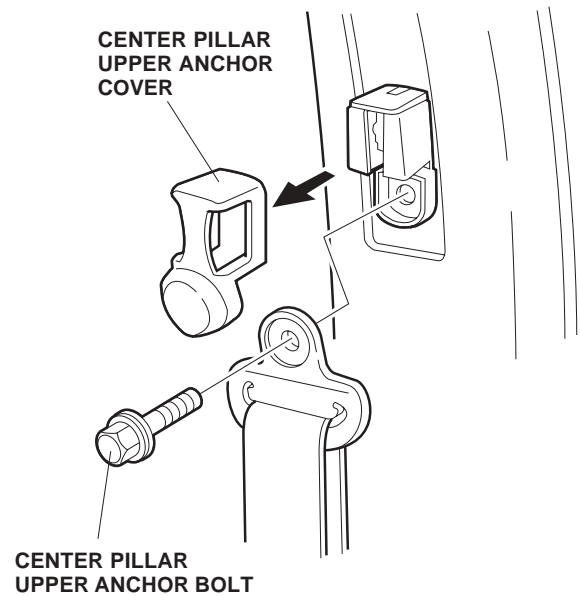

23. Remove the center pillar upper anchor bolt.

24. Remove the center pillar upper trim by pulling it out toward you to release the clip.

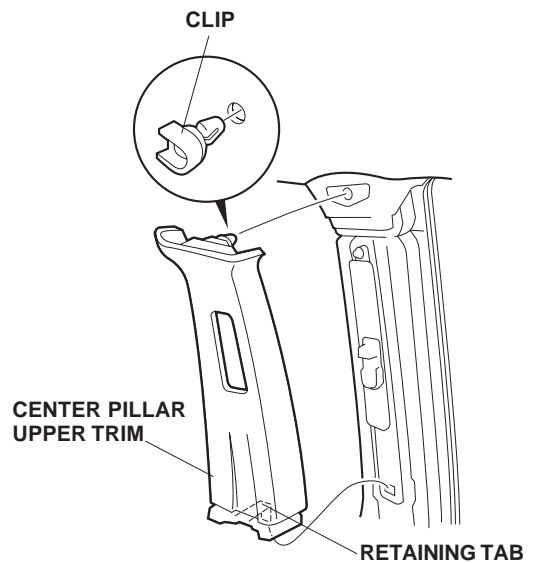

25. Remove the lens from the roof console (four retaining tabs).

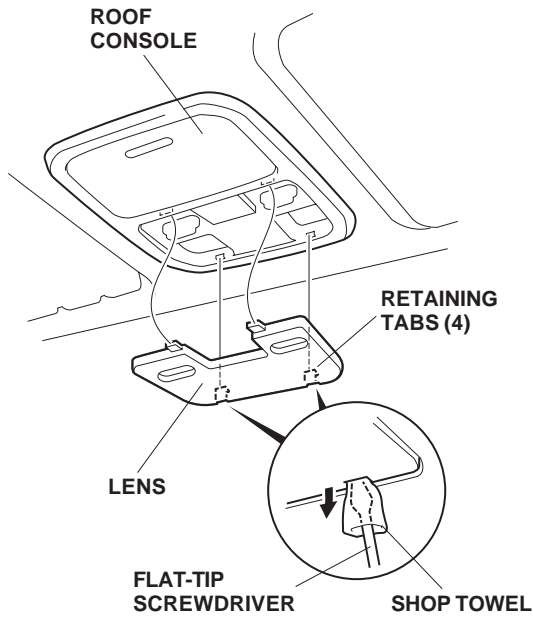

26. Remove the roof console (four screws and unplug the connector).

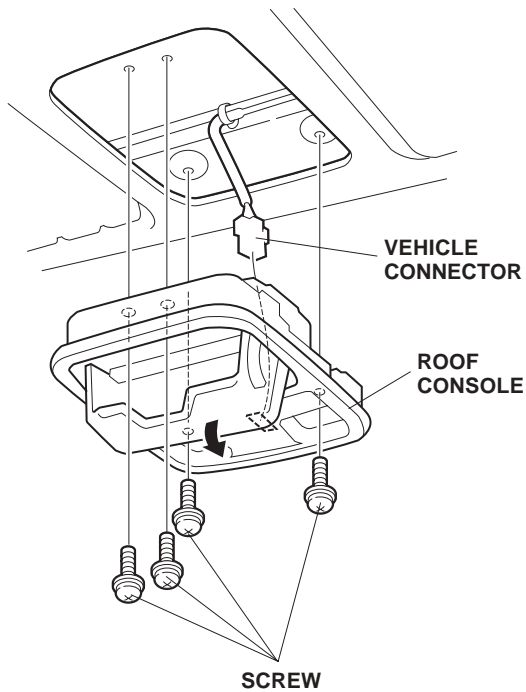

27. Remove the cap from the right sun visor (four retaining tabs).

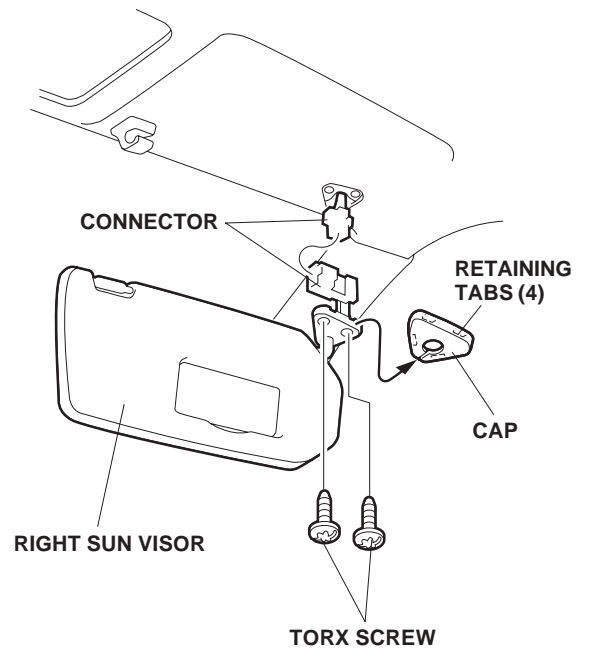

28. Remove the right sun visor (two Torx screws and unplug the connector).

29. Remove the two caps from the right front grab rail and remove the grab rail (two screws).

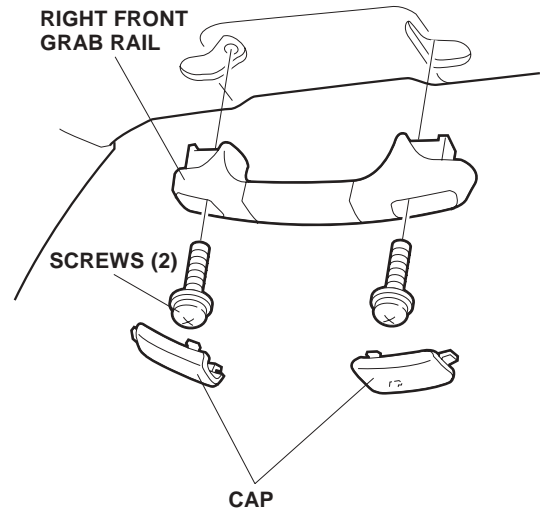

30. Remove the door weatherstrip from the opening edge of the right front door in the area shown, then remove the right front pillar trim (two clips).

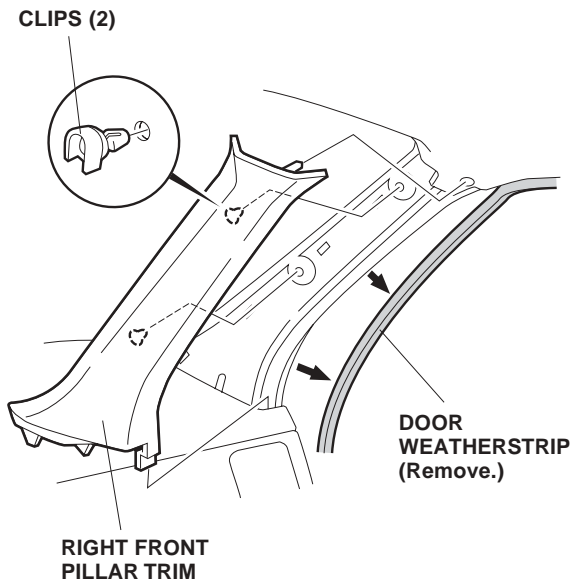

31. Remove the cap from the left sun visor (four retaining tabs).

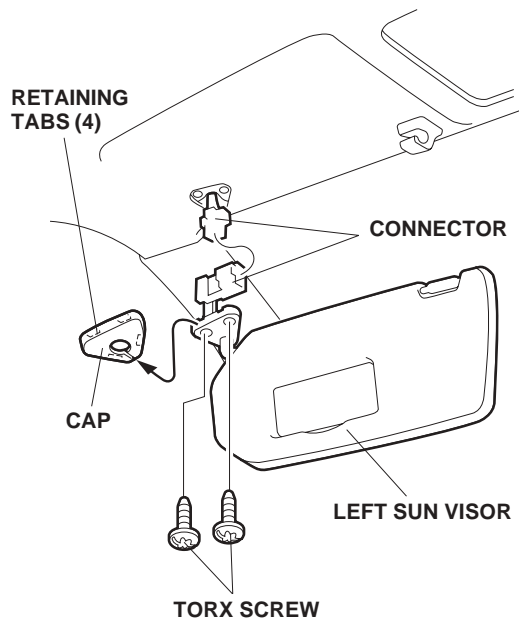

32. Remove the left sun visor (two Torx screws and unplug the connector).

33. Remove the two caps from the left front grab rail and remove the grab rail (two screws).

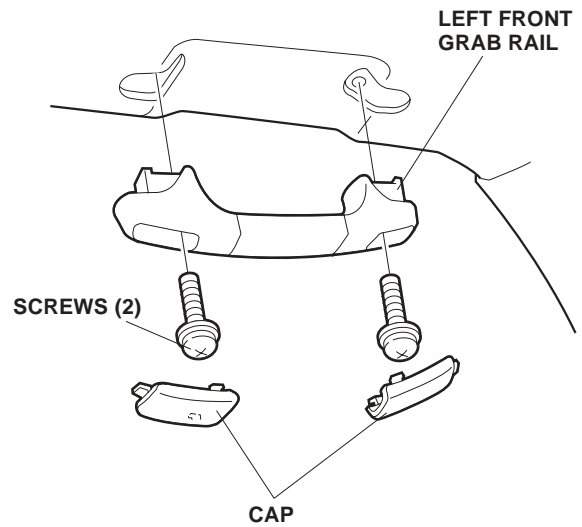

34. Remove the door weatherstrip from the opening edge of the left front door in the area shown, then remove the left front pillar trim (two clips).

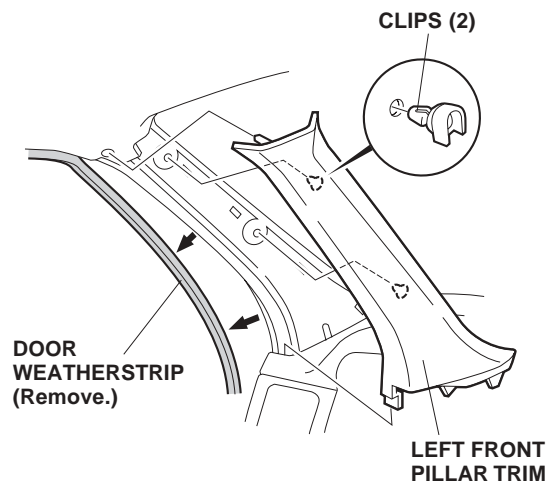

Routing the *i*-VES Harness and Installing the Monitor Console

35. Route the *i*-VES harness:

- Route the 20-pin connectors up from the center panel opening to the audio unit opening.
- Route the 16-pin connector (black) from the center panel opening through the glove box opening to the right kick panel opening.
- Route the 8-pin connector from the center panel opening to the center console lower cover opening.

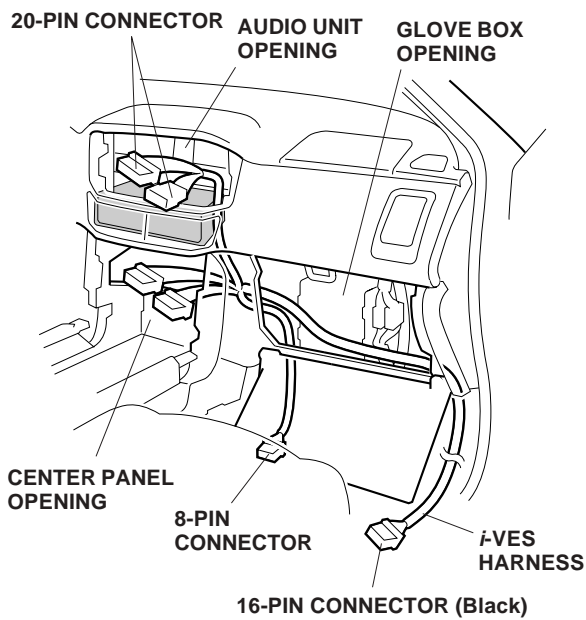

36. Route the *i*-VES harness 16-pin connector (black) along the right front door step toward the right center pillar.

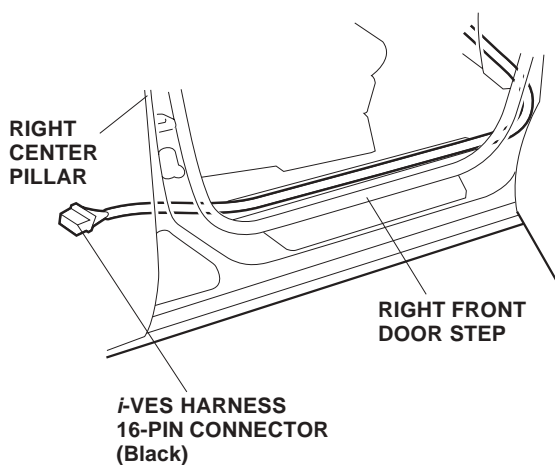

37. Route the *i*-VES harness 16-pin connector up the right center pillar.

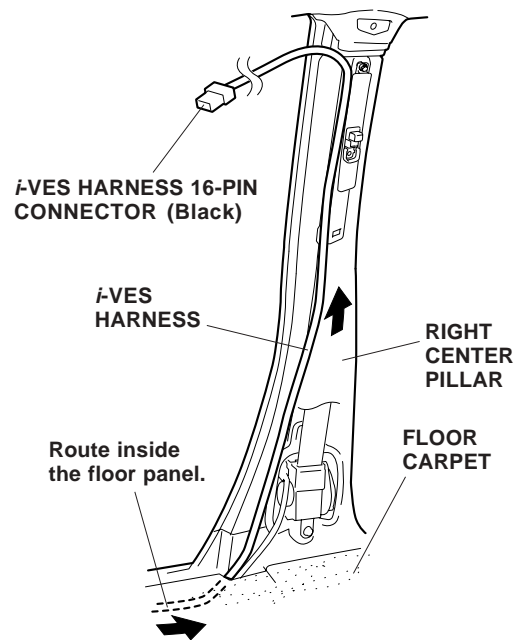

38. Remove the sun visor holders by rotating them clockwise.

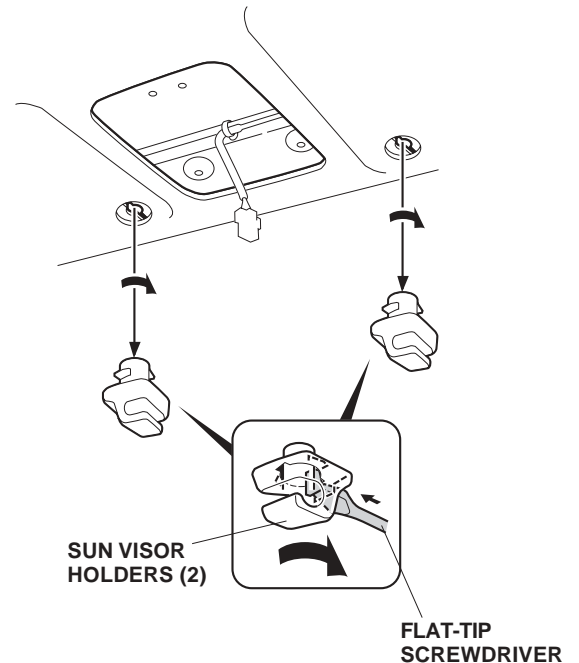

39. Wrap the piece of wire around the *i*-VES harness 16-pin connector. Using electrical tape, secure the wire to the 16-pin connector.

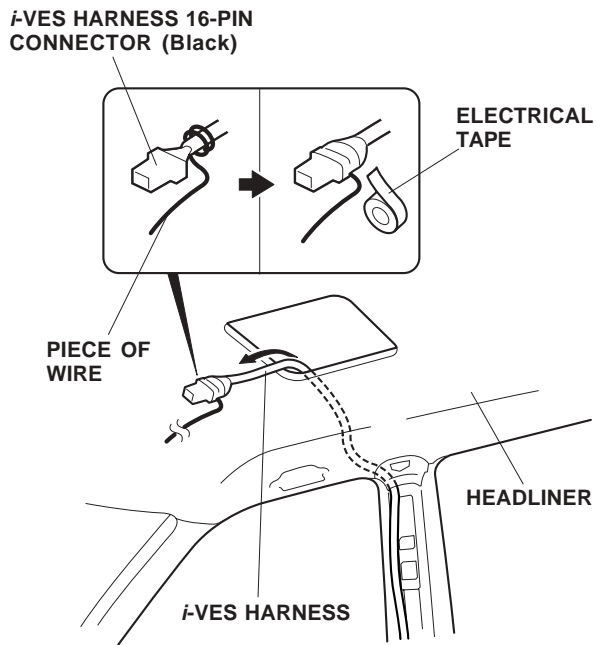

40. Pull the 16-pin connector behind the headliner and out through the cutout. Remove the tape and wire.
41. Slide the monitor bracket into the headliner as shown.

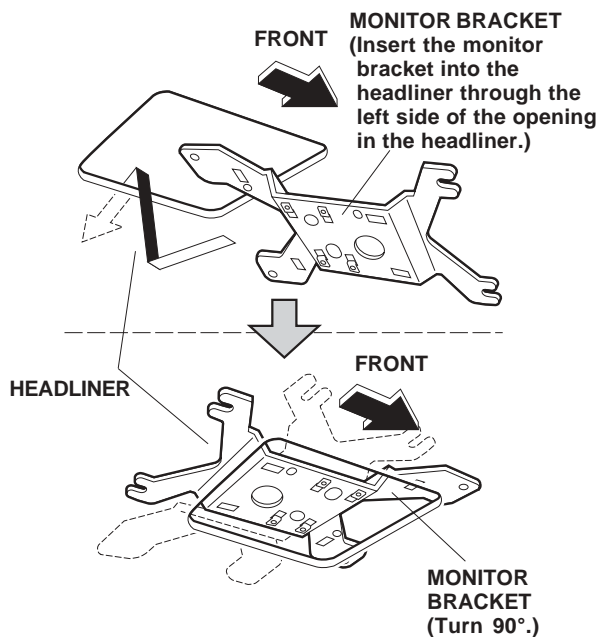

42. Install the monitor bracket to the roof panel with the four 6 x 12 mm washer-bolts.

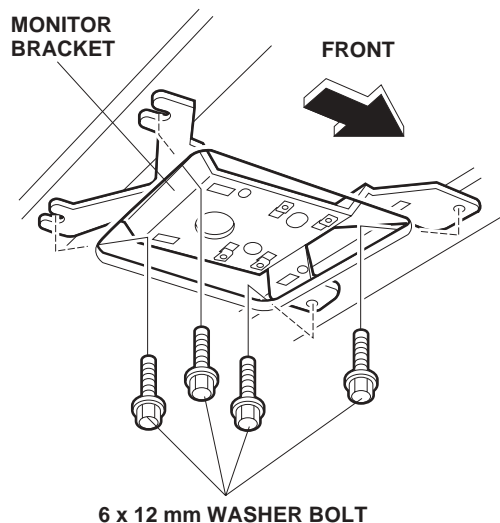

43. Install the monitor trim ring to the monitor bracket (four clips).
44. Connect the *i*-VES harness 16-pin connector (black) to the monitor console, then secure the harness clip of the *i*-VES harness to the rib of the monitor console as shown.

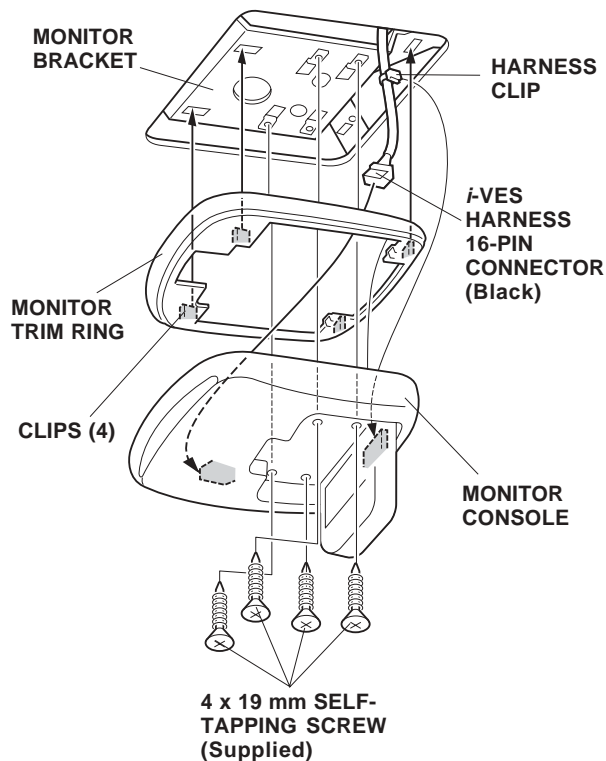

45. Secure the monitor console to the monitor bracket with the four 4 x 19 mm self-tapping screws supplied.

46. Using a tape measure and felt-tip pen, measure and mark the headliner as shown. Using the utility knife, cut out the marked area as shown.

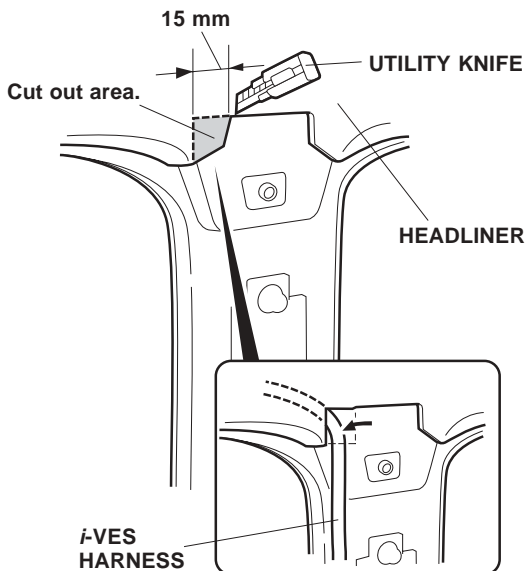

47. Move the *i*-VES harness to the end of the cut out area you just made as shown.
48. Secure the *i*-VES harness to the front seat belt shoulder anchor adjuster with two wire ties in the areas shown. Check that the harness and wire ties do not interfere with the operation of the seat shoulder anchor adjuster.

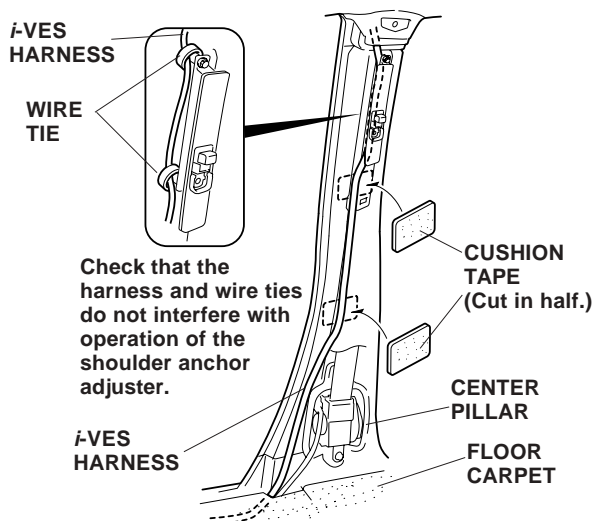

49. Using isopropyl alcohol on a shop towel, thoroughly clean the areas where the cushion tapes will attach. Using scissors, cut the cushion tape in half. Secure the *i*-VES harness to the right center pillar with two pieces of cushion tape in the areas shown.

50. Turn over the floor carpet. Using isopropyl alcohol on a shop towel, thoroughly clean the areas where the cushion tapes will attach. Secure the *i*-VES harness to the right front door step with two pieces of cushion tape in the areas shown.

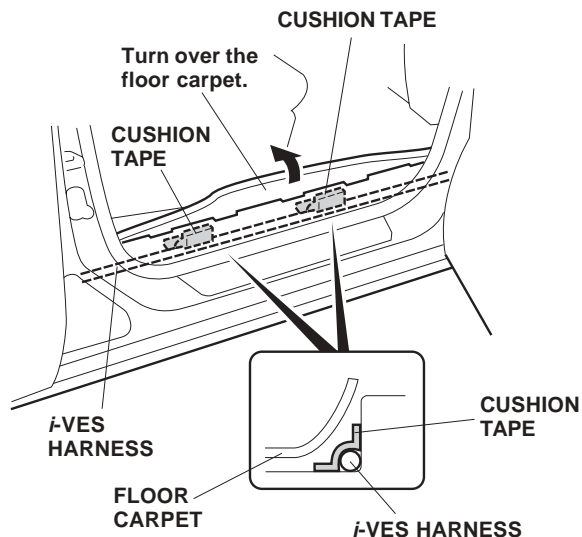

51. Near the fuse box, secure the *i*-VES harness to the vehicle harness with three wire ties. Do not secure the *i*-VES harness to the yellow SRS harness.

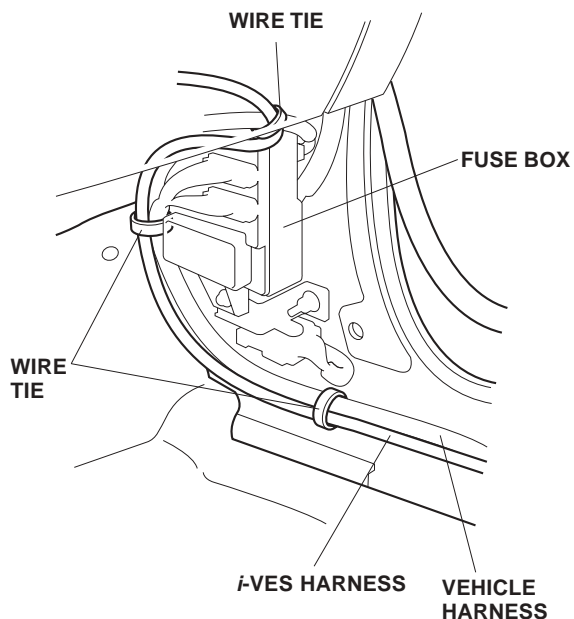

52. In the glove box opening, secure the *i*-VES harness to the vehicle panel with two wire ties.

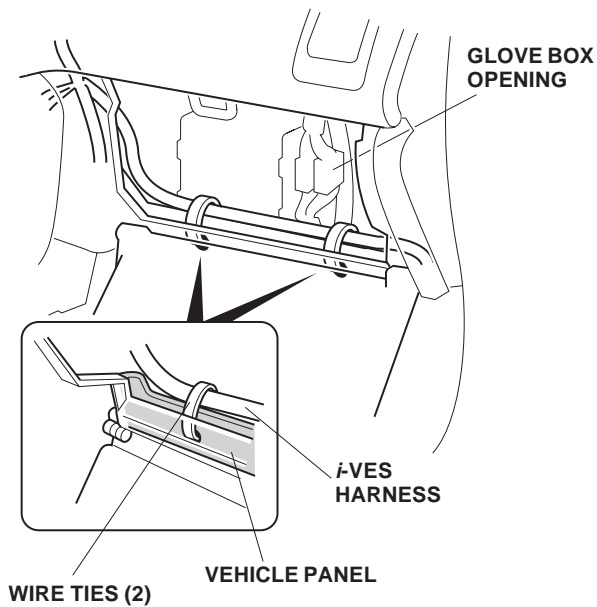

53. In the center console lower cover opening, plug the *i*-VES harness 8-pin connector into the FM modulator.

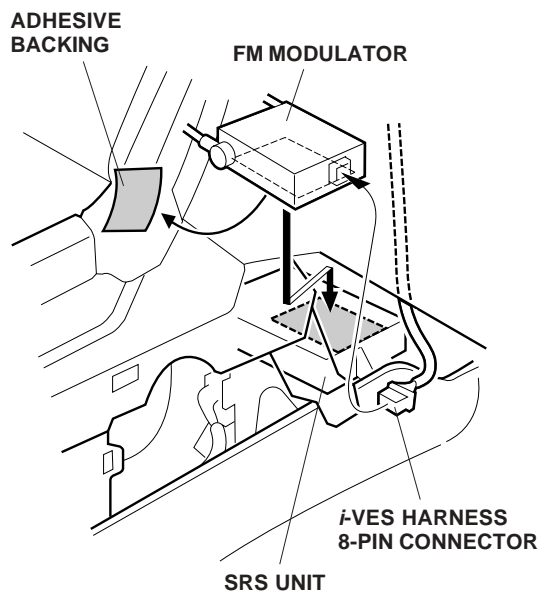

54. Using isopropyl alcohol on a shop towel, thoroughly clean the area where the FM modulator cushion tape will attach. Remove the adhesive backing from the cushion tape, and attach the FM modulator to the SRS unit.

55. Unplug the vehicle antenna leads, and plug in the FM modulator antenna leads in between the vehicle antenna leads.

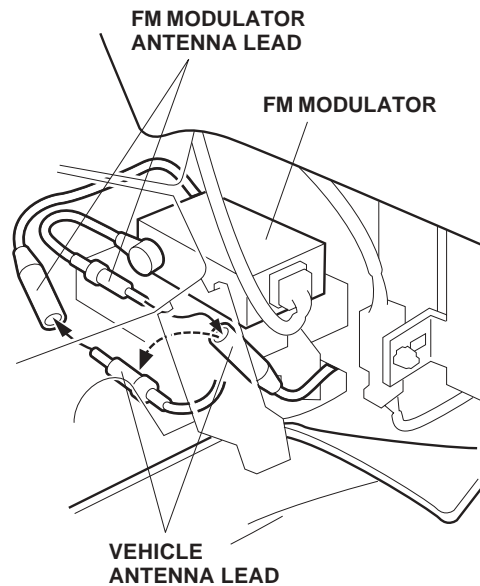

56. Connect the *i*-VES harness 20-pin connector to the vehicle 20-pin connector; secure them with one wire tie.

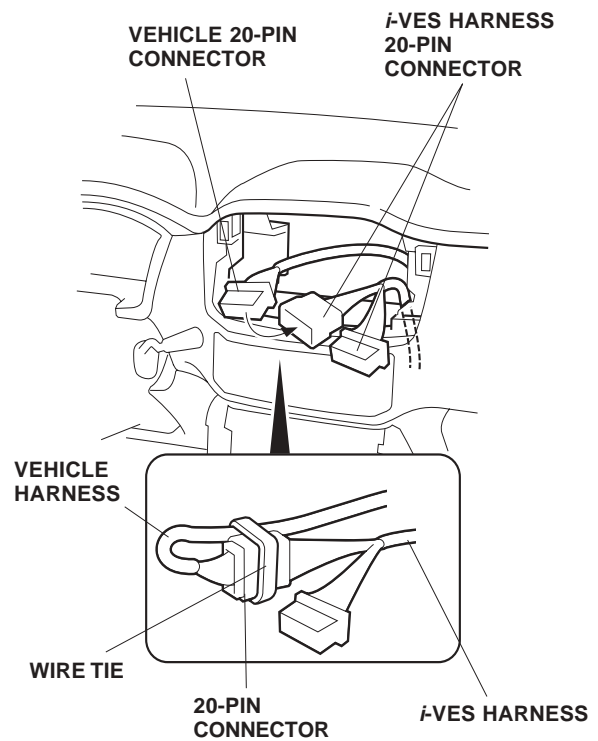

57. Plug the *i*-VES harness 20-pin connector and vehicle antenna lead into the rear of the audio unit. Reinstall the audio unit with the four screws removed in step 11.

With Pocket:

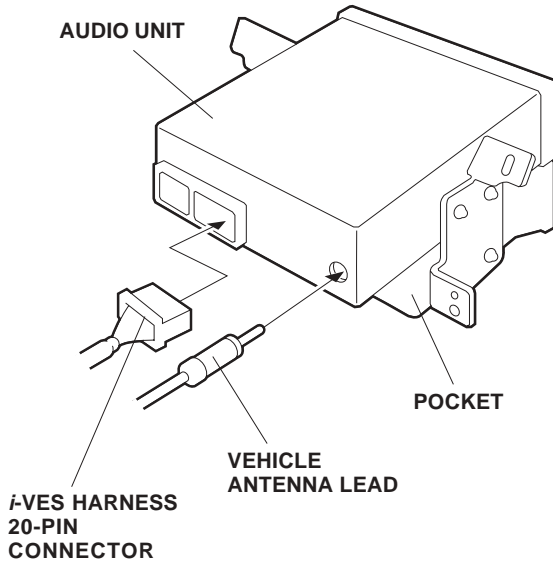

With Cassette Player:

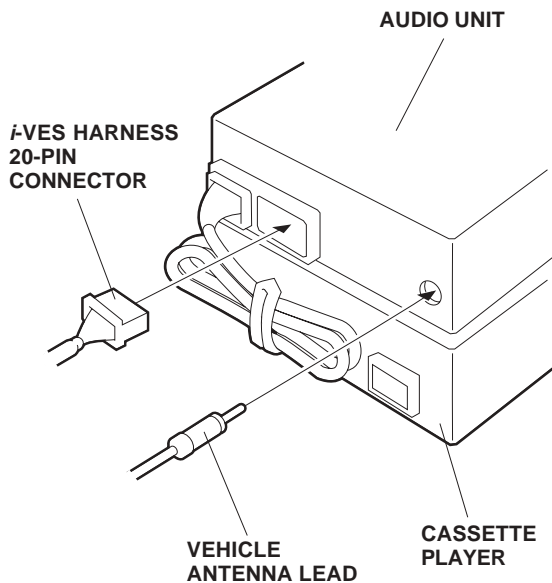

58. Remove the left and right vehicle brackets (six self-tapping screws), separate the heater control unit from the pocket. Set the pocket aside it will not be reused.

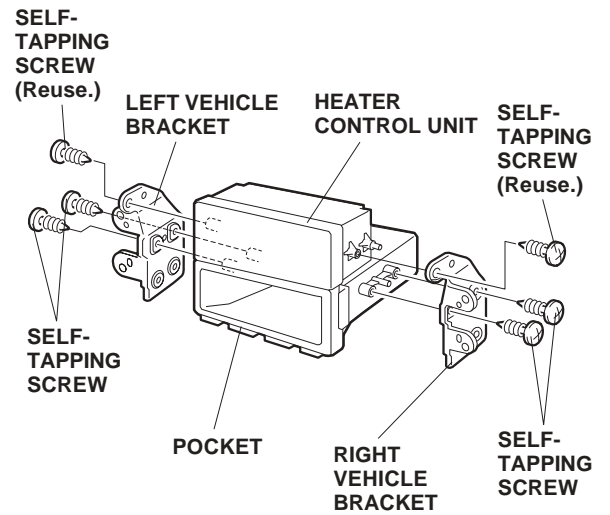

59. Install the DIN bezel to the DVD player. Set the heater control unit on the DVD player, attach the left and right vehicle brackets using the two self-tapping screws removed in step 58 and four 5 x 12 mm washer-screws included in the kit.

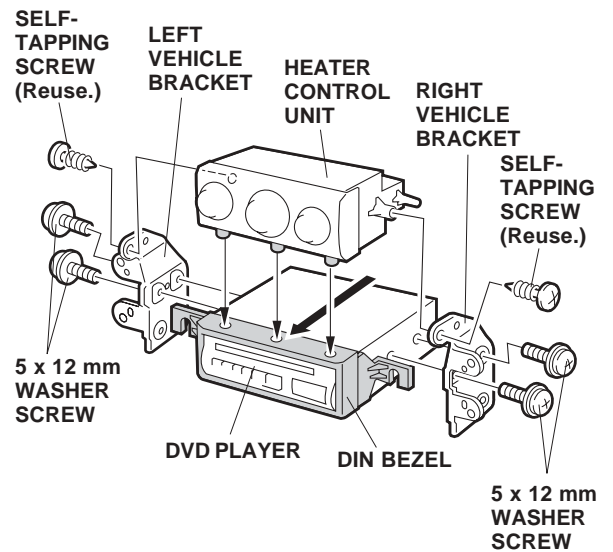

60. Plug the *i*-VES harness 16-pin and 20-pin connectors into the rear of the DVD player.

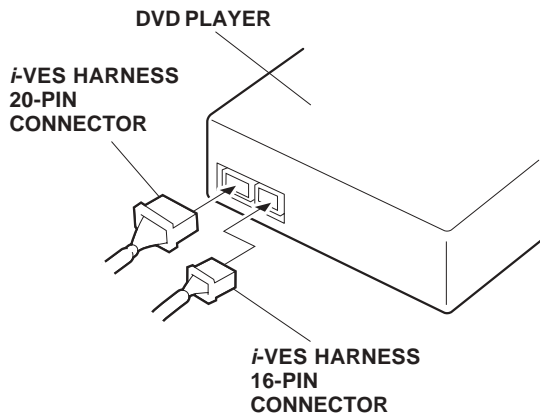

61. Remove the two washer-screws from the dashboard. Slide the heater control unit and DVD player into the center panel opening, and reinstall the four screws.
62. Install the DIN bezel to dashboard with the two washer-screws removed in step 61.

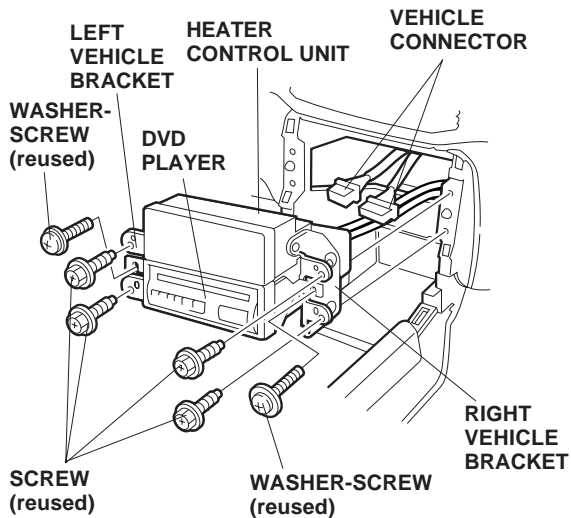

63. Reinstall all removed parts.
- Torque the seat bolts to 41 to 53 N·m (30.3 to 39 ft·lb)
 - Torque the seat belt anchor bolts to 29.4 to 34.3 N·m (21.6 to 25.2 ft·lb)
64. Reconnect the negative cable to the battery.
65. Enter the customer's radio anti-theft code, and reset the radio station presets.
66. Set the clock.
67. Check the operation of the in-vehicle entertainment system according to Owner's Manual supplied with the unit.
68. Put the in-vehicle entertainment system Owner's Manual in the glove box.
- NOTE:** Whenever the battery is disconnected, the driver's window AUTO function is disabled.
69. Start the engine. Push down on the driver's window switch until the window is fully open.
70. Pull up on the driver's window switch to close the window completely, then hold the switch for 2 seconds.
71. Test the AUTO window function.