

Accessory	Application	Publications No.
TRUNK SPOILER	TL	BII 25349
		Issue Date
		OCT 2003

PARTS LIST

Trunk spoiler

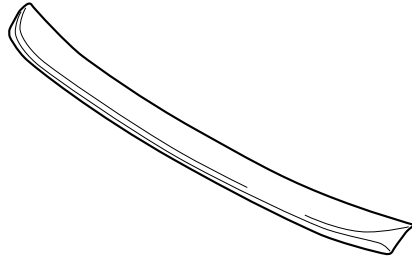

Left trunk spring
(marked yellow)

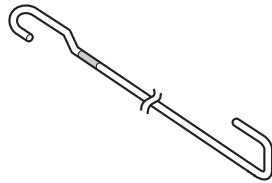

Template



2 Washer nuts



TOOLS AND SUPPLIES REQUIRED

- Clip remover
- Eye protection (face shield, safety goggles, etc.)
- Drill
- 3 mm and 8 mm Drill bits
- Drill stop
- File
- Center punch
- Touch-up paint
- Ratchet
- 10 mm Socket
- Torque wrench
- Gloves
- Trunk spring installer/remover:
 T/N 08M10-SM4-100
- Masking tape
- Felt-tip pen
- Shop towel
- Isopropyl alcohol
- Tape measure
- Utility knife

INSTALLATION

Customer Information: The information in this installation instruction is intended for use only by skilled technicians who have the proper tools, equipment, and training to correctly and safely add equipment to your vehicle. These procedures should not be attempted by “do-it-yourselfers.”

NOTE:

- Be careful not to damage the body paint finish.
- This trunk spoiler kit should be installed only if the ambient air temperature is 60°F (15°C) or above.
- Wash and wax the area to be covered with a high-quality paste wax.

Installing the Trunk Spoiler

1. Open the trunk lid. Remove the right and left bump stops, then remove the trunk lid trim (eleven clips and one self-tapping screw).

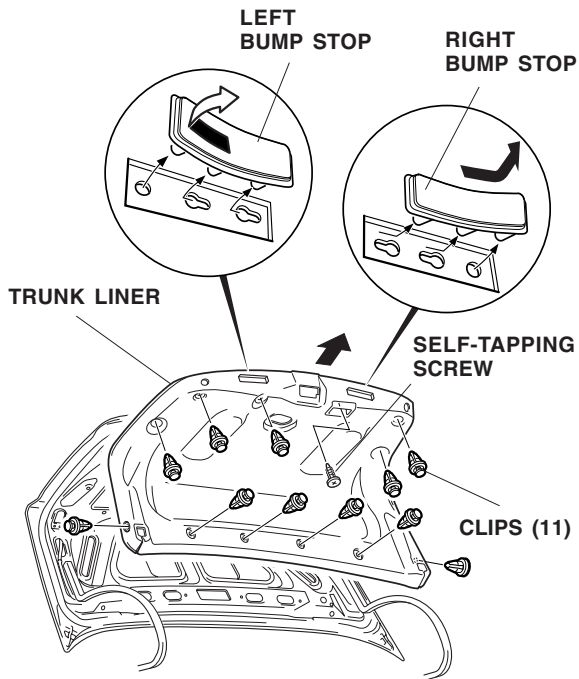

3. Close the trunk lid. Place the template at the left edge of the trunk lid and mark the edge of the trunk lid at the mark on the template. Mark the right side the same way. Using a tape measure, measure across the trunk lid at the marks, divide the measurement in half to locate the center of the trunk lid.

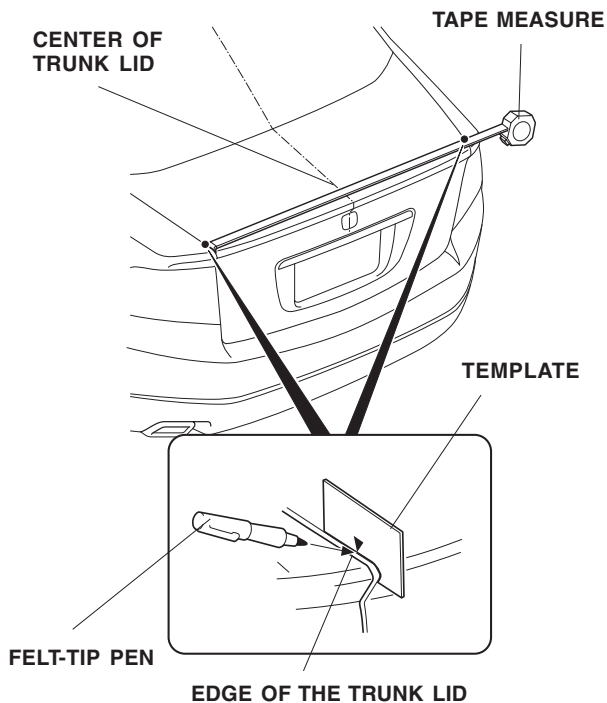

4. Measure 278 mm (10.9 in.) outboard from the center and mark the trunk lid on each side. Position the template on the trunk lid. Using a felt-tip pen, mark the trunk lid as indicated on the template. Do this procedure on each side of the trunk lid.

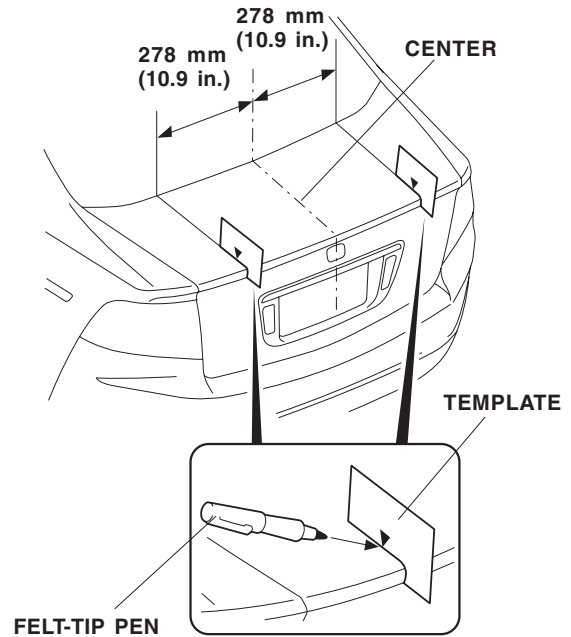

5. Lightly center-punch the marks. While wearing eye protection, drill two 8 mm holes through the marks you made.
 - Using a drill stop on the end of each bit, first drill with a 3 mm drill bit, and finish with an 8 mm drill bit.
 - Take care not to damage the wire harnesses in the left side of the body when drilling the holes.
 - After drilling, remove any burrs from the edges of the holes with a file and apply touch-up paint on both sides of the holes. Allow the touch-up paint to dry before you proceed to the next step.

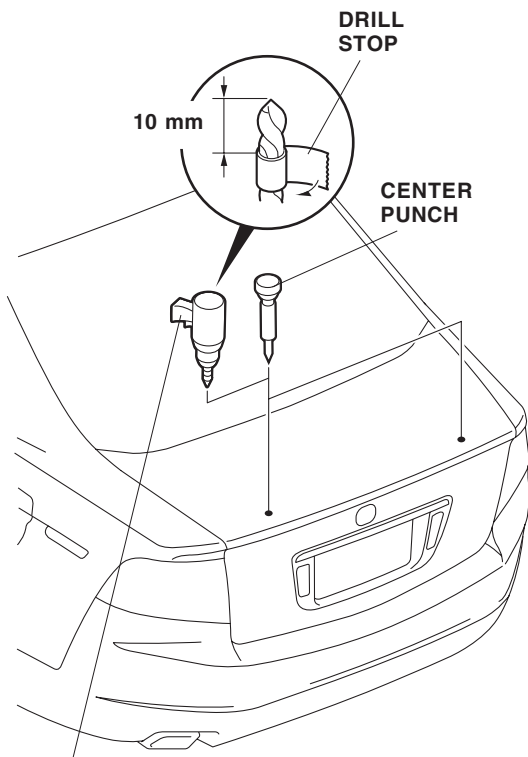

DRILL
First drill with a 3 mm drill bit, and finish with an 8 mm drill bit.

6. On the inside of the trunk spoiler, attach a strip of masking tape to the ends of the adhesive backings, and remove 1-1/2 to 2 inches of the adhesive backing. Fold the ends back, and tape them to the front of the spoiler.

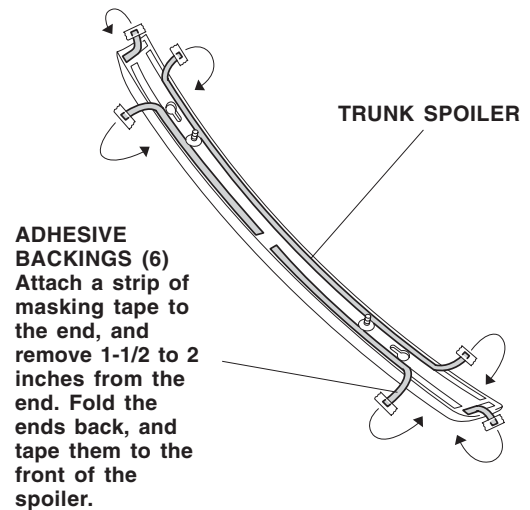

7. Using isopropyl alcohol on a shop towel, thoroughly clean the area where the trunk spoiler will attach.
8. Remove the clip that secures the vehicle harness to the trunk lid.

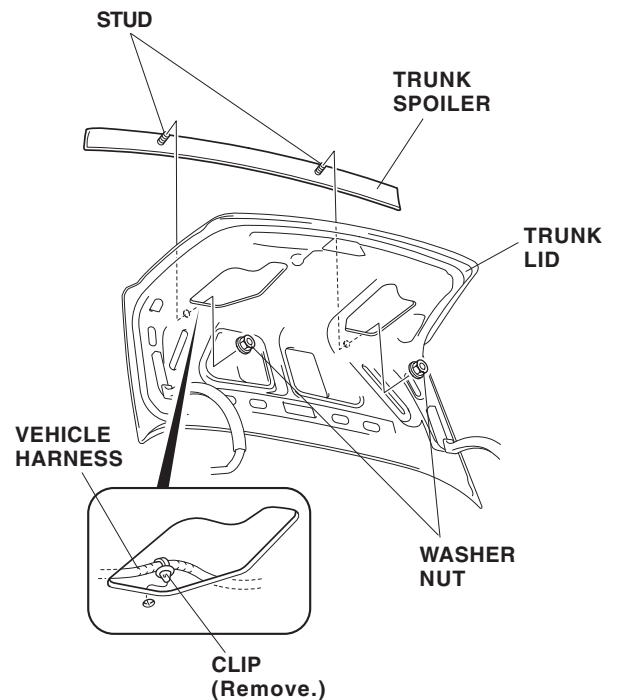

9. Fit the spoiler into position on the trunk lid by inserting the two studs into the holes in the trunk lid. With an assistant holding the trunk lid open, install a flange nut on the end of each stud. Install the two washer-bolts, but do not tighten them yet.

- When the trunk spoiler is aligned properly with the trunk lid, carefully remove the adhesive backing on each side. Hold the spoiler firmly against the trunk lid with the palm of your hand.

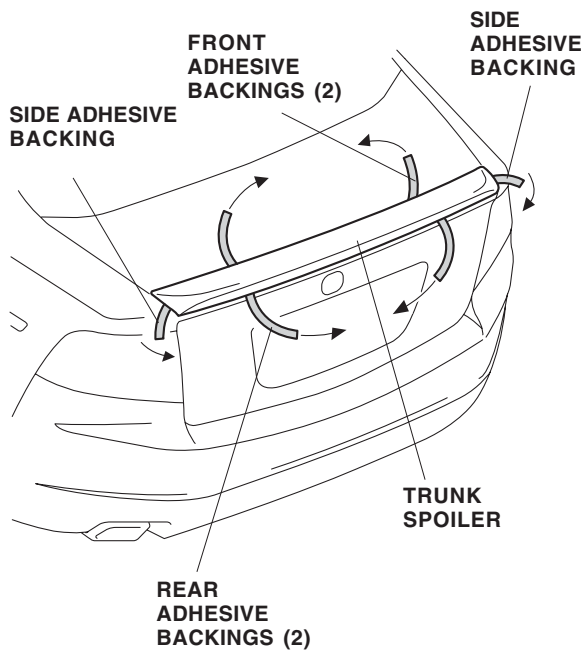

- Open the trunk lid and torque the two flange nuts and two washer-bolts to 10 N·m (7 lb-ft).
- Reattach the vehicle harness clip removed in step 8.

Installing the Trunk Spring

- Remove one anchor-bolt and fold the right trunk side panel out of the way.

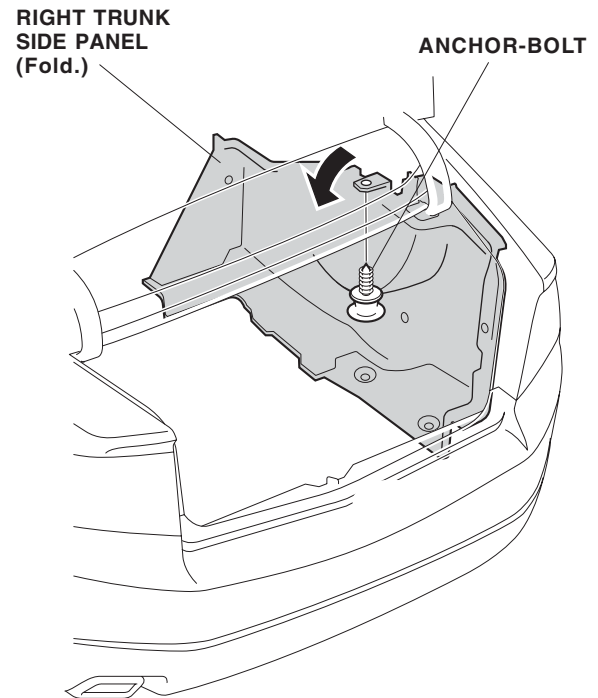

- Remove four clips and turn down the rear shelf under cover. Push the center of the clips to remove them.

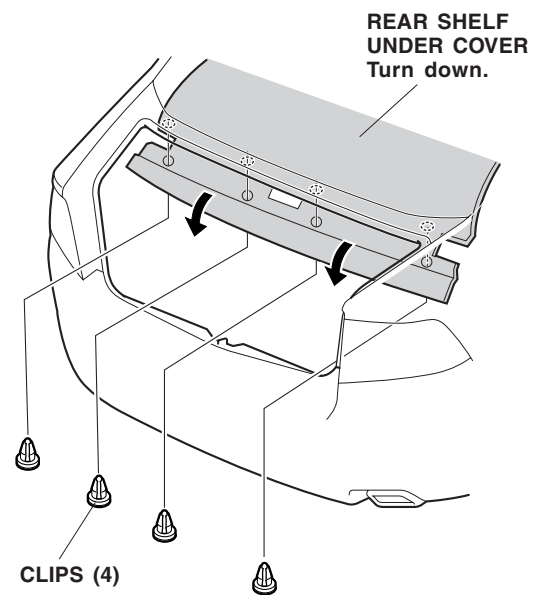

15. Open the trunk lid, and remove the center clip from the trunk springs.

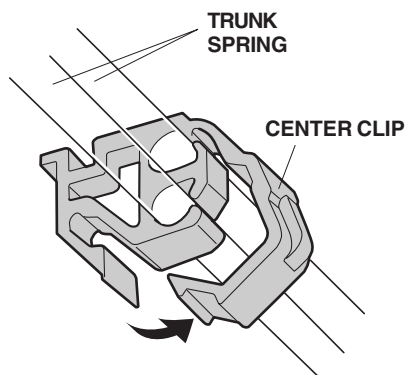

16. With an assistant holding the trunk lid open, remove the old left trunk springs from the trunk hinge arms using the special tool. Wear gloves to protect your hands, and pull the special tool slowly and carefully toward you.

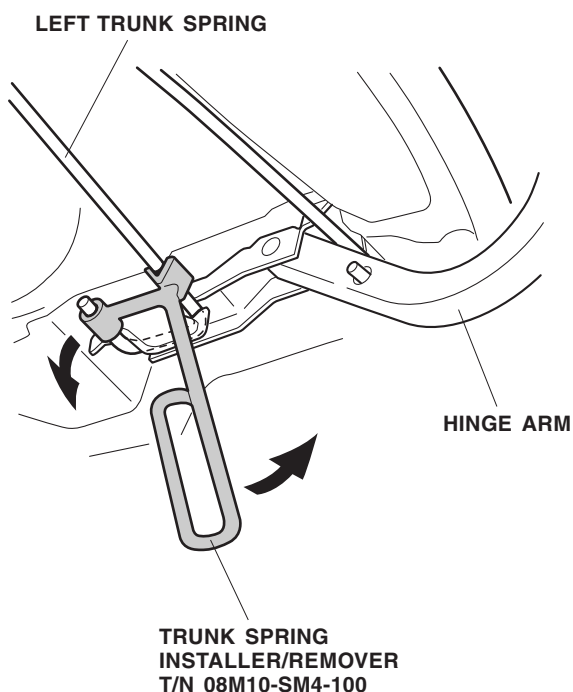

17. Using the special tool, install the left trunk spring in the reverse order of removal:

- Install the yellow-marked spring in the slot in the left (driver's) side trunk hinge arm and to the hinge bracket on the right (passenger's) side of the vehicle.
- Wearing gloves, rotate the tool as you pull it toward you.
- Set the springs in the first notch (original position) of the hinge brackets.

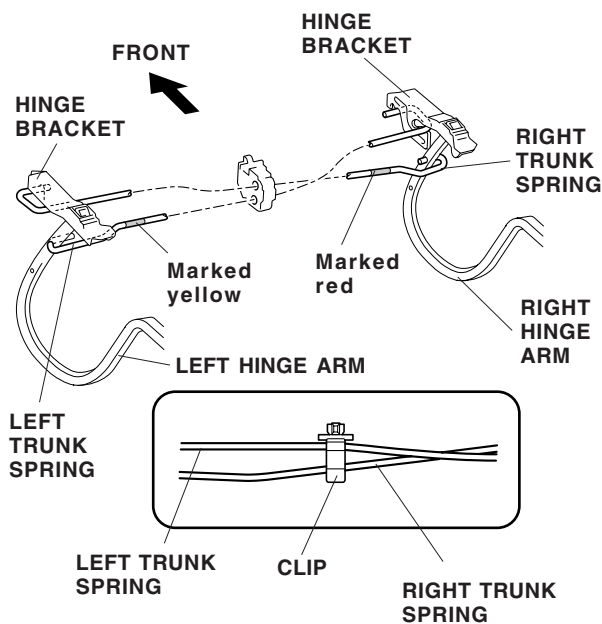

18. Reinstall the center clip on the trunk springs.
19. Reinstall all removed parts. Check that the clips are installed securely.
20. Open the trunk lid, and make sure the trunk lid stays open on its own. If necessary, adjust the trunk springs to the second position.

USE AND CARE

- Handle the spoiler with care. It is not designed to absorb impact.
- Do not open or close the trunk lid using the spoiler.
- Check the spoiler mounting nuts periodically, and retighten them if necessary.