



INSTALLATION INSTRUCTIONS

Accessory

REAR WING SPOILER

Application

TL

Publications No.

BII 25343

Issue Date

OCT 2003

PARTS LIST

Rear wing spoiler

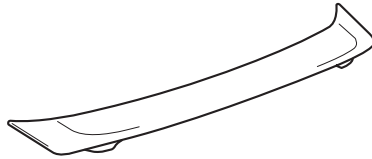

Left bracket



Right bracket

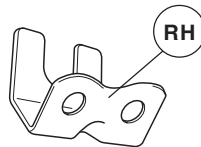

Left trunk spring
(marked yellow)

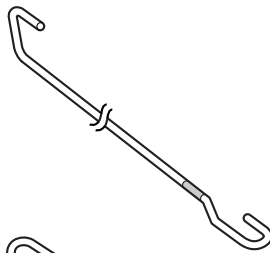

Right trunk spring
(marked red)

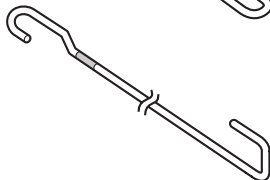

4 Flange bolts



4 Flange nuts



Template

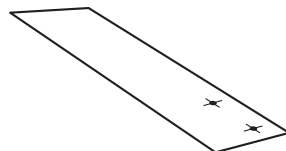

TOOLS AND SUPPLIES REQUIRED

Trunk spring Installer/Remover T/N 08M10-SM4-100

12 mm Combination wrench

10 mm Socket

Torque wrench

Ratchet

Drill

3 mm and 8 mm Drill bits

Center punch

Round file

Felt-tip pen

Touch-up paint

Drill stop

Isopropyl alcohol

Shop towel

INSTALLATION

Customer Information: The information in this installation instruction is intended for use only by skilled technicians who have the proper tools, equipment, and training to correctly and safely add equipment to your vehicle. These procedures should not be attempted by "do-it-yourselfers."

NOTE:

- Be careful not to damage the body paint finish.
- This trunk spoiler kit should be installed only if the ambient air temperature is 60°F (15°C) or above.
- Wash and wax the area to be covered with a high-quality paste wax.

Installing the Trunk Spoiler

1. Open the trunk lid. Remove the right and left bump stops, then remove the trunk lid trim (eleven clips and one self-tapping screw).

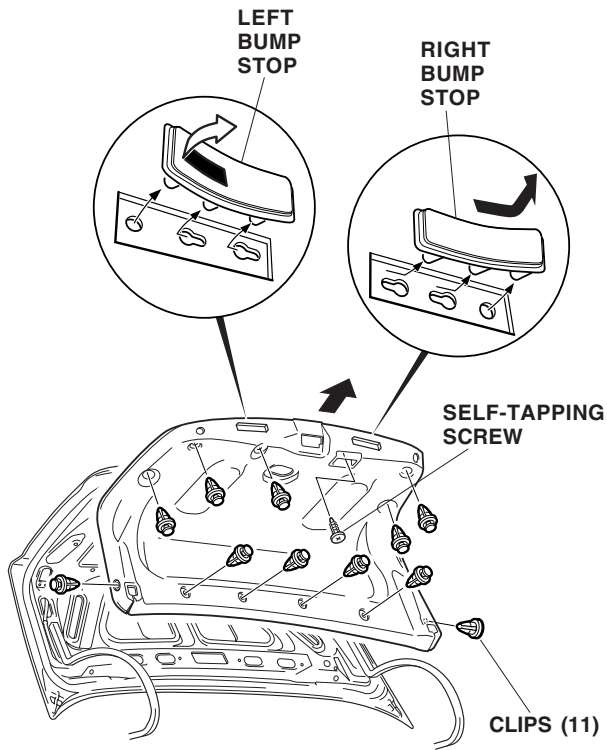

2. Close the trunk lid. Place the template on the left side of the trunk lid and align its outer edge with the end of the trunk lid. Using a felt-tip pen, mark the trunk lid at each of the two holes in the template. Turn the template over and mark the right side the same way.

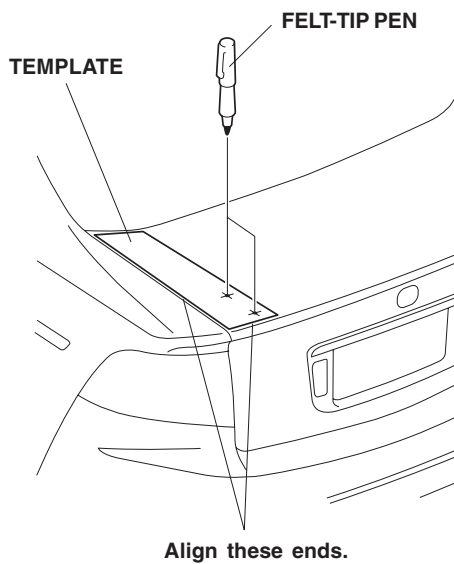

3. Lightly center-punch each mark, and drill an 8 mm hole through each center punched location:
 - Attach a drill stop to a 3 mm drill bit and an 8 mm drill bit.
 - First drill with a 3 mm drill bit, and finish with an 8 mm drill bit.
 - Remove all burrs, and apply touch-up paint to the holes.

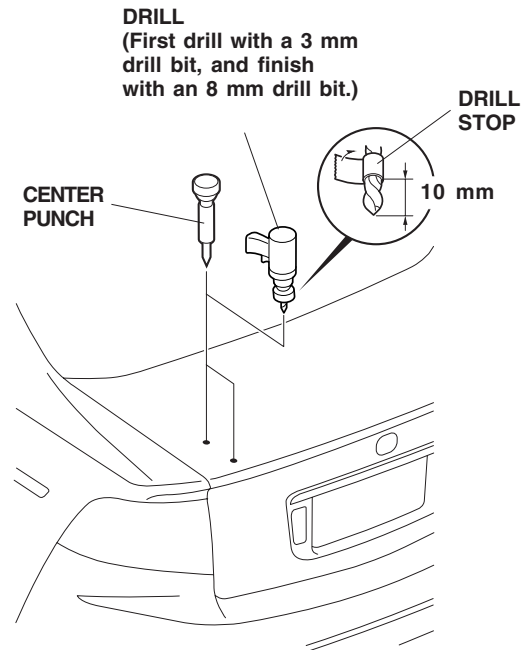

- Open the trunk lid. Fit the left bracket into the hole in the trunk lid, and install two flange bolts. Tighten the flange bolts securely. Repeat to install the right bracket.

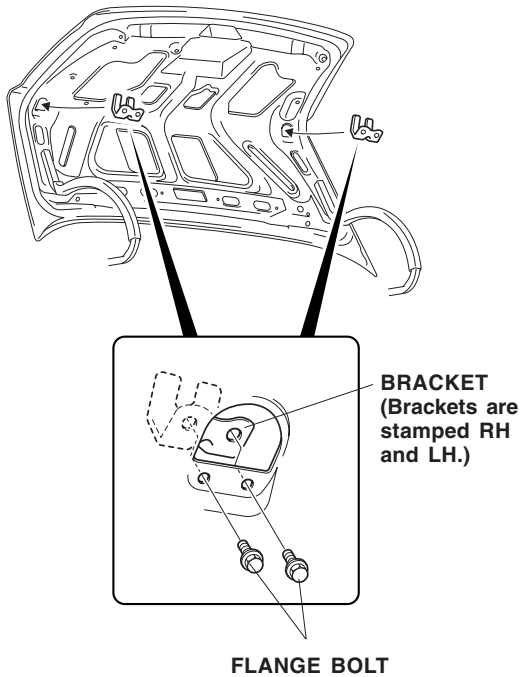

- Using isopropyl alcohol on a shop towel, clean the area to be covered with the adhesive tapes on the rear wing spoiler.

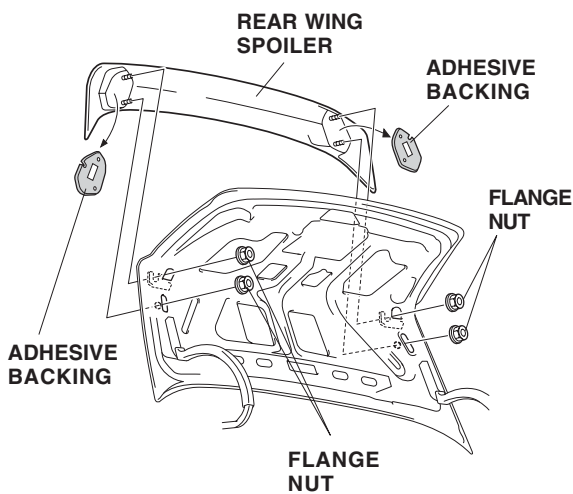

- Remove the adhesive backing from each end of the rear wing spoiler, then fit the rear wing spoiler on the trunk lid by inserting the two studs into the holes in the trunk lid. Install flange nuts on the ends of the studs, but do not tighten the flange nuts yet.
- Check that the rear wing spoiler is positioned equally on both sides, then torque the flange nuts to 9 N·m (7 lbf-ft).

Installing the Trunk Spring

- Remove one anchor-bolt and fold the left trunk side panel out of the way.

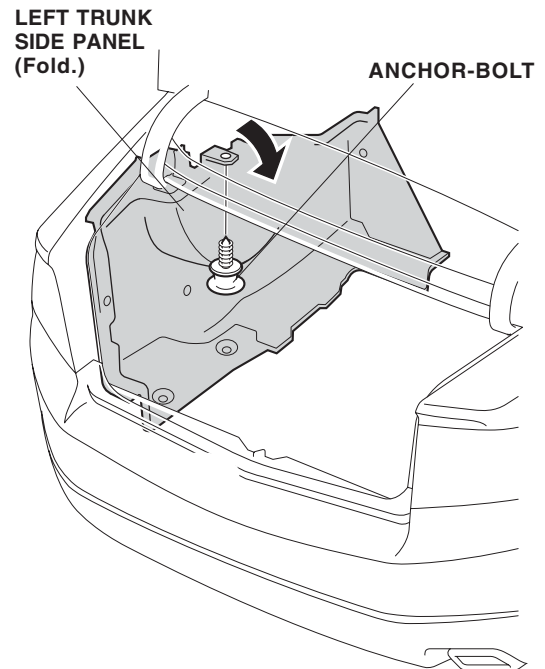

- Remove four clips and turn down the rear shelf under cover. Push the center of the clips to remove them.

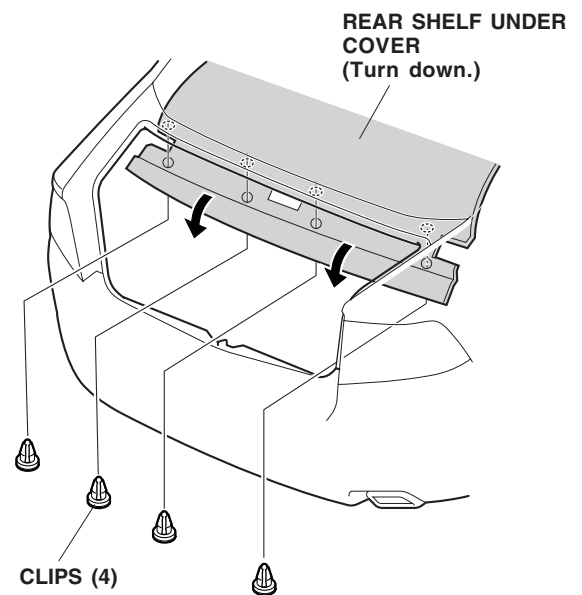

10. Remove the center clip from the trunk springs.

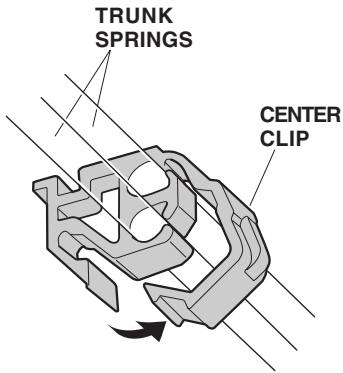

11. With an assistant holding the trunk lid open, remove the old trunk springs from the trunk hinge arms using the special tool. Wear heavy gloves to protect your hands, and pull the special tool slowly and carefully toward you.

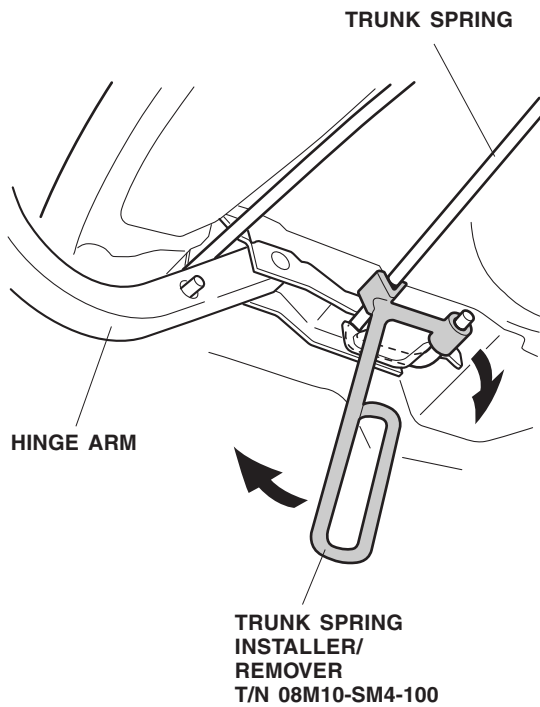

12. Using the special tool, install the right trunk spring and the left trunk spring in the reverse order of removal:

- Install the yellow-marked spring in the slot in the left (driver's) side trunk hinge arm and to the hinge bracket on the right (passenger's) side of the vehicle; install the red-marked spring in the slot in the right (passenger's) side trunk hinge arm and to the hinge bracket on the left (driver's) side of the vehicle.
- Wearing gloves, rotate the tool as you pull it toward you.
- Set the springs in the first notch (original position) of the hinge brackets.

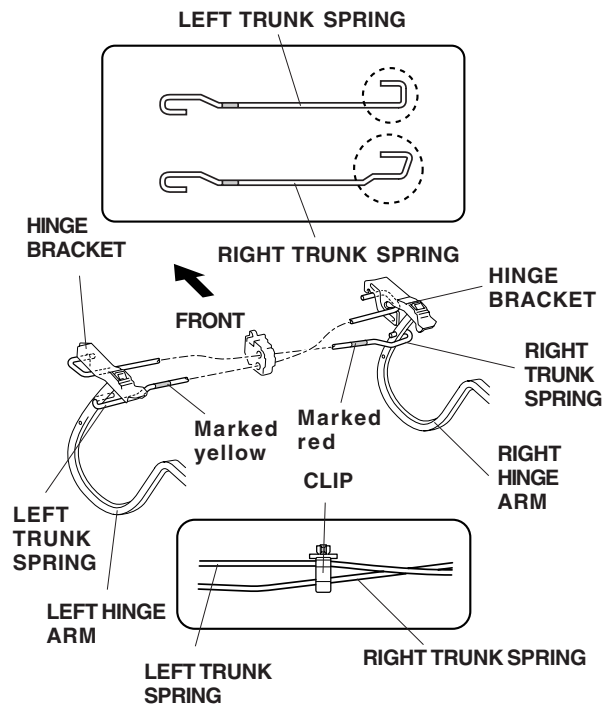

13. Reinstall the center clip on the trunk springs.

14. Reinstall all removed parts. Check that the clips are installed securely.

15. Open the trunk lid, and make sure the trunk lid stays open on its own. If necessary, adjust the trunk springs to the second position.

USE AND CARE

- Handle the spoiler with care. It is not designed to absorb shock or impact.
- Do not open or close the trunk lid by grasping the spoiler.
- Check the spoiler mounting nuts periodically, and retighten them as necessary.